

C. H. LANDENBERGER.
KNITTING-MACHINE.

No. 188,644.

Patented March 20, 1877.

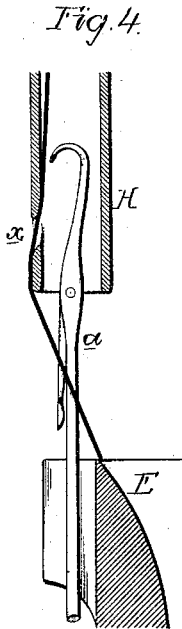
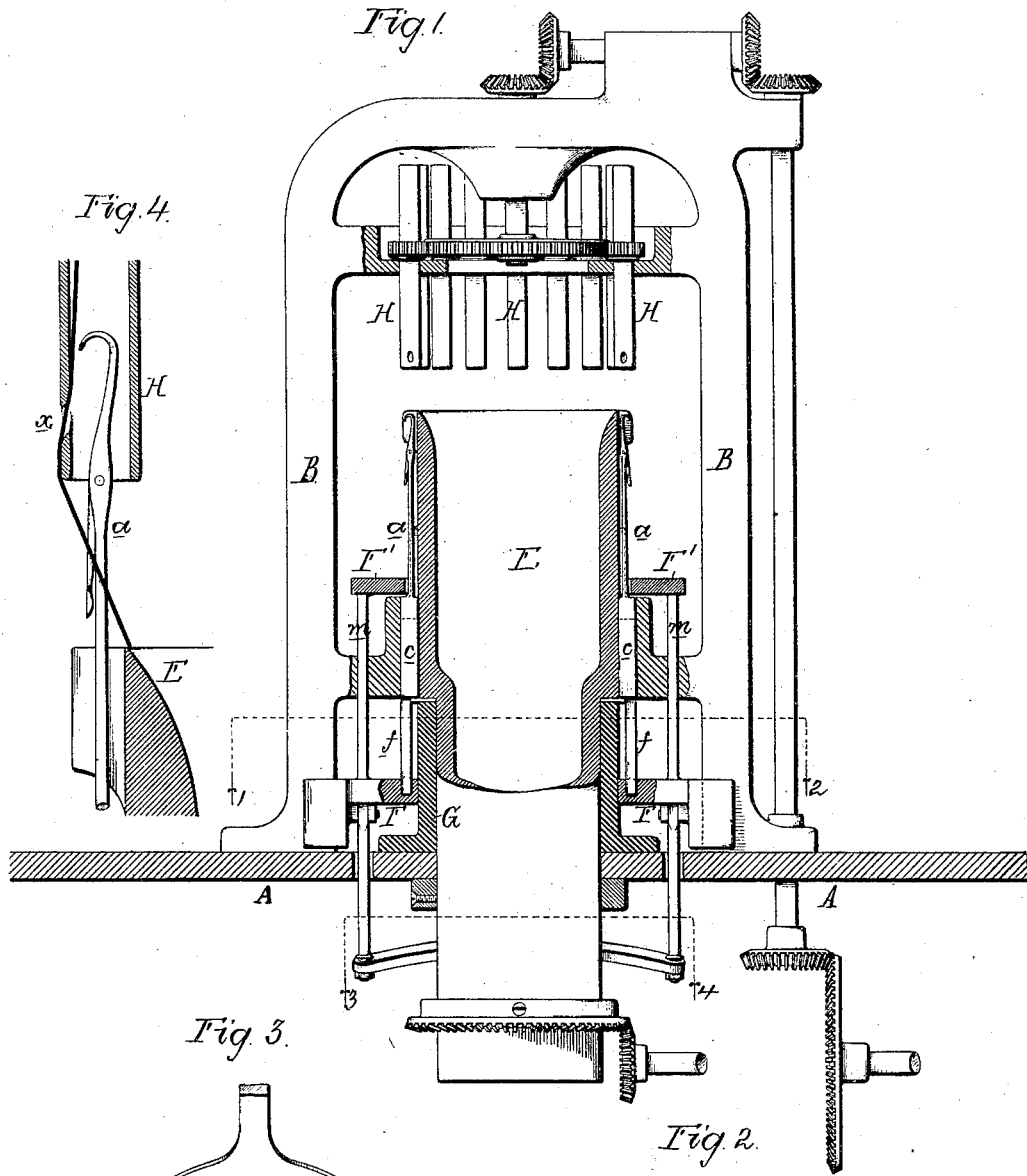

Fig. 3.

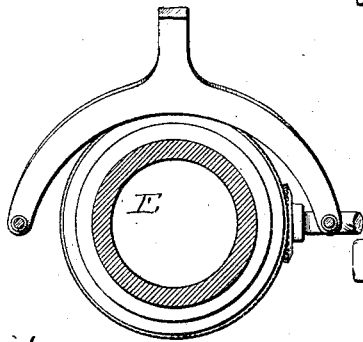
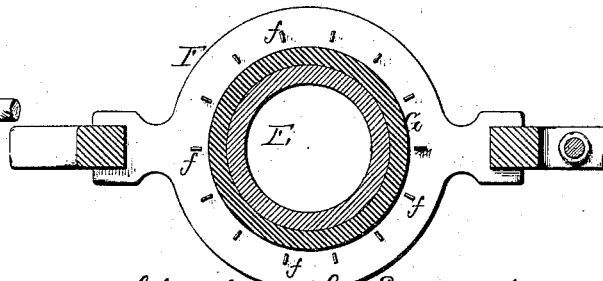

Fig. 2.



Witnesses
Hermann Hoessner
Harry Smith

Charles H. Landenberger
by his Attorneys
Houston and Co

C. H. LANDENBERGER.
KNITTING-MACHINE.

No. 188,644.

Patented March 20, 1877.

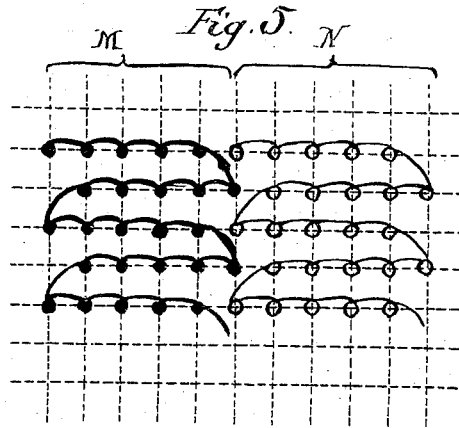
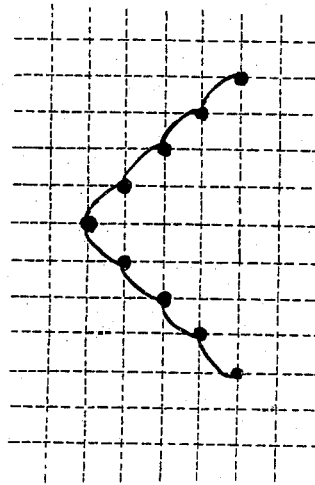

Fig. 6.



Witnesses

J. G. Shidmore
Ed. W. Nottingham

Charles H. Landenberger
by his Attorneys,
Howson and Son

UNITED STATES PATENT OFFICE.

CHARLES H. LANDENBERGER, OF PHILADELPHIA, PA., ASSIGNOR TO MARY A. LANDENBERGER, OF SAME PLACE.

IMPROVEMENT IN KNITTING-MACHINES.

Specification forming part of Letters Patent No. 183,644, dated March 20, 1877; application filed September 11, 1876.

To all whom it may concern :

Be it known that I, CHARLES H. LANDENBERGER, of Philadelphia, Pennsylvania, have invented certain Improvements in Knitting-Machines, of which the following is a specification :

My invention consists of a tubular fabric in the production of which the needles are caused to operate in sets, one thread being used in connection with each set of needles, the loops formed by each set forming a distinct fabric from, but united to, the fabrics made by the other sets, so that a knitted tube with patterns of a more than ordinary complex character may be produced.

The invention further consists of mechanism described hereafter.

In the accompanying drawing, Figure 1, Sheet 1, is a view, partly in section, of sufficient of a rotary knitting-machine to illustrate my invention; Fig. 2, a sectional plan on the line 1 2; Fig. 3, a sectional plan on the line 3 4; Fig. 4, a vertical section of part of the machine, drawn to an enlarged scale in order to illustrate its operation; and Fig. 5, Sheet 2, is a diagram showing the formation of the fabric.

A is the base; B, the frame of the machine, and E a hollow cylinder caused to revolve in suitable bearings, and carrying a series of guided latch-needles, *a*, as in ordinary circular-knitting machines. The rotation of the cylinder, however, is not continuous, as usual, but intermittent, each movement being such that the circles of needles will be moved to the extent of the distance between two adjoining needles.

The needles are provided with the usual bits *c*, which rest on pins *f*, attached to a ring, F, the latter surrounding the bearing G of the needle-cylinder E, and being guided by the frame of the machine or otherwise.

The needles are raised by the pins on this ring, to which an intermittent vertical movement is imparted by any suitable mechanism, and the needles may be depressed by a ring, F', connected by rods *m* to the ring F, the said ring F' acting upon the upper ends of the bits *c* of the needles.

A series of vertical thread-guides, H, which

I prefer to make tubular, as shown, are arranged in a circle, and have their bearings in a cross-bar of the frame, each tube having a pinion, and the pinions of the whole of the tubes being driven by a central wheel. There are as many tubes as there are pins *f* on the ring F, and each tube is directly above and in line with one of said pins.

The threads pass through the tubes H, and through eyes *x* at the lower ends of the same, as shown in Fig. 4, and thence to the fabric, which passes through the interior of the cylinder E.

The number of pins F and tubes H will depend upon the subdivision of the needles into sets, for it should be understood that the needles do not operate as in ordinary knitting-machines, but in sets, each set of needles operating on a separate thread, so as to produce separate fabrics looped together during the operation of knitting; hence, if there are in all one hundred needles, and they are intended to operate in sets of five each, there must be twenty equidistant pins *f*, and as many thread-guiding tubes H.

The operation of the machine is as follows: During the upward movement of the ring F its pins *f* raise every fifth needle of the whole series, or one needle of each set of twenty on the cylinder, the upper ends of the elevated needles passing into the tubes H, as shown in Fig. 4. The tubular thread-guides are now turned to the extent of one revolution, their threads being thereby wrapped round the needles, after which the latter descend and add their loops to those of the fabric, in the usual manner.

The cylinder is now turned to the extent of the distance between two adjoining needles, so that on the next upward movement of the ring F twenty needles, each needle adjoining that first operated on, will be raised, the threads wrapped round them, and on the descent of the needles their loops will be added to the fabric.

The fabrics produced by ordinary circular-knitting machines are restricted as regards the variety of their patterns, stripes produced by different-colored threads being the prevailing features of all the patterns.

By a machine constructed and operating in the manner described above, however, a circular fabric with more elaborate patterns may be produced.

For instance, we will suppose, as before, that there are one hundred needles, twenty tubes, and twenty pins *f*, and that the colors in the tubes alternate, one tube having a black thread, the next tube a white thread, and so on throughout. If, when the needle-cylinder has made five of the above-described intermittent movements in one direction, I cause it to make five similar movements in the opposite direction, and so on, the result will be a circular fabric with alternate black and white vertical stripes.

This will be best observed by reference to the diagram, Fig. 5, Sheet 2, where M and N represent two united strips of fabric, one strip being composed of a single dark thread, and another of strips of a light thread, the courses of loops being straight across the tube of fabric and parallel with each other. Now, the cylinder may be so operated that several courses of the loops of the light thread may form a continuation of the strip M, while loops of dark thread form continuations of the strip N.

If this change be continued the pattern will be of a plaid character, and it will be evident that patterns of a most intricate character can be produced by threads of many different colors, and by changes in the movement of the cylinder, the loops of the different strips made by different-colored threads being made to change places, as the taste of the operator may suggest.

This plan of forming a tube of knitted fabric of different colors and the fabric itself differ from ordinary modes and ordinary variegated tubes. For instance, Fig. 6 represents the course of the loops of the fabric made by the machine of Vickerstaff, patented March 20, 1847, the loops taking a diagonal course, and one thread being used for each needle, whereas according to my plan the courses of loops are straight across the tube of fabric, and but one thread is used for each set of needles.

I claim as my invention—

1. A tubular knitted fabric composed of a series of united strips, each strip being composed of one thread knitted into transverse courses of loops, and the last loop of a course in one strip being interlocked with the first loop of the next previous course of the adjacent strip, all as set forth.

2. The combination, in a circular-knitting machine, of an intermittently-rotating needle-carrying cylinder with thread-guides and devices, substantially as described, whereby the needles are caused to operate in sets, and whereby any thread-guide is caused to cooperate with any or all sets of needles, all as described.

In testimony whereof I have signed my name to this specification in the presence of two subscribing witnesses.

CHARLES H. LANDENBERGER.

Witnesses:

HERMANN MOESSNER,
HARRY SMITH.