

C. PARHAM.

LOCK AND CHAIN FASTENING COMBINED.

No. 188,664.

Patented March 20, 1877.

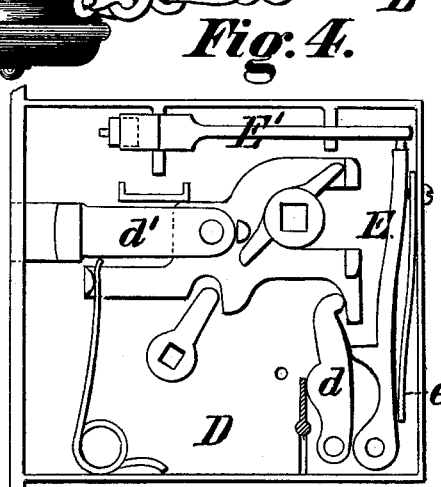
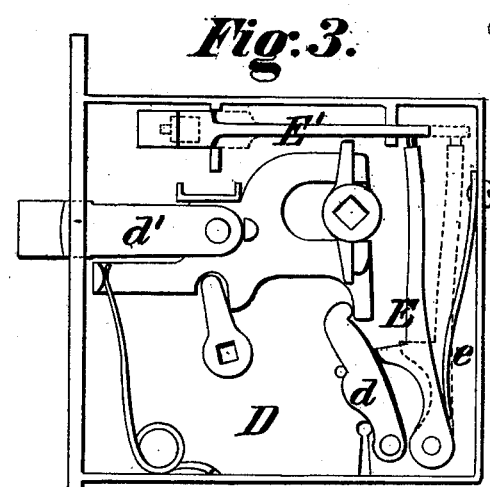
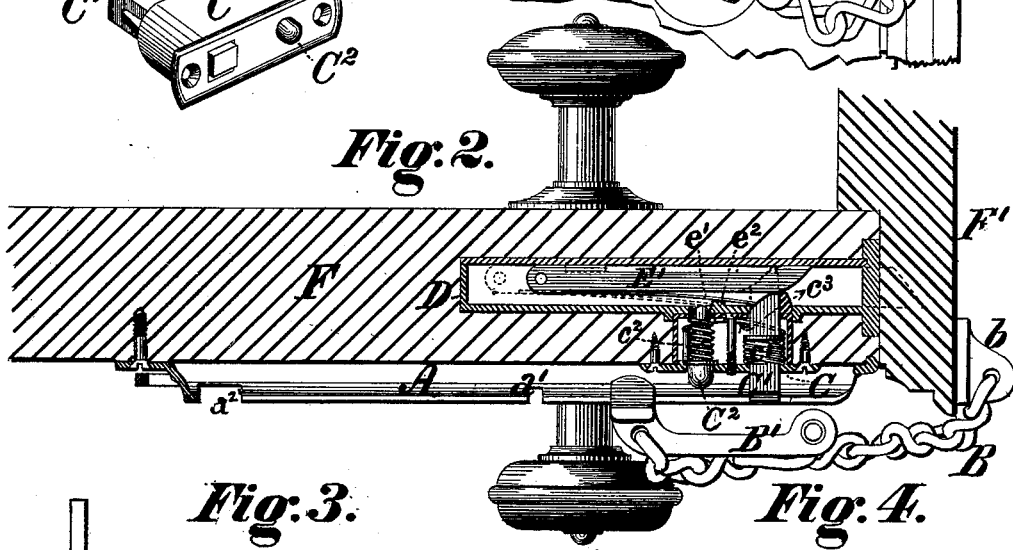
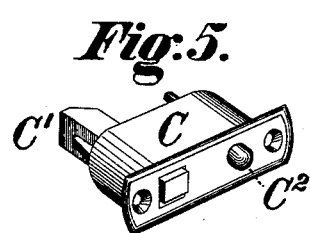
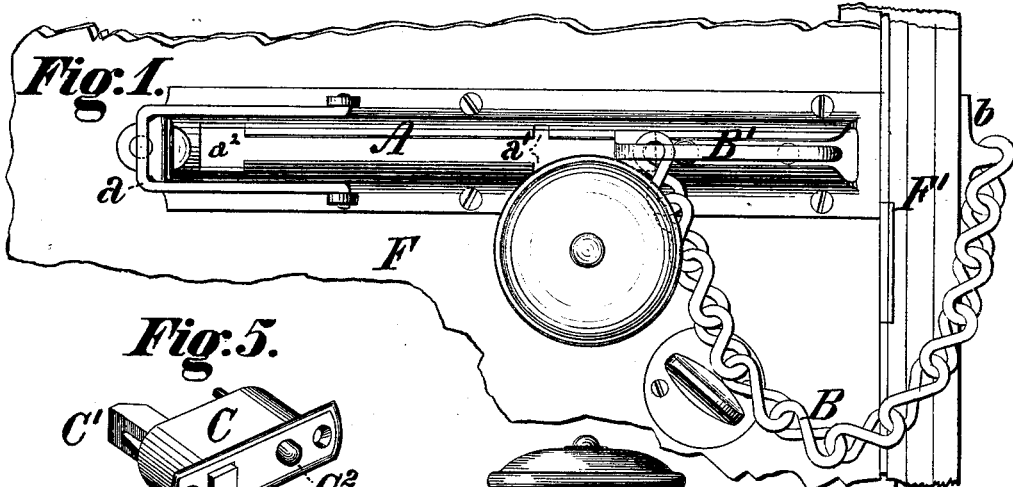

**Witnesses.**  
 S. L. Collier.  
 Chas. W. Schuellermann.

**Inventor.**  
 Chas. Parham,  
 by J. Snowden Bell  
 atty.

# UNITED STATES PATENT OFFICE

CHARLES PARHAM, OF PHILADELPHIA, PENNSYLVANIA.

## IMPROVEMENT IN LOCKS AND CHAIN-FASTENINGS COMBINED.

Specification forming part of Letters Patent No. 188,664, dated March 20, 1877; application filed February 6, 1877.

*To all whom it may concern:*

Be it known that I, CHARLES PARHAM, of the city and county of Philadelphia, in the State of Pennsylvania, have invented certain new and useful Improvements in Door-Fastenings, of which the following is a specification:

The object of my invention is to provide simple and convenient means for enabling the ordinary chain-fastening of street and other doors to be secured either from the outer or the inner side of the door, and in such manner that, while it may be released from the inner side in the usual way, the door cannot be opened (beyond the traverse allowed by the chain) except by the use of a proper key; and, further, to prevent the chain from being released from the outside under any circumstances, when desired, as in the present mode of application and operation of chain-fastenings.

To these ends my improvements consist in combining with a grooved slide-plate open at the end adjacent to the lock side of the door, a movable bolt or stop for the chain-slide and a pin for operating said bolt, as well as in combining these devices with the chain and its slide and with the lock, so that the stop-bolt may be depressed at pleasure to release the fastening, either by the key of the lock or by a special key, as preferred.

My improvements further consist in combining with the open-ended grooved slide-plate a hinged or pivoted check-piece, all as hereinafter more fully set forth.

In the accompanying drawings, Figure 1 is a view in elevation of a portion of a door and its frame with my improvements applied; Fig. 2, a horizontal section of the same; Figs. 3 and 4, views in elevation, showing portions of the lock mechanism in two different positions, and Fig. 5 a view of the movable stop or bolt and starting-pin of the slide-piece with their inclosing-case.

To carry out the objects of my invention, I secure upon the door *F* a slide-piece, *A*, having a horizontal longitudinal groove or recess substantially similar in all essential particulars to those of the slide-pieces heretofore employed, except that it is open at the end next the lock or opening side of the door. A check-piece, *a*, preferably of the **U** form shown in Fig. 1,

is pivoted or hinged to the slide-piece *A* at any convenient point in its length, and serves, under certain circumstances, as a stop for the slide of the chain. The chain *B* is secured at one end to an eye or staple, *b*, upon the door-frame *F'*, and is provided at its free end with a slide, *B'*, of the ordinary form. The door *F* is recessed beneath the groove of the slide-piece *A*, and at a short distance from the open end of the same, to receive a case or box, *C*, within which are arranged a stop or bolt, *C<sup>1</sup>*, and a starting-pin, *C<sup>2</sup>*, each of which is movable at right angles to the slide-piece *A*, and is guided by passing through proper openings in the front and back plates of the case *C*. A spring, *c<sup>1</sup>*, encircles the bolt *C<sup>1</sup>*, and bears against a collar or pin on the bolt and against the front plate of the case *C*, so as to constantly force the bolt *C<sup>1</sup>* inward and prevent it from protruding measurably into the groove of the slide-piece *A*, except when forced outward thereinto, as hereinafter to be explained. A spring, *c<sup>2</sup>*, on the starting-pin maintains the same in the position shown in Fig. 2, except when pushed inward from either side by the slide *B'*. A bent plate, *c<sup>3</sup>*, which I term a "starting-plate," rests against the rear plate of the case *C*, and bears at one end against a pin or collar on the bolt *C<sup>1</sup>*, and at the other against a projection on the starting-pin *C<sup>2</sup>*. The starting-plate acts as a lever of the first order to push the bolt *C<sup>1</sup>* a short distance outward into the groove of the slide-piece when the pin *C<sup>2</sup>* is pushed inward, the traverse which it imparts to the bolt *C<sup>1</sup>* being dependent upon its length and the angle at which it is bent; or, in other words, upon the leverage of its arms. The traverse of the bolt due to the starting-plate need not, however, be very great, as said plate is only designed to act preliminarily as an auxiliary to a device connected with the lock the nature and operation of which is as follows: A vertical lever, *E*, is pivoted to the lower portion of the lock-case *D* adjacent to the key-lever *d*, by which the latch-bolt *d'* is moved. The upper end of the lever *E* is pivoted or jointed to one end of a horizontal bar, *E'*, which slides in guides parallel to, and in rear of, the slide-piece *A*. The opposite end of the bar *E'* is mitered or beveled, and the inner end of the bolt *C<sup>1</sup>* is

correspondingly beveled, as shown in Fig. 2. A spring, *e*, bears against the lever *E* and tends constantly to force its upper end, and with it the bar *E'*, into the positions shown in full lines in Figs. 2 and 3. The action of the latch-key upon the key-lever *d* serves to move the lever *E* and bar *E'* into the positions shown in full lines in Fig. 4, and in dotted lines in Figs. 2 and 3, where they will be held by a spring, *e'*, one end of which is secured to the bar *E'*, the other end bearing against a stop or abutment, *e''*, adjacent to the inner end of the starting-pin *C'*. When the parts occupy said last-named positions the bolt *C'* will be forced inward in the case *C* by its spring *e'*, and the slide *B'* can be moved freely past it along the groove of the slide-piece *A*. Upon the application of pressure to the starting-pin *C'* by the slide *B'* from either end of the slide-piece, the inward movement of said starting-pin will first move the bolt *C'* a short distance into the groove of the slide-piece by means of the starting-plate *c'*, and immediately thereafter will release the spring *e'* from the stop *e''*, when the spring *e* being free to exert its tension will force the lever *E* and bar *E'* into the positions shown in full lines in Figs. 2, 3, and 4, the beveled end of the bar *E'* in its traverse forcing the bolt *C'* sufficiently far out into the groove of the slide-piece to act as a stop to prevent the slide *B'* from being drawn out toward and through the open end of the slide-piece. The bar *E'* locks the bolt *C'* securely in this position, and prevents its withdrawal from the groove until said bar is drawn back by the action of the latch-key, as hereinbefore described.

I have described and shown the bar *E'* as operated by the same key as the latch, such an arrangement being preferred by me by reason of its simplicity; but it is obvious that said bar might be actuated by a separate and special key, if preferred, without in anywise departing from the spirit of my invention.

In cases where it is desired that the chain fastening should not under any circumstances be released from the outside of the door, the pivoted check piece or stop *a* is turned over so as to engage notches *a'* in the slide-piece, and the slide *B'* inserted in the opening *a''* in the rear end of the slide-piece. The pivoted check-piece will then act as a stop to the slide

*B'* in a similar manner to the stop or closed end of the ordinary fastening, with the advantage, however, that its use is of course optional.

By this construction a chain-fastening may be secured as readily from the outside as from the inside of the door, and when secured it can be released in the ordinary manner from the inside of the door, but not from the outside, except by the use of a proper key. It is further obvious that the provision of the hinged check enables the fastening to be secured against being released from the outside even by the proper key whenever such arrangement should become necessary or desirable.

I am aware that a chain-fastening combined with a door-lock, and so arranged as to be operated and released from the opposite side of the door to which it is attached, has been heretofore known and patented, and I do not, therefore, broadly, claim such device.

I claim as my invention and desire to secure by Letters Patent—

1. The combination of a grooved slide-piece having a free opening at the end adjacent to the lock side of the door with a check piece or stop hinged or pivoted to the slide-piece, so as to be swung across the same to prevent the withdrawal of the chain-slide through its open end, substantially as set forth.

2. The combination of a slide-piece, the groove of which has a free opening at the end adjacent to the lock side of the door, and a sliding stop or bolt which is movable at right angles to the groove of the slide-piece, and is forced into the same by the pressure of the chain-slide, substantially as set forth.

3. The combination of a grooved slide-piece, a movable stop or bolt, and a starting-pin, substantially as set forth.

4. The combination of a grooved slide-piece, a movable stop or bolt, and a starting-plate, substantially as set forth.

5. The combination of a grooved slide-piece, a movable stop or bolt, a sliding bar which moves and locks said bolt, and a pivoted lever operating said sliding bar, substantially as set forth.

CHAS. PARHAM.

Witnesses:

J. SNOWDEN BELL,  
GEORGE BURDICK.