

F. A. RICH.
GAGING AND CENTERING TOOLS.

No. 188,756.

Patented March 27, 1877.

Fig. 1.

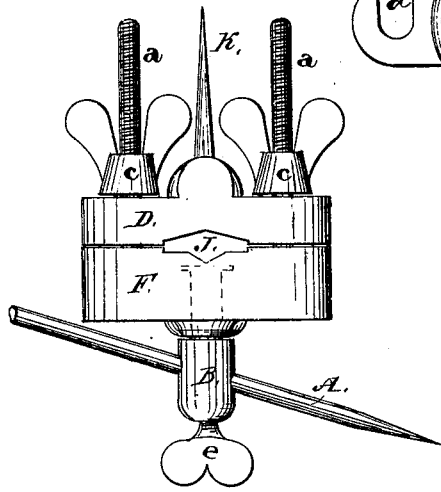

Fig. 2.

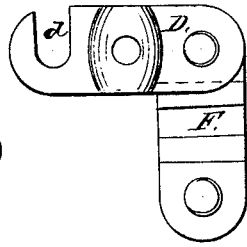

Fig. 3.

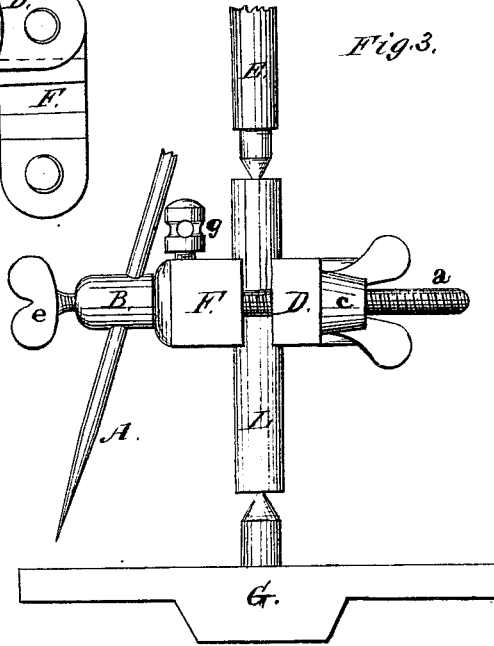
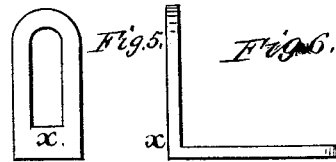
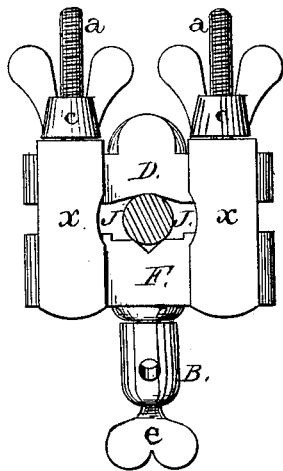

Fig. 4.



Witnesses:

John W. Van Leunen
Ph. Canden Heuwel

Inventor:

Francis A. Rich

F. A. RICH.

GAGING AND CENTERING TOOLS.

No. 188,756.

Patented March 27, 1877.

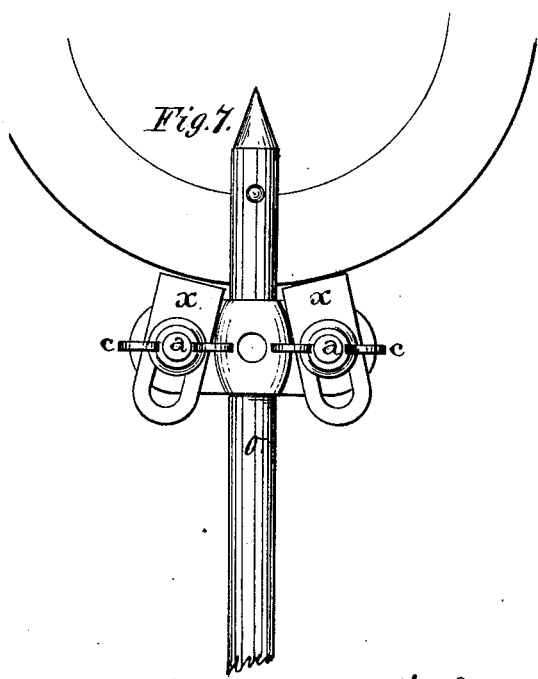

Fig. 7.

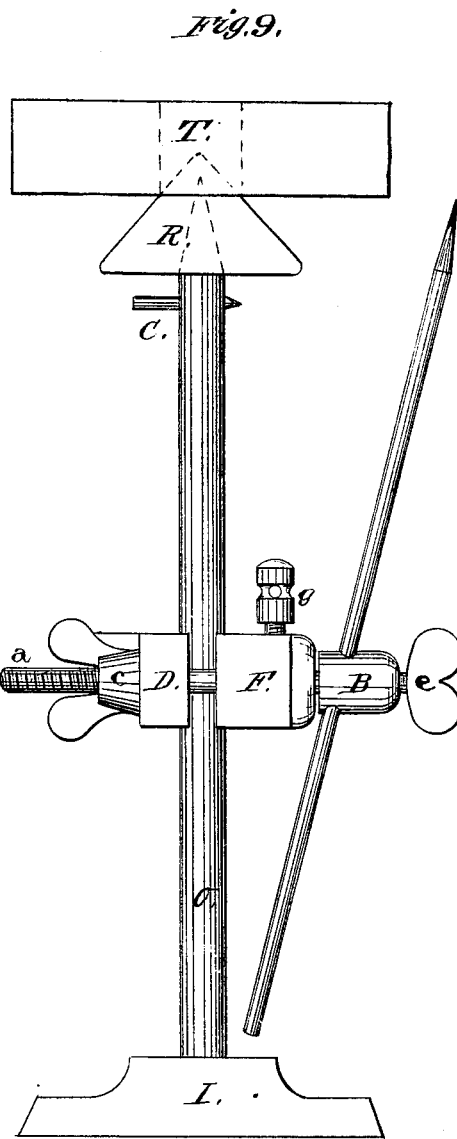

Fig. 9.

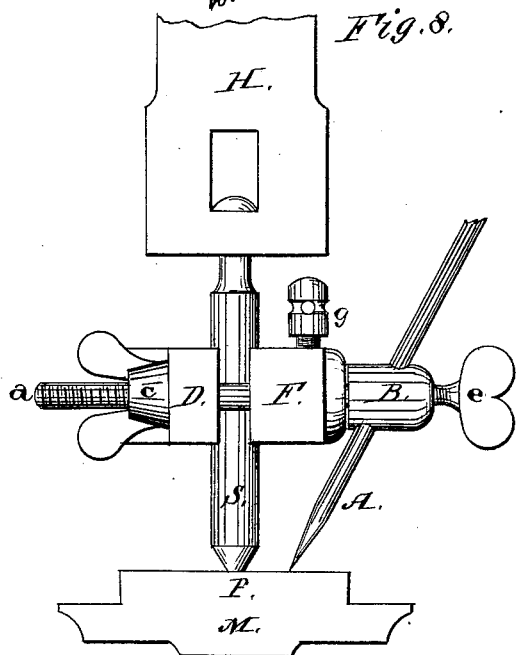

Fig. 8.

Witnesses:

John W. Van Leeuwen
J. H. Vanden Houvel

Inventor:

Francis A. Rich

UNITED STATES PATENT OFFICE

FRANCIS A. RICH, OF GRAND RAPIDS, MICHIGAN, ASSIGNOR OF ONE-THIRD OF HIS RIGHT TO JOHN H. JONES, OF SAME PLACE.

IMPROVEMENT IN GAGING AND CENTERING TOOLS.

Specification forming part of Letters Patent No. 188,756, dated March 27, 1877; application filed February 23, 1876.

To all whom it may concern:

Be it known that I, FRANCIS A. RICH, of the city of Grand Rapids, county of Kent and State of Michigan, have invented a Centering Compass and Gage, of which the following is a specification:

My invention relates to an improvement in centering compasses and gages; and it consists in the arrangement and combination of clamps, scribes, stut-bolts, and thumb-nuts that will be more fully described hereinafter, whereby a cheap, simple, and effective instrument is produced for centering, leveling, boring, turning, and drilling all kinds of machinery.

Figures 1, 3, 4, 7, 8, 9 show my device as applied to different kinds of work. Figs. 2, 5, 6 are detail views of the same.

Letters D and F represent two clamps, which are secured together by the screws *a* and thumb-nuts *c*, the part D being thinnest, and having a recess, *d*, in one end for convenience of opening, as shown in Fig. 2. In the center of the inner sides of these clamps is made a groove, J, for the reception of a flat bar, a rod, or bolt, to which the clamps are to be fastened. To the part F is swiveled a pin, B, which has a hole through it at an angle of about twenty degrees to receive a scribe, A, which is held in any desired position by the thumb-screw *e*.

The pin B is held in any desired position by means of a set-screw, *g*, after it has once been adjusted for the scribe. Passing over the two screws *a* are the two slotted right-angular plates, *x*, which are used in gaging,

as shown in Fig. 7, and may be used either upon straight or curved surfaces, the rod O having a marker, C, projecting out from its side for this purpose.

The hole through the pin B is made at an angle of about twenty degrees, so that the scribe can be set for small or large circles, as shown in Figs. 3, 8, and 9.

In Fig. 3 my device is shown attached to a rod, L, which is held in a lathe, with the scribe A, in position for centering on the face-plate G. In Fig. 7 the gage is shown adjusted for drawing an inside circle; but outside circles may be made just as well by reversing the parts. In Fig. 8 the gage is shown attached to a drill, S, which is fastened in the spindle H. The scribe A is set for leveling the piece P on the table M, and can be used as well with a ratchet as a press-drill. In Fig. 9 the cone R is shown attached to the sharp end of the rod O, and the scribe set to an outside angle to draw a circle on the piece T. The bottom plate I is adjusted to form a surface-gage to the rod O. To the part D is secured a stationary scribe, K, which, with the movable scribe A, forms a compass.

Having thus described my invention, I claim—

The combination of the clamps D F, screws *a*, nuts *c*, head or pin B, scribe A, set-screw *g* and *x*, round or flat bar O, substantially as shown and described.

FRANCIS A. RICH.

Witnesses:

J. H. JONES,
M. B. COOPER.