

**B. BEVELANDER.**

**MACHINE FOR FINISHING HORSESHOE NAILS.**

No. 188,770.

Patented March 27, 1877.

*Fig. 1.*

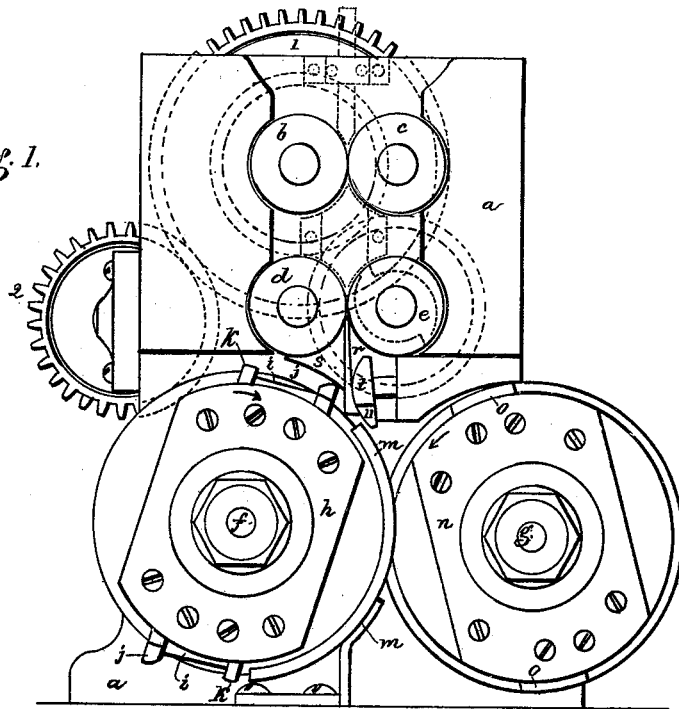

*Fig. 2.*

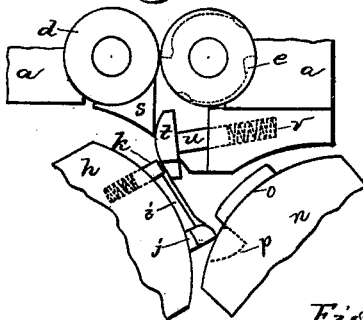

*Fig. 3.*

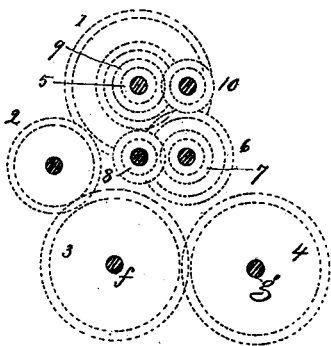

*Fig. 4.*

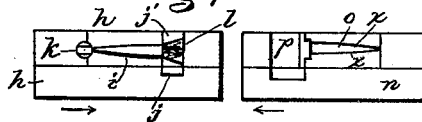

*Witnesses.*  
*C. B. Perkins.*  
*W. J. Pratt.*

*Inventor.*  
*Benjamin Bevelander*  
*per Conyby Irving Atty.*

# UNITED STATES PATENT OFFICE

BENJAMIN BEVELANDER, OF BOSTON, MASSACHUSETTS, ASSIGNOR TO  
GLOBE NAIL COMPANY.

## IMPROVEMENT IN MACHINES FOR FINISHING HORSESHOE-NAILS.

Specification forming part of Letters Patent No. 188,770, dated March 27, 1877; application filed  
February 12, 1877.

### *To all whom it may concern:*

Be it known that I, BENJAMIN BEVELANDER, of Boston, in the county of Suffolk and State of Massachusetts, have invented an Improved Horse-Nail Machine, of which the following is a specification:

This invention relates to improvements in machines for cold-drawing the body and shearing the spread point of a horse or animal shoe nail at a continuous operation, and is an improvement on Patent No. 121,511.

In that patent the nail-blank, drawn and flattened at its point by the action of two pairs of die-rollers, is caught by a pair of reciprocating jaws and presented to the action of a punch, which forces the rolled blank through a stationary die, thereby shearing the point and sides of the drawn blank, giving it its proper shape for a horse-nail. That machine is much restricted as to its speed by reason of the reciprocating jaws having to traverse the length necessary to remove a drawn blank from the last pair of rollers to a position to be released by the operation of a reciprocating punch.

This invention consists in the combination, with die-rolls to spread and bevel the point of the nail-blank, or with rolls to cold-draw the body of the blank and spread its point, of a rotating punch and die, to shear the blank after leaving the rollers to form the nail body and point, whereby the speed of the machine and the quantity of work performed by it is greatly increased without the expenditure of additional power.

The invention also consists in the combination, with a rotating punch and die, of jaws adapted to move with the punch and hold the head of the nail-blank while the punch and die shear the nail, substantially as described; also, in the combination, with a rotating die and punch, and jaws to operate as herein described, of a chip-holder, to hold the surplus portion of metal sheared from the extreme point of the blank, and discharge it, substantially as described; also, in the combination, with the die-rollers and rotating jaws, of a yielding finger to hold the rolled blank after its passage between the rollers, until caught by the rotating jaw; also,

in the combination, with a rotating nail-blank-carrying jaw, of a yielding finger, shaped to act upon the body of the blank after it is caught by the jaw, to press the blank down in position upon the punch; also, in the combination, with a rotating head-holding jaw, of a punch and yielding chip-holding device, to operate substantially as described.

Figure 1 represents sufficient of an animal-shoe-nail-machine to delineate my invention; Fig. 2, a detail thereof in another position; Fig. 3, a detail of the gearing to operate the different shafts of the machine, and Fig. 4 a detail of the rotating punch and die.

The frame *a* of the machine will be made of suitable shape to support the working parts. The die-rollers *b c* and surface-finishing and point rollers *d e* are substantially such rollers as are represented in United States Patent No. 121,511, both as to construction and operation. The nail-blank guides above and below the die-rollers *b c* are shown in Fig. 1 in dotted lines.

A toothed wheel, 1, on shaft of roller *b*, engages toothed wheel 2, it operating toothed wheel 3 on shaft *f*, meshing with wheel 4 on shaft *g*. Pinion 5 on shaft of roll *b* engages pinion 6 on shaft of roll *e*, such shaft having a pinion, 7, meshing with pinion 8 on shaft of roll *d*. The shaft of roll *b* also carries a pinion, 9, engaging with a pinion, 10, on shaft of roll *c*. The shaft *f* carries a rotating head, *h*, provided with one or more punches, *i*, jaws *j j'*, and chip-holders *k*. The punches are adjustably secured in the rotating head. The member *j* of the pair of jaws *j j'* is operated upon by a suitable spring, (shown in dotted lines at *l*, Fig. 4,) to separate it from jaw *j'* when not positively acted upon by the cam-plate *m*. The head *n* on shaft *g* carries one or more sets of dies, *o*, preferably composed of two members, as shown in Fig. 4, adjustably secured to the head by suitable set-screws. The die *o* is recessed to permit the punch *i* to force the body and point of the nail-blank into it below its cutting-edges *x x*, and in front of the die is an opening or recess, *p*, to receive the jaws *j j'* as the heads *h n* rotate. The nail-blank *r*, with one side

finished and the point beveled and spread, is moved by the finishing and point rolls *d e* down between a guide-surface, *s*, and a yielding finger, *t*, on a rod, *u*, held out toward the nail-blank and guide-surface by a suitable spring, *v*. As indicated in Fig. 1, the nail has been fed down between the guide-surface and finger, and the jaws are just coming into position to grasp the head of the blank. The jaws engage the inclined edges of the head, and on reaching the cam-guard *m* the jaw *j* is closed sufficiently to cause the jaws to grasp the head firmly and carry it from between the guide-surface *s* and finger *t*, the latter yielding or sliding backward. The lower end of the finger at *11* is sufficiently narrow to pass between the jaws and bear upon the nail-blank at or near the head, central as to the body of the blank, and consequently the finger, as the head and jaw rotates, throws the nail-blank down upon the punch *i*, the spread point of the blank resting upon the chip-holder *k*, supported upon a suitable spring. (Shown in dotted lines, Fig. 2.)

As the heads continue to rotate from the position shown in Fig. 2, the jaws and blank head enter the recess *p* in the head *n*, in advance of the die *o*, and as the punch comes in position opposite the die the point of the nail and a portion of the body are driven into the die-opening by the punch, and sheared to the form the finished nail is to retain.

The punch and die operate gradually, shearing the nail from the body toward the point. During the shearing operation, and until the jaw *j* passes the cam or guard *m*, the jaws hold the nail. This guard *m* will preferably extend to about the lowermost portion of the arc in which the punch travels, in order that the jaws may retain the head of and carry the nail to a position to be discharged into a suitable receptacle. The nail will preferably be discharged after the chip cut from the point of the nail is released, such chip being held after the operation of the punch and die by the chip-holder *k*. The chips first discharged will fall into one space and the nails carried farther into another space, which will prevent the nails and chips or shearings from becoming mixed. The shearings contain sharp points, which, when mixed with the nails, are liable to injure the hands of the person handling them.

The shape of the finger and the punch and die may be varied without departing from the invention.

With a rotating punch and die the capacity of the machine is greatly increased over that of the machine having the usual reciprocating transferrer.

The punch and die rotating in the same direction are brought together to shear the nail-blank gradually, with what is called a "shear-cut," and the cut is not by a blow, as if a movable punch operated in connection with a stationary die.

I claim—

1. The combination of die-rolls to spread the point of a nail-blank with a rotating punch and a rotating die to shear the nail-blank, substantially as described.

2. The combination, with die-rolls to cold-draw and spread the points of nail-blanks, of a rotating punch and a rotating die to shear the nails, all substantially as described.

3. The combination, with a rotating punch and a rotating die, of independently-actuated jaws, adapted to move with the punch and die, and mechanism to actuate the jaws, whereby they grasp the head of the nail-blank and hold it before, during, and after the action of the punch and die upon the blank to shear it, substantially as described.

4. A rotating die and rotating punch, and jaws to hold the head of the blank, as described, in combination with a chip-holder to hold the surplus metal sheared from the flattened point of the nail-blank, and discharge the chip before the blank is discharged, substantially as described.

5. The die-rolls *d e* and rotating jaws, in combination with a guide-surface and yielding finger, to hold the nail-blank for the jaws to grasp it, substantially as described.

6. The rotating jaw and punch, in combination with a yielding finger to act upon the nail held by the jaws and crowd it down upon the punch, substantially as described.

7. The combination, with a rotating punch and die, and jaws and guard adapted to hold the nail-head, of a yielding chip-holder to hold the surplus metal sheared from the point of the nail, and permit its discharge before the discharge of the nail, substantially as described.

In testimony whereof I have signed my name to this specification in the presence of two subscribing witnesses.

BENJAMIN BEVELANDER.

Witnesses:

G. W. GREGORY,  
S. B. KIDDER.