

M. BRAY.
MACHINE FOR DRILLING THE SHANKS OF RIVETS.
No. 188,773. Patented March 27, 1877.

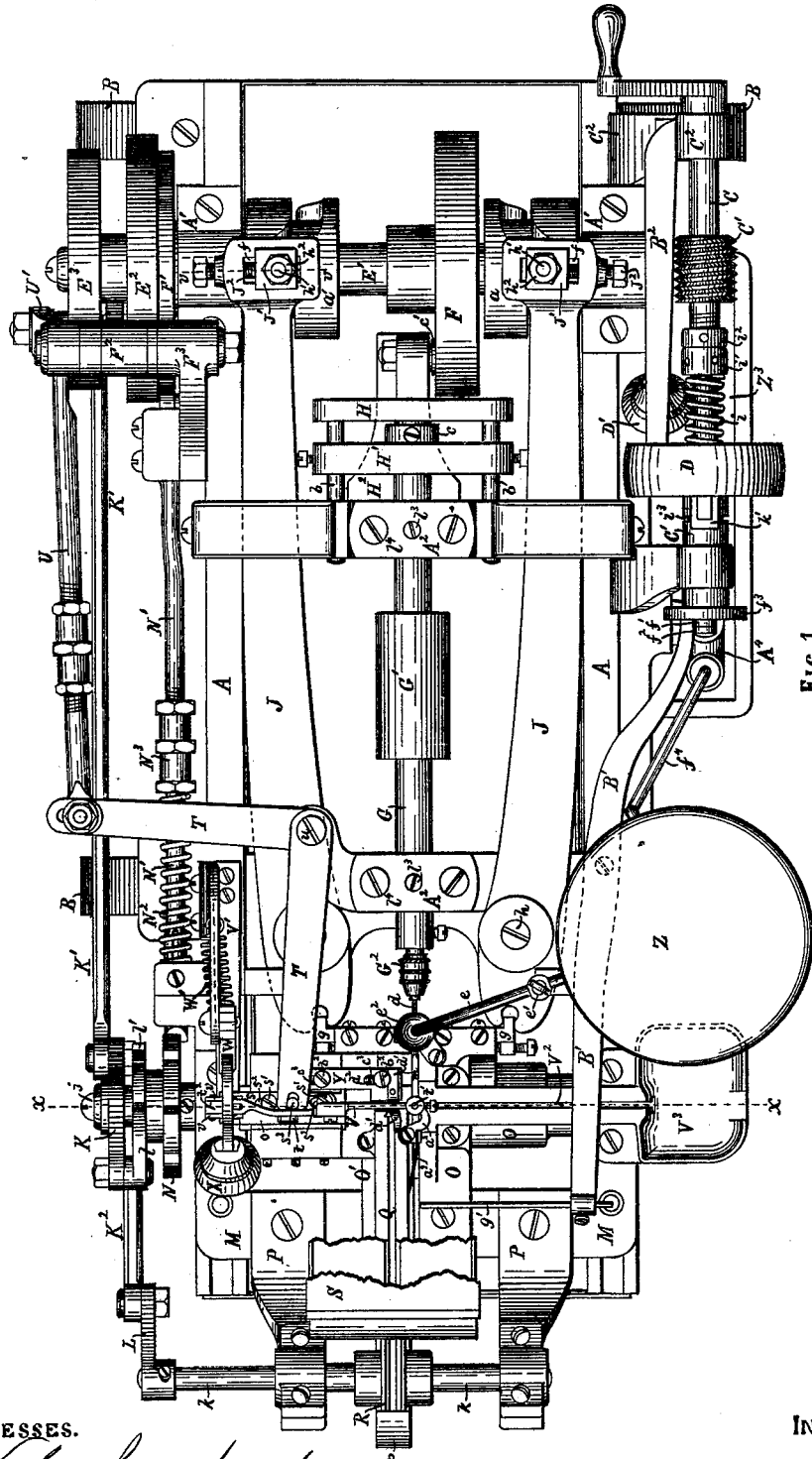

FIG. 1.

WITNESSES.

N. C. Lombard
C. A. Hemmerway.

INVENTOR.

Mellen Bray.

M. BRAY.

MACHINE FOR DRILLING THE SHANKS OF RIVETS.
No. 188,773.

Patented March 27, 1877.

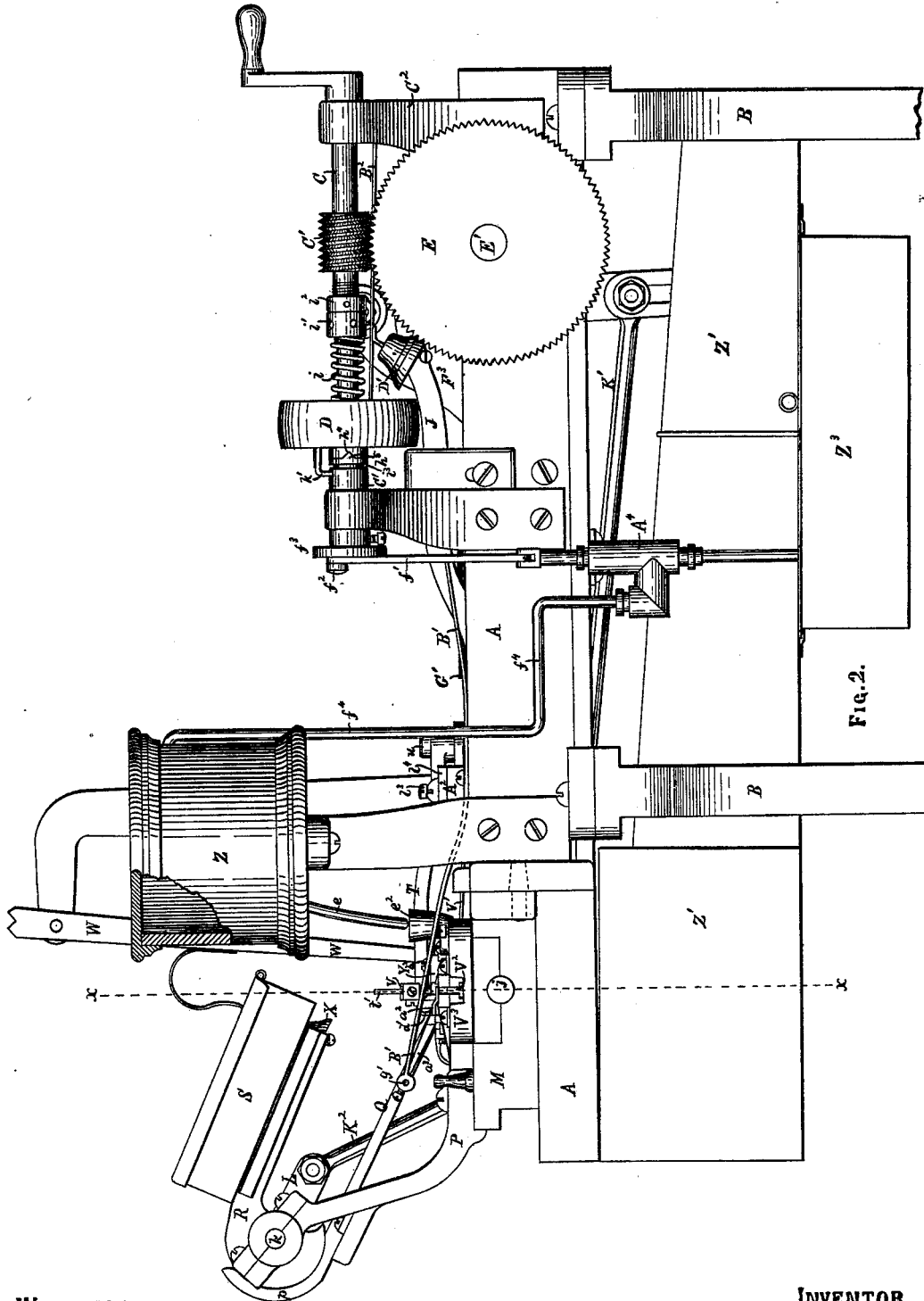

Fig. 2.

WITNESSES.

N. C. Lombard
E. A. Kemmenway

INVENTOR.

Mellen Bray

M. BRAY.

MACHINE FOR DRILLING THE SHANKS OF RIVETS.
No. 188,773. Patented March 27, 1877.

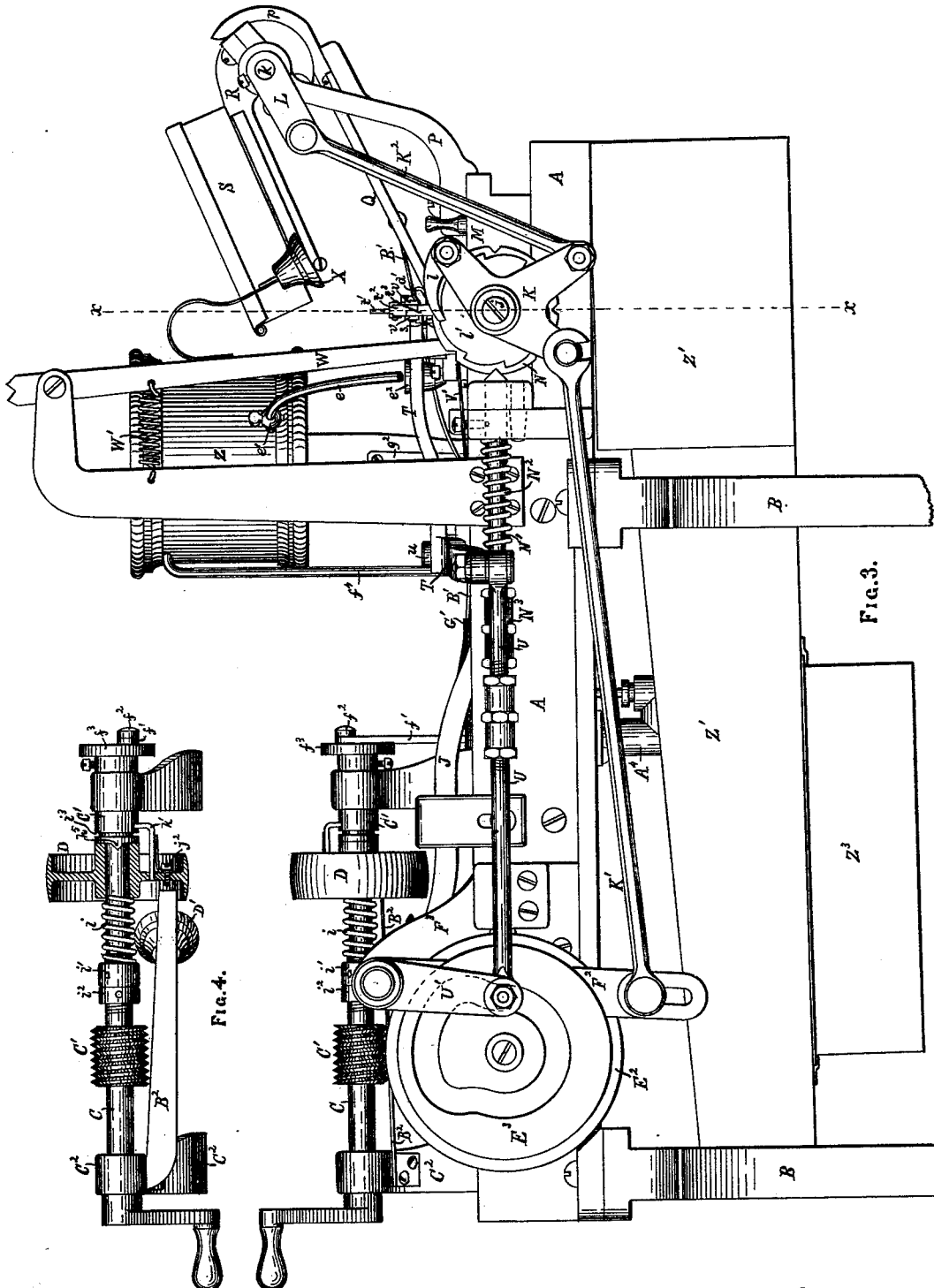

WITNESSES.

N. C. Lombard
E. A. Hemmenway

INVENTOR.

Mellen Bray.

M. BRAY.

MACHINE FOR DRILLING THE SHANKS OF RIVETS.

No. 188,773.

Patented March 27, 1877.

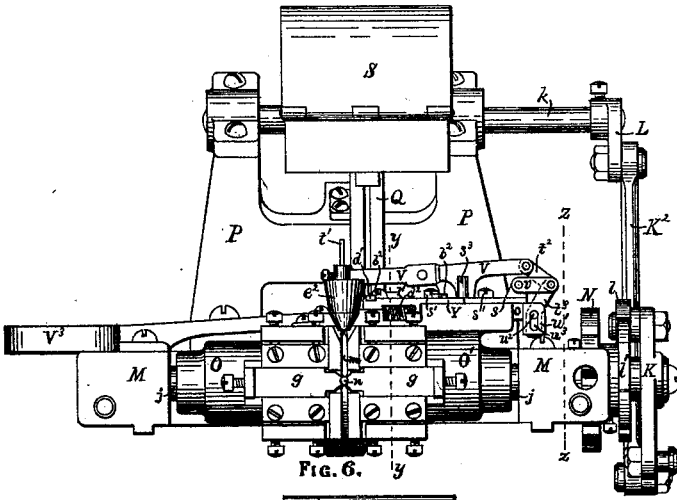

FIG. 6.

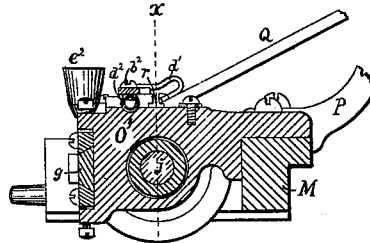

FIG. 8.

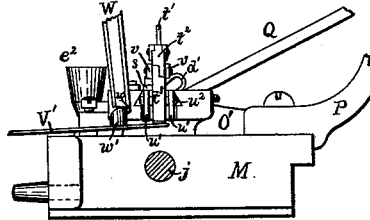

FIG. 9.

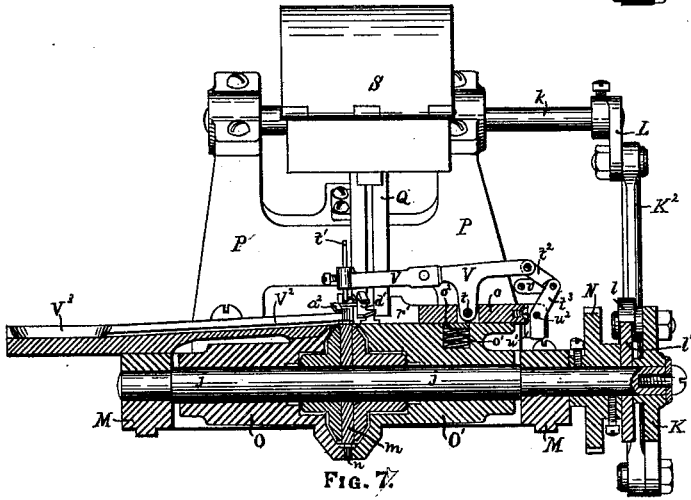

FIG. 7.

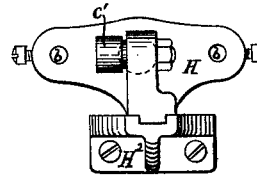

FIG. 13.

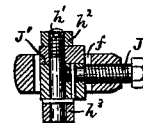

FIG. 12.

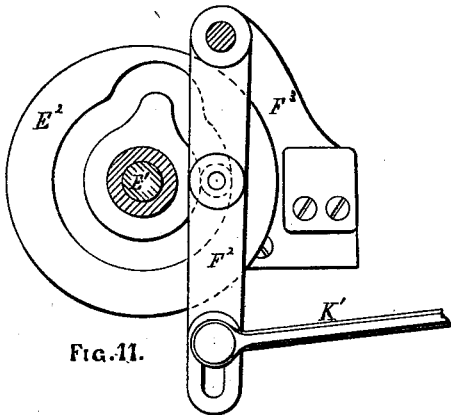

FIG. 11.

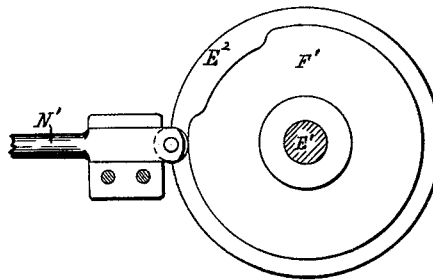

FIG. 10.

WITNESSES.

N. C. Lombard
E. A. Kemmenway

INVENTOR.

Mellen Bray

UNITED STATES PATENT OFFICE.

MELLEN BRAY, OF NEWTON, MASSACHUSETTS.

IMPROVEMENT IN MACHINES FOR DRILLING THE SHANKS OF RIVETS.

Specification forming part of Letters Patent No. 188,773, dated March 27, 1877; application filed October 2, 1876.

To all whom it may concern:

Be it known that I, MELLEN BRAY, of Newton, in the county of Middlesex and State of Massachusetts, have invented certain new and useful Improvements in Drilling-Machines for Forming the Hollow Shanks of Tubular Rivets, of which the following, taken in connection with the accompanying drawings, is a specification.

My present invention relates to a machine for drilling out the body or shank of a rivet after the rivet has been formed by a previous operation, so as to make said shank a thin hollow tube, capable of being clinched upon the material in which it is set by turning the end of said tubular shank over onto the material in the same manner that eyelets are set, and is an improvement upon the invention described in Letters Patent No. 166,963, granted to me August 24, 1875.

My invention consists, first, in mounting the clamping dies or jaws, which seize and hold the rivet while it is being drilled, upon the supplementary or movable frame which carries the intermittently-rotating carrier-wheel, and other rivet separating and feeding devices, and adapting said clamping-jaws to be coupled with the operating-levers for imparting motion thereto, mounted on the main frame, when the supplementary frame is secured in position on the main frame, and to be readily disengaged from said levers by moving said supplementary frame back on the main frame, as will be described.

My invention further consists in the use, in combination with an intermittently-rotated carrier-wheel, provided with pockets in its periphery to receive and carry in succession a series of rivets to a position in front of the drill, an inclined chute, down which said rivets slide in a single line, with their heads all in one direction, and a reciprocating plunger arranged to move in a suitable channel-way, and feed the rivets successively from the foot of the inclined chute into the pockets of the carrier-wheel of a discharge-chute or channel-way, extending from the carrier-wheel opposite to the reciprocating plunger which feeds the rivets into the wheel, all so arranged that the feeding of an undrilled rivet into a pocket of the carrier-wheel shall discharge from the

same pocket a drilled rivet into said discharge channel-way with its head downward.

My invention further consists in forming upon the outer end of said discharge-chute or channel-way a broad, shallow, flat-bottomed tray or receptacle, the upper surface of the bottom of which coincides with the bottom of the discharge end of the groove in said channel-way, in which the discharged rivets may accumulate until inspected by the operator.

My invention further consists in the use, in combination with an inclined chute, down which the rivets slide in a single line with their heads all in one direction, and a reciprocating plunger arranged to move in a suitable channel-way at right angles to said chute, and feed the rivets successively from the foot of the inclined chute, of a reciprocating wedge, adapted to pass between the lower rivet in the inclined chute and those above it, forcing said lower rivet into the horizontal channel-way in front of the feed-plunger, and retaining those above it in their position in the chute till the feed-plunger has passed the end of the inclined chute in its movement toward the carrier-wheel, and then recede to allow the rivets to descend the chute till the lower one rests against the side of the feed-plunger.

My invention further consists in the use, in combination with an intermittently-rotating carrier wheel or disk, provided with a series of pockets in its periphery, each adapted to receive a rivet and convey it to the drilling-tool, a pair of clamping-dies, an automatically-operated drill, and a detent-wheel, having formed in its periphery as many notches or detents as there are pockets in the carrier-wheel, and mounted upon the shaft of said carrier-wheel, of a reciprocating detent-rod, arranged in a position radial to the axis of the detent-wheel, and a cam, arranged and adapted to move said detent-rod endwise, and force its end into a notch in the detent-wheel, to correct any inaccuracy in the position of the carrier-wheel relative to the drill, and lock it in such position till again released by the rotation of said cam after the drill has completed its work upon the rivet, and been withdrawn therefrom.

My invention further consists in mounting said anti-friction trucks, upon which the cams

act to operate the clamping-levers, upon studs set in rectangular boxes or blocks fitted to slots made through the ends of the long arms of said levers, and adapted to be adjusted transversely of said levers by means of set-screws working in nuts formed in said levers, and bearing against said blocks for the purpose of regulating the pressure of the clamping-jaws upon the rivet, and to compensate for the wear of the parts.

My invention further consists in making each of said rectangular boxes or blocks in two parts, the line of separation being parallel to the upper and lower surfaces of that portion of the lever into which they are to be inserted, and each of said parts being provided with a lip or lips, to bear upon the upper and under side of the lever, in combination with a stud to carry the anti-friction truck, provided with a shoulder or collar to bear against the under side of the lower portion of the box, a shank extending up through both parts of the box, and a nut bearing upon the upper portion of the box, to bind the two parts together, and both to the lever, by forcing the lips on the two parts of the box hard upon the upper and under surfaces of the lever.

My invention further consists in the combination, with an inclined chute, of a feed-plunger, to take a rivet from the foot of the chute and feed it to the carrier-wheel, a lever, a connecting-rod, and a positive-motion cam, all connected together, and co-operating to impart to said plunger a positive endwise motion in both directions.

My invention further consists in the use, in combination with an automatically-operated drill, an intermittently-rotated carrier-wheel, and a pair of clamping-jaws for holding the rivet while being drilled, of an elevated oil-tank, a suitable discharge-pipe, provided with a cock to regulate the flow of oil, and a funnel to receive the oil from the pipe, and direct it upon the drill.

My invention further consists in the use, in a drilling-machine, provided with an elevated tank to supply oil to the drill, of a receiving-tank, placed below the drill, in position to catch the oil and the chips cut by the drill, and having a bottom slightly inclined, so that the oil will drain away from the chips; a secondary tank, placed at a lower level, into which the oil drains from the receiving-tank; and a pump, adapted to draft from said secondary tank and discharge into the elevated tank, from which it again flows by the action of gravity to lubricate the drill.

My invention further consists in the use, in combination with an intermittently operated carrier-wheel, provided with a series of pockets in its periphery, each adapted to receive and carry a rivet to the drilling-tool, an inclined chute, and a reciprocating plunger, arranged to move in a suitable channel-way and feed the rivets successively from the foot of the chute to the pockets in the carrier-wheel, of an automatically-operating stop mechanism

adapted to test every rivet that has passed the drill, and, if it is drilled to the proper depth, discharge it from the wheel into the discharge-chute or channel-way; but if, for any reason, a rivet should pass the drill and arrive at the place for discharge without being completely drilled, the same mechanism will cause the stoppage of the machine and sound an alarm, the details of which mechanism will be best understood in connection with the description of the drawings.

My invention further consists in the use, in combination with an intermittently-rotated carrier-wheel, provided with a series of pockets, an inclined chute, down which the rivets slide in a single line, a reciprocating plunger, adapted to feed the rivets in succession from the foot of said inclined chute to the carrier-wheel, and a discharge-chute or channel-way in line with the feed plunger, of a pivoted or spring-operated gate, extending across said discharge-chute or channel-way parallel with and close to the side of the carrier wheel, and adapted to swing to one side to allow the passage of a rivet, and then spring back to its normal position to close the side of the pocket in the carrier-wheel, and prevent the solid rivet being fed into the pocket from being thrown too far.

My invention further consists in the use of a driving-pulley mounted loosely upon its shaft so as to revolve freely thereon, and made to engage therewith and impart motion thereto by means of a detent notch cut in one end of its hub, and a corresponding tooth set in or formed upon the shaft, and a spring adapted to move said pulley in the direction of the length of the shaft and cause said tooth and notch to engage, said tooth and notch having their bearing sides made tapering, or at an angle to the axis of motion about which said pulley revolves, so that if, for any reason, the resistance to the rotation of the cam-shaft is increased beyond a given point the driving-pulley will be moved on its shaft, disengaging the tooth from the notch, and said pulley will revolve upon its shaft without imparting motion to the several parts of the machine.

My invention further consists in the use, in combination with a driving-pulley fitted to revolve freely upon its shaft, or to be engaged therewith and impart motion thereto by being moved along said shaft in the direction of its length by the pressure of a spring, and adapted to be disengaged again by an increase of resistance of a spring-pawl attached to and revolving with the pulley, and a circumferential groove cut in the shaft in such a position that when the driving-pulley is disengaged from its shaft by being moved along said shaft against the tension of the spring said pawl will drop into said groove and prevent further engagement of the pulley with the shaft till attended to by the operator.

My invention further consists in combining, with said loosely-attached driving-pulley, a bell, so arranged that when said pulley is re-

involved upon its shaft said bell will continue to sound an alarm to call the attention of the operator to the fact that something is wrong with the machine.

My invention further consists in mounting the drill-spindle in bearings having a mortise made radially through that half toward which the belt which drives the spindle draws, into which is fitted a half box made of a block of Babbitt metal, or other suitable bearing composition, in such a manner that it may be moved radially therein, in combination with a follower-plate resting upon the top or outer end of said half box, and a set-screw adapted to bear upon said follower and force said half box toward the shaft to take up the wear and keep the drill-spindle in line.

My invention further consists in the combination with a drill-spindle mounted in bearings in such a way that it may be rotated and moved endwise therein, and provided with a collar at its rear end, a yoke adapted to bear against the rear end of said spindle, and also embrace said spindle forward of its collar, and provided with one or more guide-pins to prevent rotation thereof by the revolution of the drill-spindle of a path-cam adapted to impart to said yoke, and through it to the drill-spindle, a positive forward and backward motion, and a stand adapted to support said yoke nearly under the point acted upon by the cam to prevent the downward thrust of the cam from unduly springing said yoke and causing it to bind upon the drill-spindle.

Figure 1 of the drawings is a plan of my improved automatic drilling-machine. Fig. 2 is a front side elevation, with a portion of the oil-supply tank shown in section. Fig. 3 is a back side elevation. Fig. 4 is a sectional elevation of the driving-shaft and its appendages. Fig. 5 is a central vertical and longitudinal section. Fig. 6 is an elevation of the inner end of the supplementary or removable frame, and the rivet separating, feeding, and testing devices mounted thereon. Fig. 7 is a transverse section of the supplementary carrier-wheel and the shield-stands on line *x x*, on Figs. 1, 2, 3, 5, and 8. Fig. 8 is a vertical section on line *y y* on Fig. 6. Fig. 9 is a section through carrier-wheel shaft on line *z z* on Fig. 6, showing supplementary frame and stop mechanism in elevation. Fig. 10 is a detail illustrating the relation of the detent locking-bolt to the cam for operating it. Fig. 11 is an elevation of the cam, cam-lever, and a portion of the connecting-rod for imparting an intermittent rotary motion to the carrier-wheel. Fig. 12 is a transverse section of the lever for operating the clamping-jaw on line *v v*, and illustrating the manner of applying and adjusting the cam-truck. Fig. 13 is an end elevation of the drill-spindle yoke, and the stand for supporting the same.

The same letters of reference refer to the same parts in all of the drawings.

A is the main frame of the machine mount-

ed upon suitable legs B, portions only of which are shown.

C is the driving-shaft, operated by a belt, (not shown,) acting upon the pulley D, and provided with the worm C¹, which meshes into and acts upon the worm-wheel E secured to the outer end of the shaft E¹, which is mounted in the bearings A¹ A¹ on the frame A, and has mounted thereon between said bearings, the disk path-cam F, and the two cylinder path-cams *a* and *a*¹.

G is a drill spindle mounted in bearings A² A² of the frame A in such a manner that it may be revolved and moved endwise therein at the same time, and provided with the pulley G¹, by means of which and a belt (not shown) rotary motion is imparted thereto.

H H¹ is a yoke made in two parts, connected together by the rods *b b*, which fit into suitable holes in the bearing A², one part H of the yoke bearing against the rear end of the spindle G, and the part H¹ surrounding the spindle in front of the collar *c* formed on the rear end of said spindle, in such a manner that, while the spindle may be revolved about its axis at a high rate of speed without imparting any movement to the yoke, any motion imparted to said yoke in the direction of the length of the spindle either forward or backward will cause a corresponding motion of the spindle.

The yoke H H¹ is provided upon its under side with the tongue or slide 3 fitted to and adapted to reciprocate in the groove 4 formed in the upper side of the stand H², and carries the cam-truck *c*¹, which fits into the path *c*² in the cam F, by means of which a positive endwise motion in both directions is imparted to the drill-spindle to feed the drill to its work and withdraw it from the rivet when the drilling is completed.

Upon the forward end of the spindle G is screwed a drill-chuck, G², in which is carried a drill, *d*, of suitable size, and adjusted to the proper length to drill the rivet to the required depth when the cam F *c*² has forced the spindle G to the extreme of its forward motion.

J J are two levers arranged upon opposite sides of the drill-spindle and equidistant therefrom, having formed in their front ends slots to engage with the clamping-jaws *g g*, and pivoted at *h* to the frame A, the long arms of said levers extending toward the rear of the machine, and having formed therein, directly over the cams *a* and *a*¹, slots *f f*, in which are fitted, so as to be readily adjusted transversely of said levers, the rectangular boxes J¹, each made in two parts, provided with lips, and clamped together, so as to cause said lips to bear hard upon the upper and under surface of said levers by means of a binding-bolt, *h*¹, and nut *h*², the adjustment of said boxes being effected by means of the screws J² J² working in screw-threads formed in the stock of said levers, and connected to

said boxes so as to impart thereto a positive motion in both directions.

The binding-bolts h^1 also carry the cam-trucks h^3 , which fit into, and are acted upon by, the paths formed in the peripheries of the cylinder-cams a and a^1 , which serve to impart to the levers J J an equal and simultaneous motion in opposite directions.

The shaft E^1 has, secured to the end opposite to the worm-wheel E , and outside of the frame A, the path-cams E^2 and E^3 and the face-cam F^1 .

The path-cam E^2 engages with and acts upon a truck mounted upon a stud set in the side of the lever F^2 , which is pivoted to the stand F^3 secured to the side of the main frame A, and imparts to said lever an intermittent vibratory motion.

The lever F^2 is connected to the three-armed lever K, mounted loosely on the end of the shaft j , by the link or connecting-rod K^1 , and the lever K is connected by the link K^2 to the arm L secured firmly to the end of the rocker-shaft k .

The upper end of the lever K has pivoted thereto the pawl l , which engages with the ratchet-wheel l^1 secured firmly to the shaft j , the form of the cam E^2 and the arrangement of the levers F^2 , K, and L, links or rods K^1 and K^2 , the pawl l , and ratchet-wheel l^1 being such that each revolution of the cam-shaft will impart an intermittent rotary motion to the shaft j , and an intermittent vibratory motion to the shaft k .

The shaft j is mounted in bearings in the supplementary frame M, and has secured thereon in the center between the two side frames, and directly in front of the drill d , the carrier wheel or disk m , the outer edge of which is made of a thickness about equal to the diameter of the rivet to be drilled, and has cut through said thin portion a series of slots or pockets, n , of a shape corresponding to the rivet, as seen in elevation, said pockets being equidistant from each other, and so formed as to receive the rivet with the head toward the axis of the wheel, as shown in Fig. 5.

The shaft j also has secured thereto the wheel or disk N, having formed in its periphery a series of detent-notches, equal in number to the pockets n in the carrier-wheel m , and into one of which is forced, by the action of the face-cam F^1 , the V-shaped point or end of the reciprocating rod N^1 at the completion of each motion of the carrier-wheel m , and serves to correct any irregularity in the motion of the carrier-wheel, and to hold it in place till the clamping-jaws have closed upon the rivet, the detent-rod being forced into the notch by the direct pressure of the cam F^1 after the wheel has completed its motion, and withdrawn again before the wheel commences to move again, by the action of the spring N^2 and the let-off or fall in the cam F^1 , the rod N^1 being made adjustable in length, to compensate for the wear of the parts, by being made in two parts, and a coupling-sleeve, N^3 , connected

thereto by means of right and left hand screw-threads.

This method of correcting and locking the carrier-wheel is a great improvement over the device used in the machine patented by me August 24, 1875, inasmuch as there is less wear to the parts, less friction to resist the movements of the various feeding devices, while a more perfect correction or registration of the carrier-wheel relative to the drill is attainable, from the fact that greater pressure can be brought to bear upon the detent-wheel to turn it when out of place.

O O' are two stands, placed one upon either side of the carrier-wheel, provided with long hubs, through which the shaft j passes, and secured by suitable feet to the cross-tie of the frame M.

The faces of said stands contiguous to the carrier-wheel m are cupped out so as to form a chamber between said two stands, within which the thick portion of the carrier-wheel may revolve, while at the same time said stands bear against the sides of the thin outer edge of said wheel, around the entire circumference of said wheel, to prevent the rivets being displaced from the pockets, except at the points where the rivet is fed into the wheel and discharged therefrom, and at the point where the clamping-jaws seize the rivet to hold it while being drilled.

These stands O O' are provided, on the side facing the drill-spindle, with dovetailed slides to receive the clamping-jaws $g g$, constructed and adapted to engage with the levers J J and be operated thereby, substantially as described in my previous patent cited above, the difference in the two arrangements being that by mounting the jaws $g g$ on the stands O O', instead of on the die-plate secured to the main frame A, as described in my previous patent, the drill and jaws are made much more easily accessible.

The frame M is fitted to and secured upon the front end of the frame A, substantially as described in the patent referred to above.

P is a bifurcated stand, Q an inclined chute, p a curved shield, R a pivoted chute mounted upon the shaft k , and carrying upon its upper side the hopper S, all constructed, arranged, and operating substantially as described in the patent before referred to.

The rivets slide down the inclined chute Q in a single line, with their heads all downward, till the lower rivet drops into the horizontal channel r in front of the plunger r' , by which it is fed into one of the pockets n in the carrier-wheel m .

The plunger r' is formed upon or secured to the front end of the bar o , fitted to move in a dovetailed slide, formed in the upper surface of the shield-stand O', directly over and parallel with the shaft j , said slide being provided with a gib and set-screws, by means of which the friction of said bar o may be regulated.

Directly under the bar o a circular recess

is formed in the shield-stand O' , in which is placed a spiral spring, o^1 , and the follower-disk o^2 , which is pressed upward by the spring o^1 , hard against the under side of the bar o , as shown in Fig. 7, for the purpose of increasing the friction on the bar o , so that it will remain in a state of rest at either extreme of its endwise movement, till moved by the direct application of force thereto.

Upon the upper side of the sliding bar o is secured a supplementary bar, s , held in place by the screws s^1 passing through oblong slots s^2 , and screwed into the bar o in such a manner that the bar s may be moved upon the bar o a short distance in either direction, without affecting the position of the bar o .

A reciprocating motion is imparted to the bar s , and through it to the bar o , by means of the elbow-lever T , pivoted to the frame A at u , one end of which engages with the pin s^3 set in the bar s , and at the other end is pivoted to one end of the connecting-rod U , the opposite end of which is connected to the movable end of the cam-lever U' , to which an intermittent vibratory motion is imparted by the path-cam E^3 .

V is a light lever, pivoted at t to the bar o , and carrying at the end toward the front side of the machine the vertical adjustable pin t^1 , so arranged that when the bars o and s are moved to the extreme of their backward motion said pin will stand directly over the edge of the carrier-wheel, with its center-line coinciding with the center of a pocket therein, with its point or lower end far enough above the same to clear the longest rivet to be drilled.

To the rear end of the lever V is pivoted the link t^2 , which is pivoted at its opposite end to the link t^3 , which is fitted to move up and down between two ears $u^1 u^1$, formed on the rear end of the bar o , the link t^3 being guided in its upward and downward motions by a fulcrum-pin, w^2 , projecting from opposite sides thereof into oblong vertical slots w^3 cut through the ears u^1 , as shown in Figs. 6 and 9.

The link t^3 extends below the pin w^2 , and rests upon the movable end of the spring V^1 , the tension of which tends to hold the pin w^2 hard against the upper ends of the slots w^3 , as shown in Fig. 6.

The rear end of the bar s is connected, by means of the double link v, v , to the central joint of the toggle-links t^2 and t^3 in such a manner that the first part of the forward motion of said bar will tend to straighten the toggle formed by the links t^2 and t^3 , and if there is no impediment in the way of the free descent of the pin t^1 the rear end of the lever V will be raised, causing a corresponding depression of the front end of said lever, the pin t^1 entering the drilled shank of the rivet, held in the pocket of the carrier-wheel, at which time the rear end of the slots s^2 coming in contact with the screws s^1 , a continuation of the movement of the lever T will

cause the bar o , plunger r' , and the lever V to be moved endwise toward the front side of the machine, the pin t^1 discharging the drilled rivet from the pocket of the carrier-wheel into the discharge-chute or channel-way V^2 , extending from the carrier-wheel to the front side of the frame, in line with the channel-way r and the plunger r' , feeding an undrilled rivet into the same pocket, when the forward motion of the lever V and plunger ceases, and they remain in a state of rest till the carrier-wheel has moved about its axis a distance equal to the distance between two pockets, when the motion of the lever T is reversed, the first effect of which is to move the bar s upon the bar o , bend the toggle-joint, and cause the front end of the lever V to be raised, when the bar o and lever V will be moved back to their starting points.

W is the lower arm of the shipper-lever, which controls the belt which imparts motion to the counter-shaft, from which the machine is driven, the upper arm of said lever being broken away.

The extreme lower end of the lever W has secured thereto, or formed thereon, a slightly-projecting tooth, w , which, when the lever W is in position to hold the belt onto the tight pulley on the counter-shaft, (not shown,) engages with the catch w' , projecting upward from the spring V^1 , while the spring W' tends to move the shipper-lever W in the direction to slip the belt onto the loose pulley.

Now, if, when the bar s begins to move toward the front of the machine, there should happen to be an undrilled or an imperfectly-drilled rivet in the pocket of the carrier-wheel, the pin t^1 would be intercepted before completing its downward stroke by coming in contact with the solid metal of the rivet, which, presenting more resistance than the spring V^1 , the power of the toggle-joint would be exerted downward, depressing the spring V^1 , releasing the shipper-lever W from the catch w' , when the tension of the spring W' will move the shipper-lever and throw the belt onto the loose pulley of the counter-shaft, stopping the machine, and ringing the bell X , to call the attention of the operator.

The discharge channel-way V^2 may discharge into the shallow-tray like extension V^3 , the bottom of which is on a level with the bottom of the channel-way at its junction therewith, so that the rivets may be discharged into said tray with their tubular ends upward, or said tray may be dispensed with, and the rivets may fall from the end of the channel-way V^2 into any suitable receptacle placed beneath said channel-way for the purpose.

The channel-way V^2 is provided with a gate, a^2 , to close the entrance thereto held in position with its side in line with the side of the carrier-wheel to prevent the momentum of the plunger r' from throwing the rivet in front of it through the pocket of the carrier-wheel, so far as to present an obstruction to the ro-

tation of said wheel, said gate swinging about its pivot to allow the drilled rivet to be discharged into the channel-way V², and thrown into position again by the spring a³ in time to intercept the solid rivet being fed into the pocket.

To the upper side of the shield-stand O' is secured by means of the screws b² b² passing through slots c³ c³ the bar Y in such a manner that it may be moved endwise in a line parallel to the motion of the plunger r', and having secured to or formed upon its front end the curved finger d¹, having its outer end beveled or wedge shaped, and adapted to move across the upper surface of the inclined chute Q, near its lower end in such a manner as to force the lower rivet in said chute into the channel-way r in front of the plunger r', and retain the other rivets in said chute above said wedge till the plunger r' has passed the mouth of the chute, said finger d¹ and bar Y being moved in one direction by the spring d², and in the opposite direction by the end of the plunger r' coming in contact with the finger d¹.

Z is an oil-tank placed in an elevated position, and provided with a discharge-pipe, e, and cock e¹, by means of which the oil contained in said tank may flow to and be discharged into the funnel e², by which it is directed to the drill.

Z¹ is an oblong tank placed beneath the working parts of the machine with its bottom slightly inclined toward the rear, and supporting therein the shallow tray Z², having its bottom raised some distance above the bottom of Z¹, and inclined toward the front or hopper end of the machine, and a portion of it perforated or made of fine wire netting, so that while the pan Z² will catch and hold the metal chips produced by the drill the oil will flow through its perforated bottom into the receiving-tank Z¹, whence it flows into the secondary receiving-tank Z³ placed at a lower level than Z¹.

A⁴ is an oil-pump, the piston of which is operated by the connecting-rod f¹ and crank-pin f² set in the disk f³, secured upon the end of the driving-shaft C, said pump being adapted to draw oil from the tank Z³, and discharge it through the pipe f⁴ into the elevated tank Z.

B¹ is a lever pivoted to one side of the frame A, and carrying the tappet-rod g¹ adapted to strike the inclined chute Q, when said lever is vibrated to jar said chute and insure the descent of the rivets.

Motion is imparted to the lever B¹ in one direction by the oscillations of the pump connecting-rod f¹, and in the other direction by the spring g².

The driving-pulley D is fitted loosely upon the shaft C, or in such a manner that it may be rotated thereon, and moved along said shaft in the direction of its length, and has formed in one end of its hub the V-shaped radial notch h⁴, which engages with a correspondingly-shaped projection, h⁵, on the con-

tiguous side of the collar C¹, secured upon the shaft C.

The pulley D is forced toward the collar C¹ by the spiral spring i, the tension of which may be increased or diminished at will by means of the nut i¹ and check-nut i².

The pulley D has attached thereto, so as to revolve with it, a spring-pawl, k', adapted to engage with the circumferential groove j³ when the pulley D is moved along the shaft C far enough to disengage the projection h⁵ from the notch h⁴.

B² is a spring secured by one end to the stand C², which supports the rear end of the shaft C, and extending parallel, or nearly so, with the shaft, till its opposite end nearly reaches the web of the pulley D, and has attached thereto the bell D'.

The web of the pulley D has set therein, so as to project therefrom, a pin, j², so arranged relative to the spring B² that when the pulley D is engaged with the shaft C, so as to revolve therewith, said pin will pass the end of said spring without striking it; but when the pulley D is moved along the shaft to disengage it from the collar C¹, the pin j² will strike the end of the spring B² at every revolution of the pulley D and ring the bell D'.

The object of this arrangement of the driving-pulley is to stop the machine whenever, by the breaking of a drill, the disarrangement of a rivet in the carrier-wheel, or other cause, the resistance to the operations of the machine is increased beyond what the tension of the spring i will counteract. Each of the caps of the boxes A³ has formed therein a vertical mortise, in which is placed the Babbitt box A³, and follower-plate l² resting thereon and adapted to be adjusted by the set-screw t³, and having its bearing in the secondary cap l⁴, as shown, to compensate for the wear occasioned by the draft of the belt which drives the spindle.

What I claim as new, and desire to secure by Letters Patent of the United States, is as follows:

1. In combination with the supplementary frame M, movable upon the main frame A, the clamping-jaws g g, mounted upon said supplementary frame M, and adapted to engage with the levers J J when the frame M is secured in position, and to be disengaged therefrom when the frame M is moved back, substantially as and for the purposes described.

2. The combination of the carrier-wheel m, the inclined chute Q, the reciprocating plunger r', and the discharge channel-way V² extending from the carrier-wheel directly opposite the plunger r', substantially as described.

3. The discharge channel-way V², having formed upon its outer end the shallow tray-like extension V³, constructed and arranged substantially as described.

4. The combination of the inclined chute Q, the reciprocating plunger r', and the reciprocating finger d¹, provided with an inclined or

wedge-shaped end, all constructed, arranged, and adapted to operate as and for the purposes described.

5. In combination with the carrier-wheel *m*, adapted to be intermittently rotated about its axis, and an automatically-operated drill, the detent-wheel *N*, the reciprocating rod *N*¹, provided with a *V*-shaped point or end, and the cam *F*¹ and spring *N*², all arranged and adapted to operate substantially as described.

6. The combination of the clamping-levers *J* *J*, having formed in their rear ends rectangular slots extending transversely thereof, the boxes *J*¹ provided with lips and carrying the cam-trucks *h*³, and the adjusting-screws *J*² *J*², all arranged and adapted to operate, as and for the purposes described.

7. The box *J*¹, made in two parts, provided with lips, and bound together and to the lever *J* by the bolt *h*¹, in combination with the adjusting-screw *J*² connected thereto, so as to impart a positive motion to said box in both directions, substantially as described.

8. The combination of the inclined chute *Q*, the feed-plunger *r*¹, adapted to take a rivet from the foot of the chute and feed it to the carrier-wheel, the lever *T*, connecting-rod *U*, cam-lever *U*¹, and the path-cam *E*³, all adapted to impart to said plunger a positive motion in both directions, substantially as described.

9. In combination with an automatically-operated drill, an intermittently-rotating carrier-wheel and a pair of clamping-jaws, adapted to seize and hold the rivet while it is being drilled, an elevated oil-tank, a suitable discharge-pipe provided with a cock to regulate the flow of oil and a funnel to receive the oil and direct it upon the drill, substantially as described.

10. The combination, in a drilling-machine, of the elevated oil-supply tank *Z*, the receiving-tank *Z*¹, the secondary tank *Z*³, and the pump *A*⁴, adapted to draft from the secondary tank *Z*³ and discharge into the supply-tank *Z*, substantially as described.

11. In combination with an intermittently-operated carrier-wheel, provided with a series of pockets, each adapted to receive and carry a rivet to the drilling-tool, an inclined chute, and a reciprocating plunger, adapted to feed the rivets successively from the foot of the chute to the pockets in the carrier-wheel, the lever *V*, pivoted to the plunger-carrier, and carrying at one end the testing-pin *t*¹, and connected at its other end with a toggle having no fixed fulcrum, and the bar *s*, movably attached to the plunger-carrier, and connected to the center of the toggle, all arranged and adapted to operate substantially as described.

12. The combination of the carrier-wheel *m*, inclined chute *Q*, plunger *r*¹, lever *V*, testing-pin *t*¹, a toggle having no fixed fulcrum, and adapted to impart motion in either of two opposite directions, the reciprocating bar *s*,

the spring *V*¹, provided with the catch *w*¹, and the shipper-lever *W*, adapted to engage with the catch *w*¹, and be held thereby against the tension of the spring *W*¹, substantially as and for the purposes described.

13. In combination with the shipper-lever *W*, held in position by the spring *V*¹ and catch *w*¹, and the spring *W*¹, adapted to move the lever *W* away from the catch *w*¹ when the spring *V*¹ is depressed, the bell *X*, flexibly connected to the shipper-lever, substantially as shown and described.

14. The combination of the carrier-wheel *m*, the inclined chute *Q*, the feed-plunger *r*¹, the lever *V*, provided with the testing-pin *t*¹, the discharge channel-way *V*², and the spring-operated gate *a*², all arranged and adapted to operate as and for the purposes described.

15. The combination of the pulley *D*, provided with the beveled-sided notch *h*⁴ in the end of its hub, and mounted loosely upon the shaft *C*, so that it may be revolved or moved endwise thereon, the collar *C*¹, secured to the shaft *C*, and having formed upon its radial face, contiguous to the hub of the pulley *D*, the bevel-sided tooth *h*⁵, and the spring *i*, all arranged and adapted to operate as and for the purposes described.

16. The combination of the pulley *D*, provided with notch *h*⁴, and mounted loosely upon the shaft *C*, the spring *i*, the collar *C*¹, provided with the tooth *h*⁵ and the circumferential groove *i*³, and the spring-actuated pawl *k*¹, all arranged and adapted to operate as and for the purposes described.

17. In combination with a driving-pulley adapted to be engaged with its shaft by being moved lengthwise of said shaft by the pressure of a spring, and to be disengaged therefrom by an increase of resistance to the revolution of said shaft, the spring *B*², having secured thereto or otherwise connected therewith the bell *D*¹, and the pin *j*², projecting from and revolving with the pulley *D*, all arranged and adapted to operate as and for the purposes described.

18. In combination with the rotating and reciprocating drill-spindle *G*, the Babbitt metal half-boxes *A*³, fitted to and movable in mortises made through the caps of the spindle-bearings, the follower-plates *l*², and the set-screws *l*³, having their bearings in the secondary caps *l*⁴, substantially as described.

19. The stand *H*², provided with the groove or slide in its upper surface, in combination with the yoke *H* *H*¹, provided with the tongue fitted to and adapted to reciprocate in the groove, substantially as and for the purposes described.

Executed at Boston, Massachusetts, this 29th day of September, 1876.

MELLEN BRAY.

Witnesses:

N. C. LOMBARD,

E. A. HEMMENWAY.