

W. T. BURROWS.

WIND-MILL

No. 188,853.

Patented March 27, 1877.

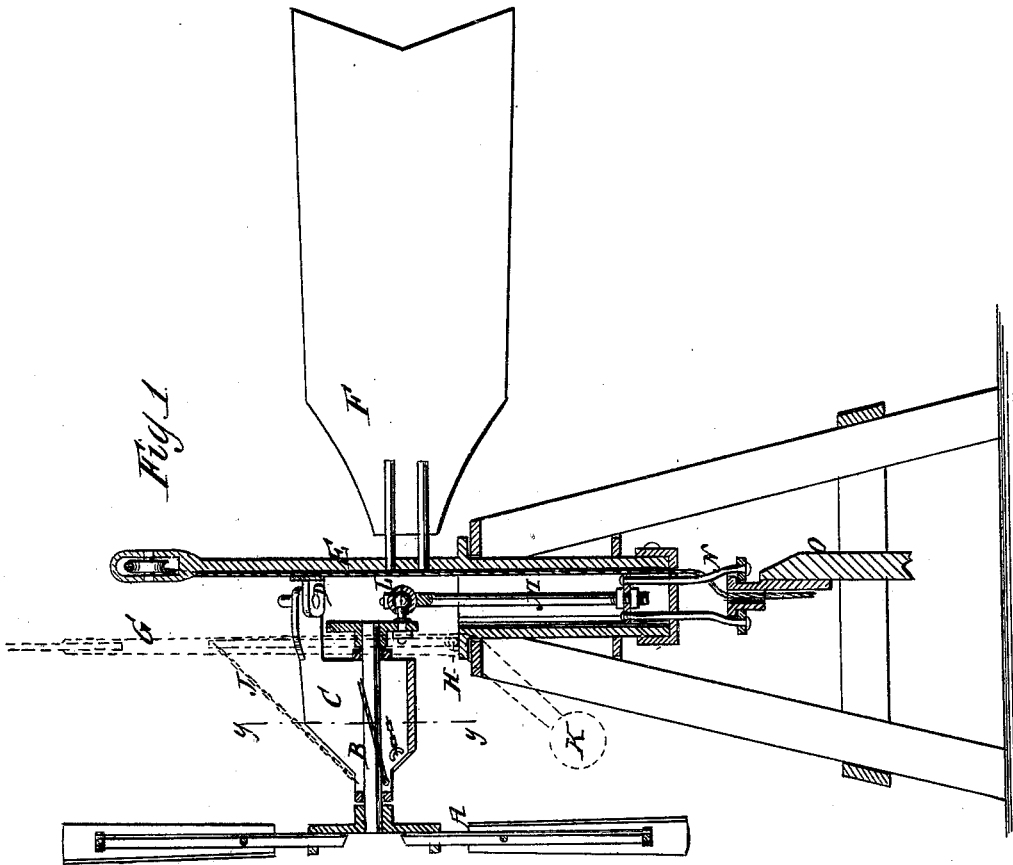
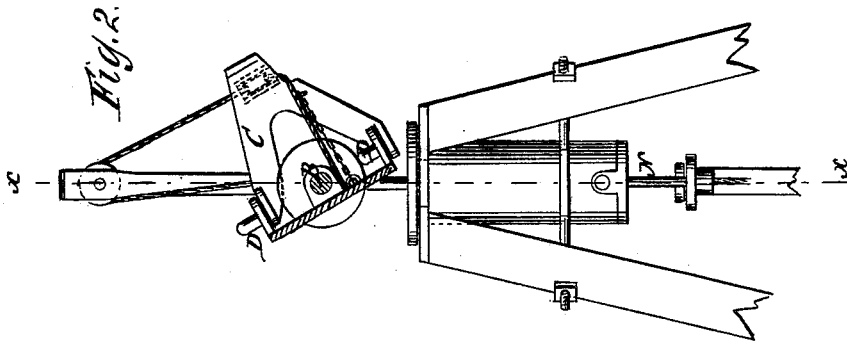

WITNESSES:

*E. Wolff.*  
*John Goethals.*

INVENTOR:

*W. T. Burrows*

BY

*Wm. H. ...*

ATTORNEYS.

# UNITED STATES PATENT OFFICE

WILLIAM T. BURROWS, OF NASHUA, IOWA.

## IMPROVEMENT IN WINDMILLS.

Specification forming part of Letters Patent No. **188,852**, dated March 27, 1877; application filed May 1, 1876.

*To all whom it may concern:*

Be it known that I, WILLIAM T. BURROWS, of Nashua, in the county of Chickasaw and State of Iowa, have invented a new and Improved Windmill, of which the following is a specification:

This improvement consists of the shaft of the wind-wheel so pivoted to the head of the tail-vane that, in turning out of the wind under the influence of great force, the wheel will swing up an incline, whereby its own tendency to swing back down the incline is the means of keeping the wheel in the wind; and, in combination with a wheel in this arrangement, I propose to arrange a vertical vane behind the wheel on a pivoted bar, and connected to the vibrating wheel-frame, to pull the wheel up the incline, in order that it will swing out of the wind more easily, and the lever of this vane will be weighted to regulate its action, to accommodate the wheel in so swinging out of the wind. The crank is connected to the pump-rod by a ball-and-socket joint.

Figure 1 is a sectional elevation of my improved windmill, taken on the line *x x*, Fig. 2. Fig. 2 is a section on line *y y*, Fig. 1.

A is the wheel, and B the shaft, which are mounted on the plate or frame C, which is pivoted at D to the tail-vane support E, on an axis inclined to the vertical line, so that in swinging around on said axis parallel to the

vane F, for stopping and for being relieved of the wind when blowing too strong, it will rise up an incline of twenty degrees, or more, which makes the resistance that is to keep the wheel in the wind; but, in case of necessity for stationary wheel to turn it out of the wind, I propose to have a tail-vane, G, fixed behind the wheel, broadside to the wind, on a pivot, H, and connected to the frame C by a chain, J, said vane having a weighted arm, K, to hold it to the wind until the force becomes so great as to require the wheel to turn, when, by swinging back a little, it will start the wheel out of the direct line of the wind, after which the wheel will be turned by the wind. L is the ball-and-socket joint, by which the rod M is connected to allow the wheel to swing up the incline. N is a swivel, by which the connecting-rod M is coupled to the pump-rod O.

Having thus described my invention, what I claim as new, and desire to secure by Letters Patent, is—

The combination, with frame C, pivoted to tail-vane support E, and arranged on an inclined shaft, of the tail-vane G, pivoted at H, and connected by chain with said frame C, substantially as and for the purpose specified.

WILLIAM TURNER BURROWS.

Witnesses:

H. H. HOPKINS,  
H. I. HOLCOMBE.