

W. H. EWING.

MACHINE FOR SETTING UP BARRELS.

No. 188,880.

Patented March 27, 1877.

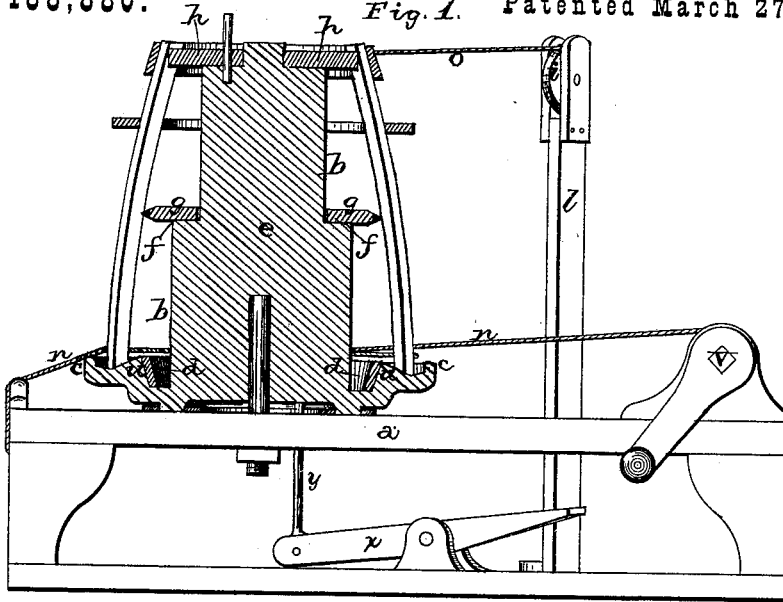

Fig. 2.

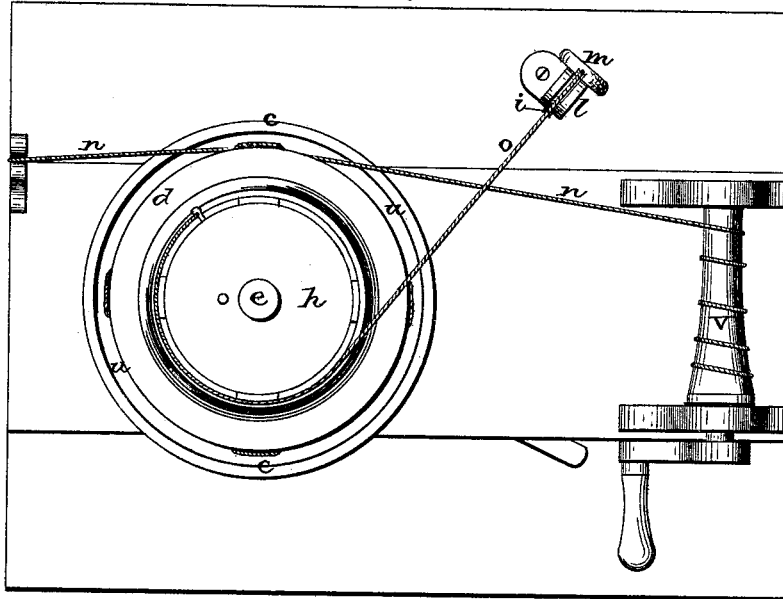

Fig. 3.

WITNESSES:

J. W. Garner,
J. H. Burnham,



INVENTOR
Wm. H. Ewing
per
F. A. Lehmann, Atty.

UNITED STATES PATENT OFFICE.

WILLIAM H. EWING, OF PITTSBURG, PENNSYLVANIA.

IMPROVEMENT IN MACHINES FOR SETTING UP BARRELS.

Specification forming part of Letters Patent No. 188,880, dated March 27, 1877; application filed January 15, 1877.

CASE B.

To all whom it may concern:

Be it known that I, WM. H. EWING, of Pittsburg, in the county of Allegheny and State of Pennsylvania, have invented certain new and useful Improvements in Machines for Setting Up Barrels; and I do hereby declare the following to be a full, clear, and exact description of the invention, such as will enable others skilled in the art to which it pertains to make and use it, reference being had to the accompanying drawings, which form part of this specification.

My invention relates to an improvement in machines for setting up kegs, barrels, &c.; and it consists in a revolving form on which the staves are placed, and the arrangement and combination of devices used in connection therewith, that will be more fully explained hereinafter.

Figure 1 is a side elevation of my invention. Fig. 2 is a plan view of the same. Fig. 3 is a detailed view.

a represents a suitable bed or frame, up from or through which projects a vertical spindle, upon and around which the form *b* revolves. The outer edge of this form has a flange, *c*, all around it, which serves to prevent the staves from slipping off after they have been placed in position. From this flange the bottom of the form slants downward for a short distance, and then rises upward to the edge of the recess *d*, which is made in the bottom of the form all around the center-post *e*, to hold the bottom truss-hoop. About half way up the post there is a shoulder, *f*, made, which serves as a support for the circular pieces *g*, having rubber edges on their outer sides.

These pieces are used in shaping the keg or barrel, and are preferably provided with rubber, so that there may be a slight resistance at this point to the pressure of the staves to force them into proper shape.

The post is considerably smaller above the shoulder, so as to allow free room for the operator's hands between the post and staves.

Upon the top of the post is placed the disk *h*, which is made just the size of the head of the keg or barrel that is being made, and which serves as a guide or support for the upper ends of the staves to rest against. This

disk is kept from turning around by means of a pin or any suitable stop; but can be raised vertically with the keg in case the staves should clamp it too tightly, when it can be readily pushed out.

The staves are held in position as they are being set up by a cord, rope, or chain fastened by a pin to the lower side of the disk, and passing outward over a pulley, *i*, placed in the top of the post *l*, with a weight, *m*, secured to its outer end, lapping around them as each succeeding stave is placed in position.

The weight attached to the outer end of this rope should be sufficiently heavy to hold each stave securely in its place without being heavy enough to pull the form backward when released.

After the staves are all set up, the end truss-hoop is driven on, and the former is turned backward till the rope holding the staves in position is run off. The bilge-hoop is then put on and driven down to near the center of the keg. The windlass-rope *n*, which has one end fastened to the frame, and the other passed around the windlass *v*, is then formed into a loop and thrown over the keg, dropping down to near the lower end of the staves. It is then wound onto the windlass, drawing the staves together at the bottom, and forcing the keg up the inclined bottom till it comes directly over the recess *d*, when it drops into the end truss-hoop *w*, placed in the recess to receive that end of the keg. The windlass is then let go, the rope thrown off, and the keg, with the truss-hoop on its lower end, is lifted out and the circular pieces *g* removed from the inside, and the keg or barrel is ready for the trussing and finishing process.

In case the keg should not fall into the truss-hoop lying in the recess, the operator places his foot on the treadle *x*, which causes the rod *y* to raise the former upward and allows it to drop suddenly, jarring the keg into the truss-hoop.

The windlass may be operated either by hand or steam power.

The advantage of this windlass is, that a keg or barrel can never be windlashed more than is necessary, thereby obviating breaking of staves.

This invention is an improvement upon an-

other machine for the same purpose, for which I have also applied for a patent on the 15th day of January, 1877, marked "Case A."

Having thus described my invention, I claim—

1. In a machine for setting up staves, a horizontally-revolving former, which is provided with a recess for receiving the ends of the staves, and a second interior recess for receiving a truss, substantially as shown.

2. The combination, with a former, of an agitator for shaking down the staves into the truss, substantially as described.

3. A horizontally-revolving former having

a flange, *c*, a place inside of the flange upon which to set the ends of the staves, and a recess to receive the truss, in combination with a windlass for drawing the ends of the staves into the truss, in the manner shown and described.

In testimony that I claim the foregoing I have hereunto set my hand this 12th day of January, 1877.

WM. H. EWING.

Witnesses:

F. A. LEHMANN,
R. M. BARR.