

J. G. HOBERT.  
VAPOR-BURNER.

No. 188,906.

Patented March 27, 1877.

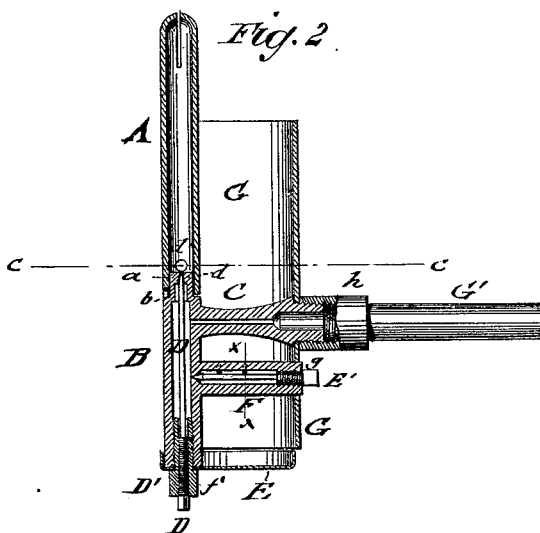
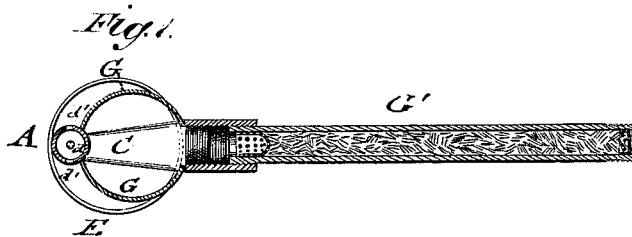

Fig. 3.

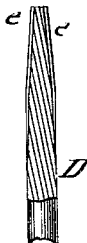

Fig. 4.



WITNESSES:

*Francis M. Child.*  
*J. H. Scarborough*

Fig. 5.



INVENTOR:

*J. G. Hobert*

BY

*Mumford*

ATTORNEYS.

# UNITED STATES PATENT OFFICE

JONAS G. HOBERT, OF SYRACUSE, NEW YORK.

## IMPROVEMENT IN VAPOR-BURNERS.

Specification forming part of Letters Patent No. **188,906**, dated March 13, 1877; application filed November 18, 1876.

*To all whom it may concern:*

Be it known that I, JONAS G. HOBERT, of Syracuse, in the county of Onondaga and State of New York, have invented a new and Improved Vapor-Burner, of which the following is a specification:

In the accompanying drawing, Figure 1 represents a horizontal section of my improved vapor-burner on line *c c*, Fig. 2; Fig. 2, a vertical central section of the same; Fig. 3, a detail section of the stem of the supply-valve; Fig. 4, a detail vertical transverse section on line *x x*, Fig. 2, of the heating-tube; and Fig. 5, a top view of the supply-valve.

Similar letters of reference indicate corresponding parts.

This invention relates to an improved vapor-burner for gasoline and other light hydrocarbons, which gives an effective light, is readily cleaned and adjusted, and very economical in use.

The invention consists of a vapor-burner, arranged with a notched or grooved stem of the supply-valve, that may be readily removed for being cleaned of gummy sediments; also of a heating-tube with regulating-valve, a detachable shield or inclosing tube for admitting the cleaning of the heating and main tubes, and of an alcohol-dish, secured vertically below, and centrally to, the axis of the shield.

In the drawing, A represents the upper detachable burner-tube, and B the lower burner-tube, to which gasoline or any other light hydrocarbon is supplied by a conducting main tube, C, placed at right angles to the lower burner-tube. The upper burner-tube A is fitted to a seat, *a*, of the lower tube B, and is retained, by a recess and lip, *b*, in position thereon. The gasoline vapors enter to the upper burner-tube through a small aperture, *d*, of the lower tube B, and mingle with atmospheric air entering through side holes *d'*, so as to be fully burned up. The exit-aperture *d* is kept clean by means of a valve-stem, D, with tapering and channeled or grooved end, that fits into aperture *d*, and admits the passage of the vapors through the channels or grooves *e* of the stem, as shown in detail in Fig. 5. The lower part of the valve-stem D is secured to a screw-plug, D', that screws into the bottom part of the lower burner-tube. The screw-

plug D' serves also to secure, by means of a collar, *f*, the alcohol-dish E into position.

The grooves of the conical valve-stem are intended to give direction to the flow of gas, so that it will go directly up to the aperture of the burner-tube without striking the sides of the tube, thus producing a direct, free, and forcible exit, and giving a stronger and better light than when the current of gas impinges against the inside of the tube and causes eddies in the current.

The grooves, which are arranged in pairs—two, four, or more—are placed directly opposite each other, so that when the currents meet they will counteract upon each other, and thus tend in upward direction.

The grooves are intended to be made of proper size to admit the flow of just sufficient gas to give a flame of certain size, when the valve is snugly screwed into its place in the seat *a*. This enables an unskilled person to take it out and clean it when necessary, and put it back to its proper place by screwing it to its seat.

The burner is readily cleaned by detaching the stem D, and clearing the same of any adhering gummy sediments or dirt. The supply-aperture is thus, by means of the stem, prevented from choking without introducing a pin or tool, and enlarging thereby the supply-aperture, so as to spoil the burner and necessitate the repairing of the same.

The liquid-supply tube C is flattened at the top and bottom, for being more fully exposed to the heating side jets of a tube, F, arranged below the supply-tube, at right angles to the lower burner-section. The heating tube F communicates by a conical aperture with the lower part B of the burner, which aperture is opened or closed by the conical end of a stem-valve, E', that is adjusted by a screw-plug, *g*, in the outer end of the heating-tube.

The supply of vapors to the heating-tube may be regulated, increased, or interrupted by the stem-valve E', which furnishes a reliable device for controlling the light of the vapor-burner. The gas-jets issue through side apertures of the heating-tube, and heat the supply-tube, so as to change the gasoline into vapors.

For lighting the burner, the heating-tube is

first heated up by the alcohol-dish E, which is secured vertically below the inclosing shield or tube G, and nearly centrally to the axis of the same.

The diameter of the alcohol-dish is about equal to that of the shield G, which produces a more finished appearance of the burner, as the alcohol-dish looks like a cap at the lower part of the same.

The entire heating capacity of the alcohol is, by this arrangement of the dish, thrown on the supply-tube C, so as to produce the gasoline vapors, and light the same when they issue from the holes of the heating-tube. The vapor-jets heat then the supply-tube, admitting thus the lighting of the burner in quicker manner than heretofore, where the alcohol-dish has been placed more or less outside of the shield.

The shield G is secured, in detachable manner, to the burner and supply tubes by being fitted at the open side exactly to the burner-tubes A B, and by holes to the supply and heating tubes. It is tightly fastened in position by a binding-screw sleeve, *h*, of the conducting-tube G', which may be provided with suitable strainers and absorbents for admitting only the passage of pure gasoline.

By unscrewing the binding-sleeve, and removing the burner from the conducting-tube, the shield may be readily detached, and thereby the heating and supply tubes conveniently cleaned of all impurities. This forms an im-

portant feature of my burner, as thereby every part of it may be fully brought within view for cleaning and repairing, if necessary.

The main advantage of the burner consists, therefore, in the ready access to, and cleaning of, the different parts, in the time gained in lighting the same, which is of considerable importance in street and other lamps, and in the saving of gasoline obtained in the heating of the supply-tube by the direct connection of the heating-tube with the lower burner-tube.

Having thus described my invention, I claim as new and desire to secure by Letters Patent—

1. The combination of the exit-aperture of a vapor-burner with a grooved or channeled and conical valve-stem, substantially as and for the purpose set forth.

2. The combination of the lower burner-tube with a screw-plug having an enlarged shoulder or collar, and an alcohol-dish placed vertically below the inclosing tube or shield of the burner, substantially as specified.

3. The combination of the flattened supply-tube and lower burner-tube with a heating-tube, placed vertically below the supply-tube, and having an adjustable stem-valve for regulating the gas-jets of the heating-tube, substantially as specified.

JONAS G. HOBERT.

Witnesses:

PAUL GOEPEL,  
C. SEDGWICK.