

H. STRIEWIG.  
CORN-PLANTER.

No. 188,980.

Patented March 27, 1877.

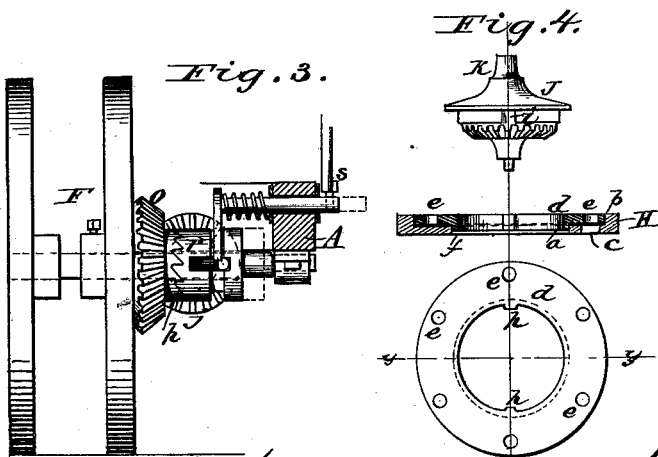
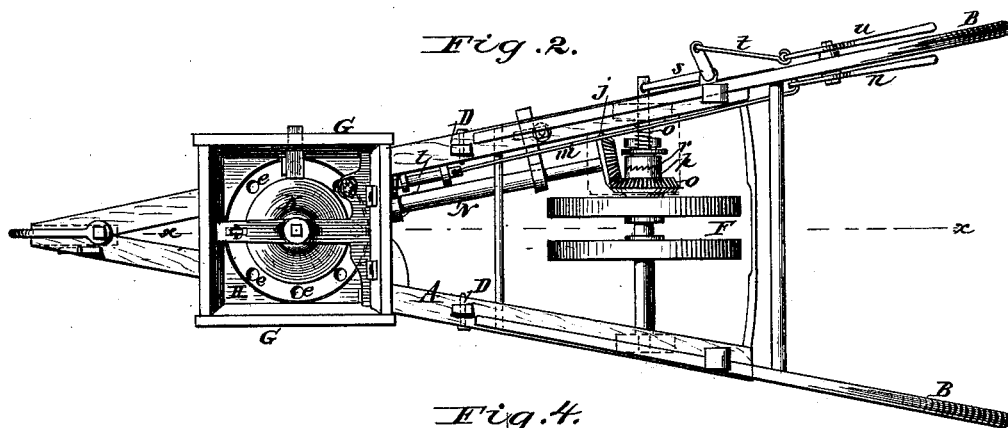
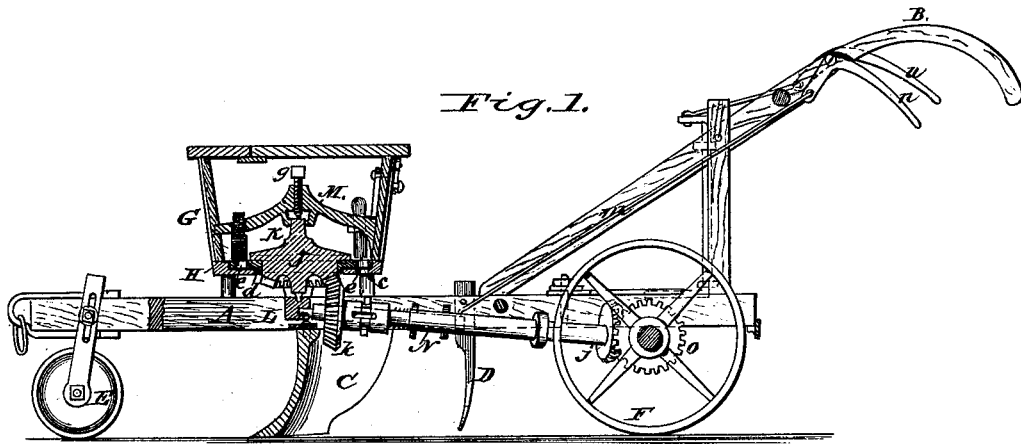

Attest  
J. D. Perrine  
Jm. D. Vallent.

Inventor.  
Henry Striewig,  
By. Wm. H. Finckel  
Attorney.

# UNITED STATES PATENT OFFICE.

HENRY STRIEWIG, OF YORK, PENNSYLVANIA.

## IMPROVEMENT IN CORN-PLANTERS.

Specification forming part of Letters Patent No. 188,980, dated March 27, 1877; application filed December 28, 1876.

*To all whom it may concern:*

Be it known that I, HENRY STRIEWIG, of York, in the county of York and State of Pennsylvania, have invented certain new and useful Improvements in Corn-Planters, of which the following is a full, clear, and exact description.

My invention relates to means for adjusting the dropping mechanism of a corn-planter; and the invention consists in combining, with a rotating dropping-plate in the hopper, a set-screw, by adjusting which the wear occasioned by the rotation of the said plate is compensated for, and any looseness of parts corrected, the construction, combination, and arrangement being substantially as hereinafter specified.

In the drawings illustrating my invention, Figure 1 is a sectional elevation; Fig. 2, a top-plan view; Fig. 3, an elevation of the rear clutch mechanism. Fig. 4 shows the hopper-gear, bed, and feed-plate.

The letter A designates a frame of suitable construction, having handles B B, a furrow-opener, C, and teeth D D; a gage-wheel, E, and driving-wheels F, one or more which latter are keyed to a shaft having bearings on the frame. G is the hopper, constructed with a metal or other bottom, H, and suitable cover. This bottom H is made with a central circular opening, *a*, surrounding which, on the upper face of the bottom, is a depression or recess, *b*, and just above the furrow-opener C, and through the recessed portion *b* of the bottom or bed H, is made the seed-opening *c*. Upon the bed H, and within the recess *b*, rests the plate *d*, having seed-openings *e* therein, which register with the opening *c* in the bottom or bed. This plate *d* is made with a downwardly-projecting flange, *f*, that fits within the opening *a* in the bed, and forms, as it were, a hub for the plate to turn upon, the said plate being annular, and rotated as will be explained. J is a beveled cog-wheel, having a vertical shaft, K, the lower end whereof is seated in a suitably-constructed cross-bar, L, beneath the hopper, and its upper end received in a socketed spider, M, within the hopper. *g* is a set-screw passing through the head of the socket of spider M, and bearing upon the upper end of the shaft K. This cog-wheel J turns with-

in the hub of the plate *d*, and is fixed or connected thereto by any suitable means, as feathers *h*, entering notches or seats *i*, so that said plate and cog-wheel shall rotate together. The spider M has secured to it, if desired, the usual brushes, &c., used to keep the seed-orifices of the plate clear. N is a shaft held in suitable hangers or bearings on the frame, and extending from the driving-wheel, where its end is provided with a beveled gear, *j*, to the hopper, at which end it is fitted with a gear, *k*, that meshes with the cog-wheel J to impart motion thereto, and to the feed-plate *d*.

In order to provide means for stopping the rotation of the feed-plate while the machine is moving, I construct the gear *k* with a sleeve, and fit it so as to slide on the end of the shaft N, a spring-clutch, *l*, being connected with said gear's sleeve, and having a rod, *m*, extending thence to a crank-lever or hand-gripe, *n*, on the handle B, which is thus within reach of the operator, and whereby said operator can throw the wheels J *k* out of gear. By releasing the lever *n* the spring-clutch automatically throws the wheels into gear. Instead of this, the gear *o* on the driving-wheel shaft, which meshes with the gear *j* on shaft N, may be loosely arranged on said shaft, and be provided with a serrated sleeve, *p*. A male serrated sleeve, *r*, sliding on the driving-wheel shaft in line with gear *o*, is thrown in and out of gear with said gear *o* by means of a spring-clutch mechanism, O. This mechanism may be brought within reach of the user of the planter by a double crank, *s*, rod *t*, and lever *u*, arranged substantially as shown, or by means of other suitable connections.

If a fertilizer-distributor be arranged in this planter, this last-described clutch mechanism may be used in connection with it, and the other in connection with the grain-feed.

It will be noticed that in both these instances of clutch mechanism, the shaft N is not movable, being fixed to revolve in stationary bearings, but the gears thereon are movable for engagement with and disengagement from the feed-plate to be operated.

In operation, the feed-plate serves to carry the corn to the orifice *c*, whence it drops through the furrow-opener into the furrow, the shaft N serving to transmit rotary motion

to it through its cog-wheel and shaft. By the long-continued rotation of the feed-plate it and its seat or bed become worn, and hence it fits loosely therein, which evil soon becomes a serious one, and to remedy it the set-screw *g* is provided, the adjustment of which, relatively to the shaft of the cog-wheel, serving to tighten the plate in its seat, and thus overcome all looseness.

What I claim is—

The socketed spider M, adjusting-screw *g*, passing through the socketed portion of said

spider, the cog-wheel J, the shaft K, the upper end of which rests in the socket of said spider M, the feed plate *d*, bed H, recessed and made annular to receive said plate, the hopper G, and operating mechanism, constructed, combined, and arranged substantially as shown and described.

HENRY STRIEWIG.

Witnesses:

GEORGE M. SHETTER,  
JACOB W. SPANGLER.