

F. N. DAVIS.
PAPER-BARREL MACHINE.

No. 189,024.

Patented April 3, 1877.

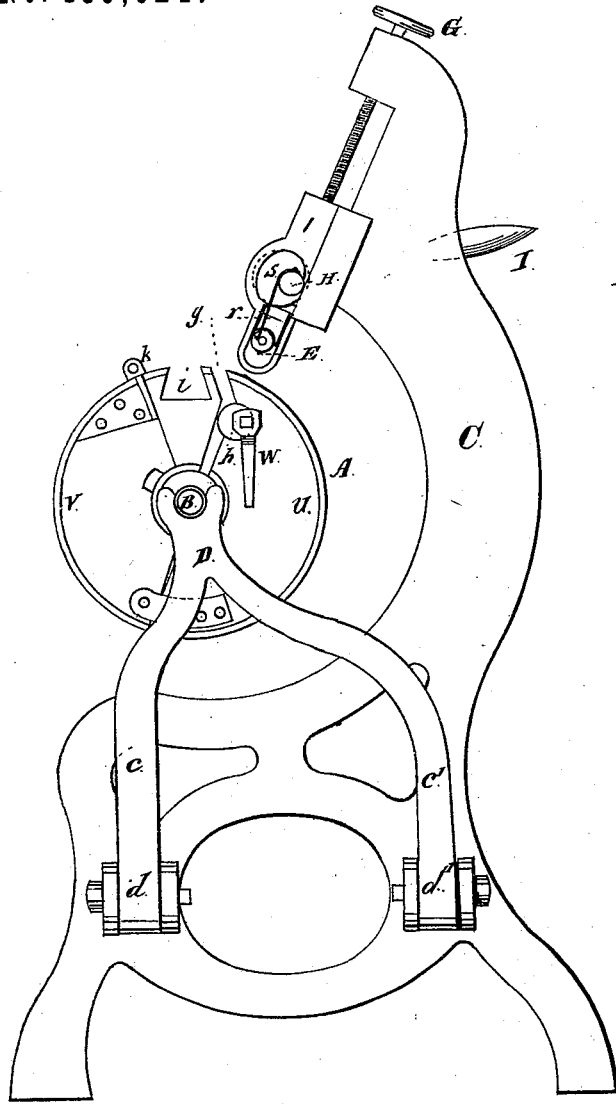

Fig. 1.

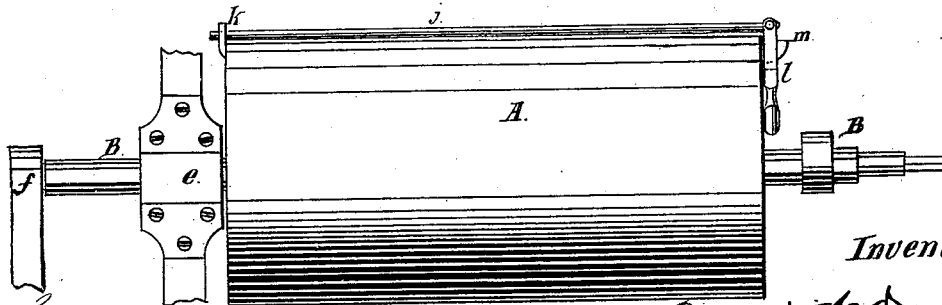

Fig. 2.

Witnesses:
Heinrich J. Bruns
W. Bond.

Inventor:
Francis N. Davis

F. N. DAVIS.
PAPER-BARREL MACHINE.

No. 189,024.

Patented April 3, 1877.

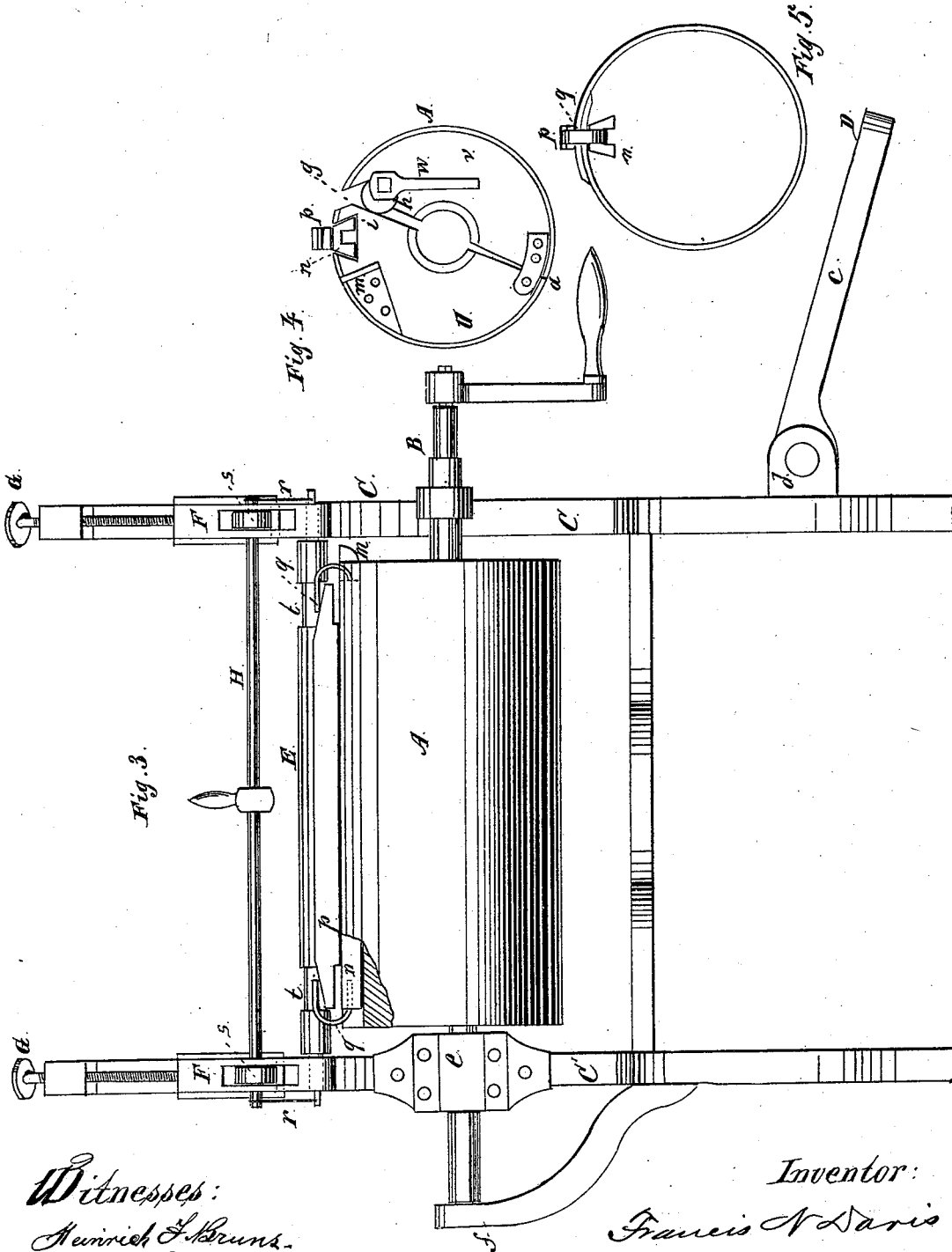

Witnesses:
Heinrich L. Bruns.
O. W. Bond

Inventor:
Francis N. Davis

UNITED STATES PATENT OFFICE.

FRANCIS N. DAVIS, OF BELOIT, WISCONSIN.

IMPROVEMENT IN PAPER-BARREL MACHINES.

Specification forming part of Letters Patent No. 159,024, dated April 3, 1877; application filed September 19, 1876.

To all whom it may concern:

Be it known that I, FRANCIS N. DAVIS, of Beloit, in the county of Rock and State of Wisconsin, have invented certain new and useful Improvements in Paper-Barrel Machinery; and I do hereby declare that the following is a full, clear, and exact description thereof, that will enable others skilled in the art to which it appertains to make and use the same, reference being had to the accompanying drawings, and to the letters of reference marked thereon, which form a part of this specification.

Referring to the drawings, Figure 1 is an end elevation; Fig. 2, a front elevation of the cylinder with the device for clamping one end of the sheet to the cylinder; Fig. 3, a front elevation, showing the devices for regulating the pressure upon the sheet while it is being formed, also devices for clamping the two ends of the sheet together, also showing one of the bearings of the shaft of the cylinder turned down; Fig. 4, an end view of the cylinder, also showing the position of the two clamping-bars—the clamp itself not being represented; Fig. 5, an end view of the body, with the clamps thereon, removed from the machine.

It is customary to make the body of a paper barrel from a single heavy sheet of paper board, the ends of which must, in some way, be properly secured together. I have found the methods in use for doing this objectionable.

The object of my invention is to provide means, by the use of which the ends can be secured together by a glue-joint; and this I accomplish by means of an expanding cylinder, one end of the shaft of which is supported in a movable bearing, so that, after the sheet has been wound upon the cylinder and the ends secured, it can be immediately removed from the cylinder without waiting for the joint to dry, by the use of suitable clamping devices, and by the use of suitable devices for adjusting the pressure upon the sheet while it is being wound upon the cylinder.

In the drawings, A represents an expanding cylinder made in two parts, *u v*, hinged one to the other at *a*.

B is the shaft of the cylinder. It is permanently secured to one part, *u*, of the cylinder.

C C' are the standards or end pieces of the frame. The form of the standard C is shown in Fig. 1. No part of it comes forward far enough to project over any portion of the cylinder, the object being to leave an open space for the removal of the body of the barrel after its ends have been joined.

D is the bearing for one end of the shaft B. It is open at the top, and connected with it are two arms, *c c'*, which are hinged to C at *d d'*. The other end of this shaft is supported in a bearing, *e*. This shaft, however, is extended out some way beyond the frame, and the extreme end thereof revolves in a support or bearing, *f*, so that this end of the shaft has two points of support, by means of which the cylinder will be supported when the bearing D is turned down, as shown in Fig. 3.

The cylinder can be expanded at the joint *g* by means of the cams *h* upon a secondary shaft extending through one part of the cylinder, the cams coming in contact with suitable faces upon the other half of the cylinder. *w* is a lever or crank for operating the shaft upon which the cams *h* are located.

i is a dovetailed groove through the part *v* of the cylinder. It is located very near the opening *g*.

j is a removable clamping-bar, one end of which, as shown, is inserted into a hole in *k*, which is secured to one end of the cylinder. Upon one end of this clamping-bar *j* is hinged an arm, *l*, which is provided with a slot to engage with the projection *m* on the cylinder.

n is a clamping-bar, adapted to slide easily into the dovetail recess *i*. Each end of this bar is recessed, as shown in Fig. 4.

p is another clamping-bar, the ends of which are cut away upon the under side, as shown in Fig. 3.

q are clamping-irons, adapted to be driven over the ends of the two bars *n p*.

Various devices may be used for adjusting the pressure upon the sheet while it is being wound upon the cylinder. I have represented the following:

E is a roller supported in bearings F, which bearings can be adjusted vertically upon the

frame by means of the screws G G. This roller E is so arranged that it can be moved up and down.

H is a shaft having an eccentric or cam, *s*, upon each end. It also is supported in the bearings F. E and H, as shown, are connected together at each end by means of a cord, *r*.

I is a handle or lever for operating the shaft H.

The roller E is provided with a recess, *t*, near each end, for guiding the end hoops.

In use, the ends of the sheet which is to form the body of the barrel are chamfered, the sheet being of such length that one end will lap over the other, about.

I then secure a wooden hoop to each end of the sheet by means of tacks.

The clamping-bar *n* is placed in the dovetail groove *i* of the cylinder. One end of the sheet is placed over the clamping-bar *n*, and secured in place by means of the clamp *j*. The cylinder is to be expanded by means of the cams *h*, operated by the crank *w*; then by rotating the cylinder the sheet will pass under the roller E, the hoops passing in the recesses *t*, and the roller E being properly adjusted, the sheet will be held in close contact with the cylinder, and be tightly wound thereon. Before a revolution is entirely complete glue is to be applied to the surfaces of the two ends of the sheet which are to come in contact; then the bar *p* is to be placed upon the top of the sheet. The two ends are to be brought together, and the clamping-irons *q* are to be applied to each end of the clamping-bars, and driven to place. The two ends of the sheet will then be firmly held together between these bars *n p*; then by turning the cams *h* the two parts of the cylinder will come together, making the cylinder somewhat

smaller than before; then the bar *j* is to be removed; then the body of the barrel, with the clamps, can be removed by sliding the same from the cylinder, first turning down the bearing D, as represented in Fig. 3. The cylinder will be suitably supported while the body is being removed by means of the two bearings *e* and *f* for the shaft B.

The body thus removed, with the clamps thereon, can be set aside, as long as will be necessary for the glue to set.

By the use of a number of clamping-bars and clamps the work can go on continuously, only a single cylinder being used. If a cylinder had to be prepared for each body the expense would be too great.

Cylinders of different sizes can be used in the same machine.

The clamping-bars *n p* may be made of wood.

What I claim as new, and desire to secure by Letters Patent, is as follows:

1. The roller A, constructed in two parts, hinged together at one side, one section having a dovetailed groove, *i*, in combination with the eccentric *h*, for expanding or contracting the cylinder, so as to enable the shells to be easily withdrawn with their clamps, substantially as specified.

2. The locking-rod *j* and lock *l m*, in combination with the removable clamp *n p*, and roller A, substantially as set forth.

3. The combination of the sliding heads F, frame C, screws G, roller E, eccentric *s*, shaft H, and roller A, for adjusting space and pressure, substantially as described.

FRANCIS N. DAVIS.

Witnesses:

O. W. BOND,
H. F. BRUNS.