

J. M. LAUGHLIN.

MACHINE FOR MAKING HORSESHOE NAILS.

No. 189,108.

Patented April 3, 1877.

Fig. 2.

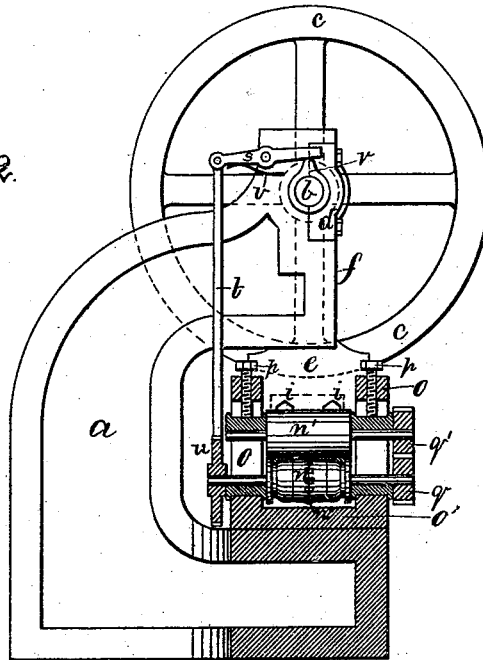
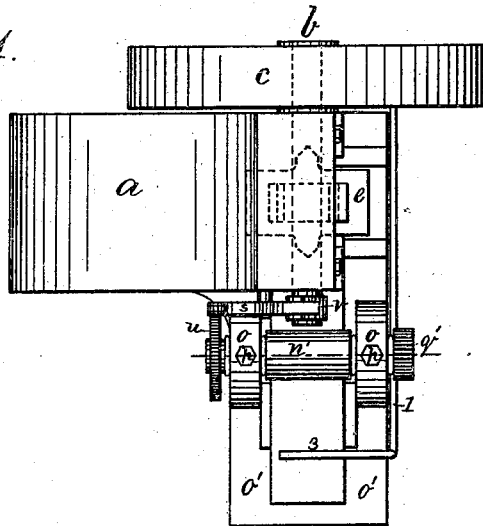

Fig. 1.



Witnesses:

Henry Chadbourn
H. Allen.

Inventor:

Joseph M. Laughlin.
by
Wm. Andren.
his atty.

J. M. LAUGHLIN.

MACHINE FOR MAKING HORSESHOE NAILS.

No. 189,108.

Patented April 3, 1877.

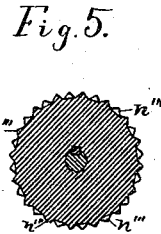
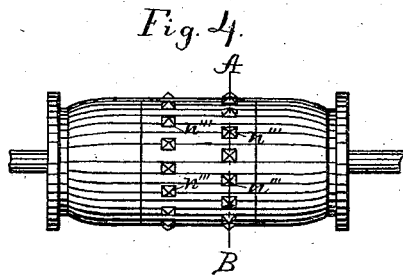
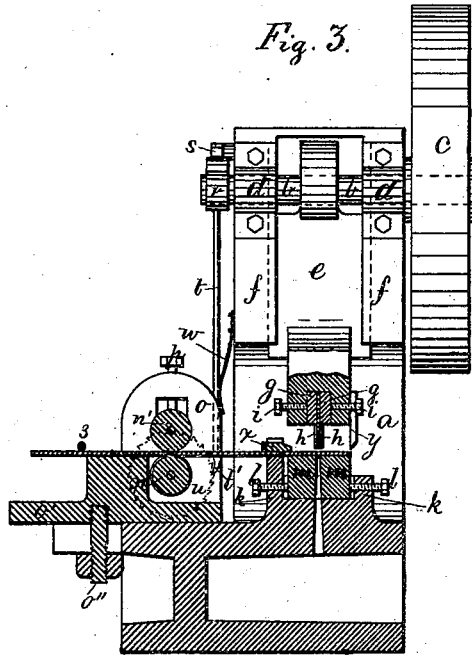

Witnesses:

Henry Chadbourne.
 H. Allen

Inventor.

Joseph M. Laughlin
 by
 Urban Andrew
 his atty.

J. M. LAUGHLIN.

MACHINE FOR MAKING HORSESHOE NAILS.

No. 189,108.

Patented April 3, 1877

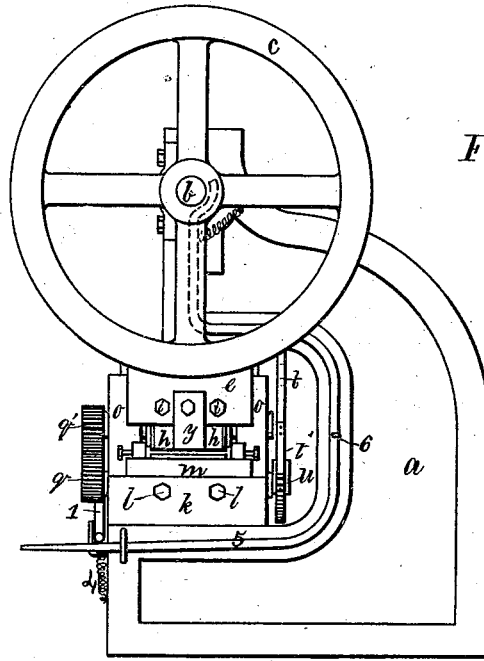

Fig. 6.

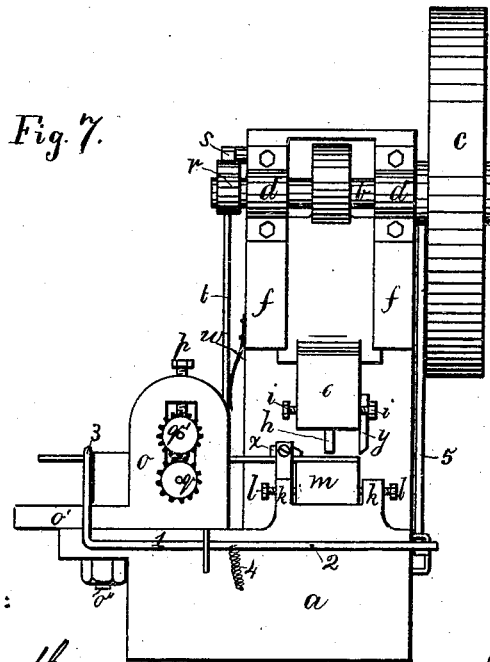

Fig. 7.

Witnesses:

Henry Chadborn.
 H. Allen

Inventor:

Joseph M. Laughlin
 by
 Albert Andrew
 his atty.

UNITED STATES PATENT OFFICE.

JOSEPH M. LAUGHLIN, OF BOSTON, MASSACHUSETTS.

IMPROVEMENT IN MACHINES FOR MAKING HORSESHOE-NAILS.

Specification forming part of Letters Patent No. **189,108**, dated April 3, 1877; application filed September 21, 1876.

To all whom it may concern:

Be it known that I, JOSEPH M. LAUGHLIN, of Boston, in the county of Suffolk and State of Massachusetts, have invented certain new and useful Improvements in Machines for Making Horseshoe-Nails; and I do hereby declare that the following is a full, clear, and exact description thereof, which will enable others skilled in the art to which it appertains to make and use the same, reference being had to the accompanying drawings, and to letters of reference marked thereon, which form a part of this specification.

My invention relates to improvements in machines for making horseshoe-nails; and consists of the combination, with a punching-machine, of a beveling-machine having an intermittent, but positive, motion imparted to it from the punching-machine, and suitable connecting mechanism between the two machines. The object in view is to bevel and run the nail-plate between the rollers, and to let the rollers and nail-plate held between remain at rest during the time the punch on the punching-machine performs its work in punching the nails from the plate. After the punch has performed its work, and has ascended above the plate, the rollers are automatically set in a rotary motion, and thus bevel and present a new portion of the plate to the action of the punching-machine. The width of the nail-plate may be such as to present one or more lengths of nails to be punched at one operation from the said plate, and the punching-machine may be provided with one or more punches, so as to punch one or more nails at each descent of the punching-machine, as may be desired.

In this manner I am able to produce a finished nail from a nail-plate with one single machine that shall embody in itself a beveling and feeding machine, as well as a punching-machine. The beveling-machine may be used independent of the punching-machine, and the nail-plate, after being beveled, may be fed in any suitable manner to the punching-machine, if so desired.

The nail-plate that is shaped between the aforesaid rollers is to be presented to the action of the punch of the exact shape, or nearly so, of the longitudinal section of a nail. The

nail-plate presented to the beveling-machine is in the form of long and narrow strips of homogeneous metal, the advantage of which is, that I am able to produce a better nail and to run the machine a longer time without stopping it.

The beveling-machine consists of a pair of rollers, one of which is provided with a number of projections arranged in single or double rows, by which a number of depressions or indentures are formed on the nail-plate, serving for the formation of the point or bevel of the nail when punched by the punching-machine.

On the accompanying drawings, Figure 1 represents a plan of my invention. Fig. 2 represents a sectional side elevation of the same. Fig. 3 represents a sectional front elevation. Fig. 4 represents the roller used for shaping the nail-plate; and Fig. 5 represents a cross-section on the line A B, shown in Fig. 4. Fig. 6 represents a side view. Fig. 7 represents a front elevation.

Similar letters refer to similar parts wherever they occur on the different parts of the drawings.

a represents the frame of an ordinary punching-machine, of which *b* is the driving-shaft, *c* is the driving or balance wheel, *d d* are the bearings, and *e* the block or head moved up and down in the guides *f f* by means of a crank or eccentric on the driving-shaft *b*, or in any other well-known manner. *g g* are the punch-holders in the lower part of the head *e*; and *h h* are the punches, secured in their proper positions by means of the screws *i i*, or equivalent device. *k k* represent the die-holders, provided with set-screws *l l*, or equivalent and well-known devices for adjusting and securing the die *m* in its proper position in relation to the punches *h h*. *n n'* represent the rollers, movable around their axis in bearings in the frames *o o*, and provided with regulating-screws *p p* and gears *q q'*, in the ordinary way. The roller *n* receives an intermittent rotary motion from the driving-shaft *b* on the punching-machine by means of the eccentric *r*, secured to the shaft *b*, acting upon a lever, *s*, the rear end of which is connected to a rod, *t*, having a pawl, *t'*, in its lower end, that operates a ratchet-wheel, *u*, on the shaft of the roller *n*. Springs *v w* are shown for the pur-

pose of raising the pawl *t'* as soon as the eccentric *r* ceases to act upon the lever *s*, and for the purpose of holding the said pawl *t'* in contact with the teeth of the ratchet-wheel *u*.

I wish, however, to state that the exact connecting mechanism from the punching-machine to the rollers, as shown in the drawings, for the purpose of producing an intermittent motion on the rollers from the rotary driving-shaft on the punching-machine, is not absolutely necessary to produce the effect desired, and I can, to equal advantage, substitute therefor other and well-known devices without departing from the spirit of my invention.

Figs. 4 and 5 show the roller *n*, provided with a number of projections, *n''' n''' n'''*, arranged in one or two rows, for the purpose of making indentures or recesses on the nail-plate during the revolution of the rollers. The point or bevel of the nail is formed by being punched where the recess on the plate is located. This kind of roller takes very little power to produce the desired indentures.

X represents a guide or rest for the nail-plate, for the purpose of preventing the latter from rising upward when the punch ascends after having punched the nail from the plate; *y* is the waste-cutter, secured to the head *e* of the punching-machine, for the purpose of automatically cutting up the waste stock that remains on the nail-plate after the nails are punched therefrom.

The frames *o o*, for the rolling-machine, are made in one piece with the sole-plate *o'*, that is adjustable by means of the set-screw *o''*, or equivalent device, toward and from the punch on the punching-machine, for the purpose of adjusting the proper position of the rolling-machine in relation to that of the punching-machine.

Having thus fully described the nature, construction, and operation of my invention, I wish to secure by Letters Patent, and claim—

1. The combination, with a punching-machine, of a beveling-machine, provided with beveling-rollers for forming indentations or depressions, substantially as described, and suitable connecting mechanism, by which a rotary, but intermittent, motion is imparted to the rollers *n n'* from the punching-machine, as and for the purpose set forth and described.

2. The combination, with a beveling-machine, of the roller provided with projections around its circumference, substantially as and for the purpose set forth and described.

In testimony that I claim the foregoing as my own invention I have affixed my signature in presence of two witnesses:

JOSEPH M. LAUGHLIN.

Witnesses:

ALBAN ANDRÉN,
HENRY CHADBURN.