

G. DOUGLASS.

DIES FOR FORMING SUCKER-ROD JOINTS.

No. 189,200.

Patented April 3, 1877.

Fig:1.

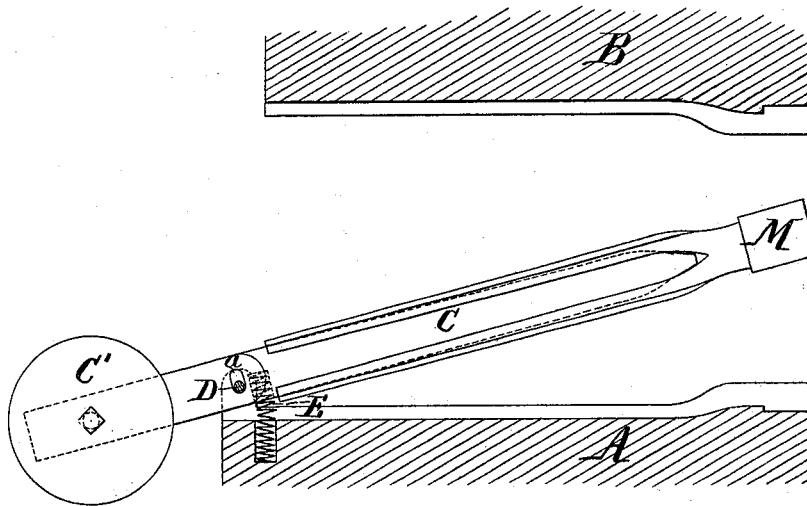

Fig:3.

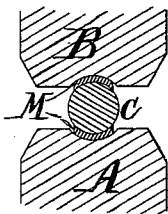
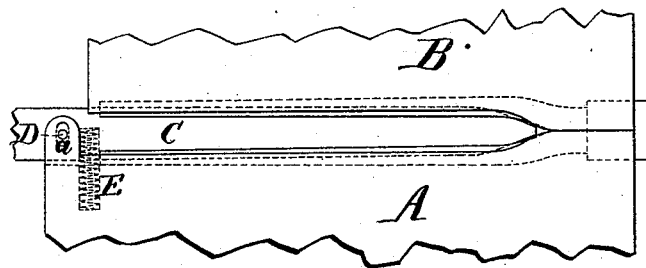

Fig:2.



Witnesses:

*A. Henry Gentner*  
*Chas. C. Stetson*

Inventor:

*George Douglass*  
*by his attorney*  
*Thomas D. Stetson*  
*New York*

# UNITED STATES PATENT OFFICE.

GEORGE DOUGLASS, OF BRIDGEPORT, CONNECTICUT.

## IMPROVEMENT IN DIES FOR FORMING SUCKER-ROD JOINTS.

Specification forming part of Letters Patent No. **189,200**, dated April 3, 1877; application filed February 5, 1877.

*To all whom it may concern:*

Be it known that I, GEORGE DOUGLASS, of Bridgeport, in the county of Fairfield and State of Connecticut, have invented certain new and useful Improvements in Dies for Forming Forked Articles; and I do hereby declare that the following is a full and exact description thereof.

I provide a pair of suitable dies for compressing and forming the exterior surfaces, and a tongue for entering and filling the space between the forks, and compressing and forming the interior surfaces. The tongue is held up in an approximately central position, to allow the application and removal of the forked articles, with capacity for yielding and assuming a correct position as the dies come together.

My experiments with the invention have been directed to the manufacture of what are known as "sucker-rod joints," used in the oil regions for connecting the wooden rods for operating in deep wells. They are some twenty inches long and two inches in diameter; but the invention may be applied to produce other articles larger or smaller.

The following is a description of what I consider the best means of carrying out the invention as applied to the manufacture of sucker-rod joints.

The accompanying drawings form a part of this specification.

Figure 1 is a central vertical section with the dies open, with a sucker-rod joint which has just been treated ready to be removed. Fig. 2 is a side elevation of the same with the dies together; and Fig. 3 is a cross-section, showing the last-named condition.

Similar letters of reference indicate like parts in all the figures.

A is a stationary or bed die, formed with lugs or vertical guides, having holes adapted to receive the transverse pin D, which supports the intermediate die or tongue C, and to steady the tongue laterally, and allow it to turn on the axis D as a center, and also to move bodily up and down to the extent allowed by the length of the slot *a* in the tongue C. B is a moving die, which may be attached to a powerful drop, or may be worked by a screw, or by hydraulic or other power, as conven-

ience or the character of the forked article to be manufactured may require.

The tongue C is formed with a counter-balance, C', and is also subject to the force of a spring, E, at the point designated.

When the die B is raised the tongue C rises and assumes an inclined position, its end or point standing at an elevation between the dies A B, out of contact with either. The joint-bolt D is then in the lower end of the slot *a*.

In this position the forked piece, which I will designate by the letter M, which has just been treated, may be easily removed by an end pull, and a new blank being brought from the fire and thrust upon the tongue C, it is in position to be treated by the next descent of the die B. The closing of the dies first brings the tongue C and its rider M into a horizontal position, and then depresses the whole, and induces a forcible contact between not only the interiors of the dies A and B and the exterior faces of the forked piece M, but also compels a corresponding forcible contact between the tongue C and the interior of the forked piece, so that the whole is properly swaged and straightened at a single blow.

The slot *a* must be made of sufficient height and the range of motion of the spring E must be made sufficient to allow a considerable vertical motion of the tongue C at that point.

Care should be taken in applying the hot piece M upon the tongue C to force it quite home, so that the end or point of the tongue shall extend quite up to the crotch of the fork.

My experiments indicate that what is sometimes designated the "crimping" of the forks, by which is meant the imparting of the proper curvature in cross-section, may be completely effected at a single operation. The forging should, of course, be drawn to an approximately proper thickness in all its parts before being treated in my dies.

Many variations may be made in the details without sacrificing the advantages of the invention. A very obvious change is to key or otherwise set the bolt D firmly in the tongue C, and to make the vertical slot to allow play in the lugs. I consider this in all requisites equivalent to the construction.

Some of the features of my invention may be used with success without the others. Thus, for example, the counter-balance C' may be dispensed with, and the force of the spring E sufficiently increased to properly hold up the tongue; but I prefer to use the whole together about as here shown, varying the forms of the tongue C and of the dies A B, as required by the forms and proportions of the articles to be treated. I believe it practicable to make a great variety of forked articles, from tuning-forks and jew's-harp frames up to the heaviest forgings required in railway suspension-bridges, and similar work.

The combination of the weight C' with the other parts tends to impart steadiness to the action, and allows a great degree of looseness in the joint D a, and of mounting the spring E nearer thereto than would be otherwise practicable.

I claim as my improvement in dies for swaging and straightening forked articles—

1. In combination with the intermediate die C and main dies A B, the yielding joint D a, adapted to provide for the bodily movement of the tongue C, and also for its turning or changing its inclination, as herein specified.

2. The spring E, in combination with the tongue C, bolt or axis D, slot a, and dies A B, as herein specified.

3. The counter-balance or partial counter-balance C' on the tongue C, in combination with the spring E, loose joint D a, and dies A B, as herein specified.

In testimony whereof I have hereunto set my hand this 31st day of January, 1877, in the presence of two subscribing witnesses.

GEORGE DOUGLASS.

Witnesses:

GEO. A. STAPLES,  
T. R. CRITTENDEN.