

A. F. JACKSON.
BOLT-HEADING MACHINE.

No. 189,226.

Patented April 3, 1877.

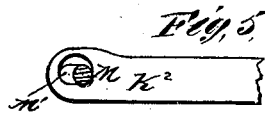
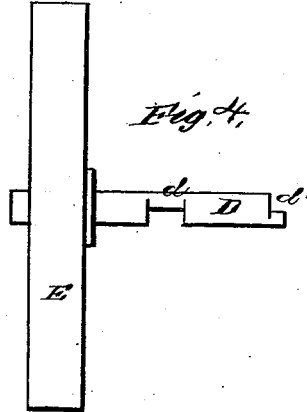
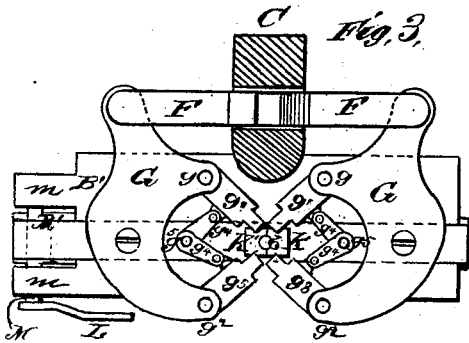
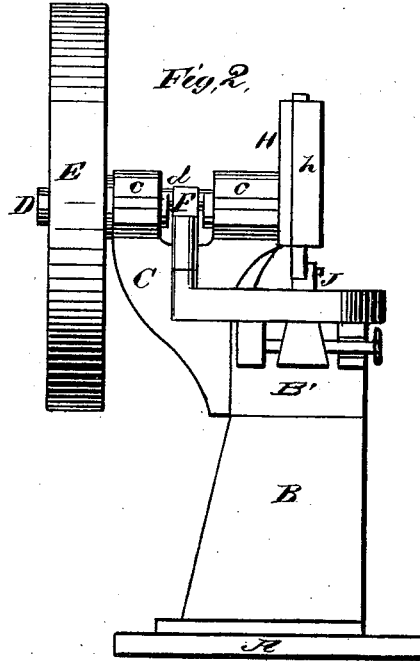
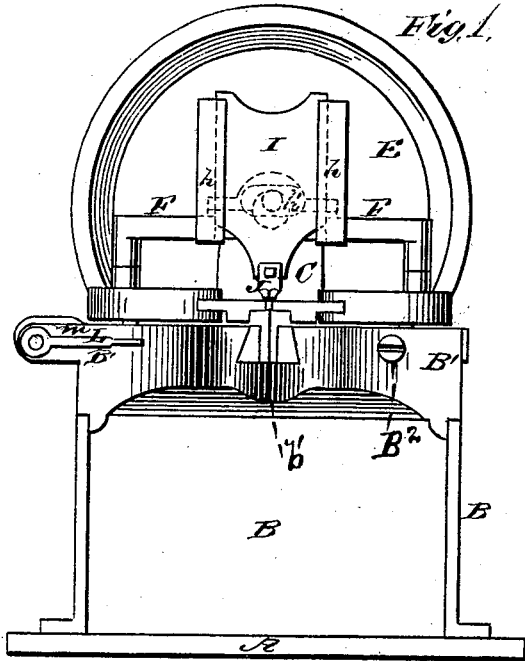

WITNESSES
A. H. Bates
George E. Upham

INVENTOR.
Aubrose F. Jackson
Gibbons & Smith
ATTORNEYS

UNITED STATES PATENT OFFICE.

AMBROSE F. JACKSON, OF MINNEAPOLIS, MINNESOTA.

IMPROVEMENT IN BOLT-HEADING MACHINES.

Specification forming part of Letters Patent No. 189,226, dated April 3, 1877; application filed December 16, 1876.

To all whom it may concern:

Be it known that I, AMBROSE F. JACKSON, of Minneapolis, in the county of Hennepin and State of Minnesota, have invented a new and valuable Improvement in Bolt-Heading Machines; and I do hereby declare that the following is a full, clear, and exact description of the construction and operation of the same, reference being had to the annexed drawings, making a part of this specification, and to the letters and figures of reference marked thereon.

Figure 1 of the drawings is a representation of a front elevation of my bolt-heading machine, and Fig. 2 is a side elevation of the same. Fig. 3 is a plan view thereof, part sectional, and Figs. 4 and 5 are detail views.

This invention relates to machines for heading bolts, and is an improvement on the machine described in Letters Patent granted to me, dated July 4, 1876, No. 179,563. The novelty consists in the novel construction and arrangement of the parts, as will be hereinafter more fully set forth.

In the annexed drawings, A designates the bed-piece of my apparatus, and B the pedestal or supporting-frame, which should be made sufficiently strong to endure the jarring of the dies and the upset or spreader, hereinafter described. On the rear of said pedestal or supporting-frame B is secured an upright bifurcated standard, C, which forms bearings *c c* for the driving-shaft D, operated by driving-wheel E. Said shaft, as shown in detail in Fig. 4, is recessed near its middle portion, so as to form an eccentric crank-wrist, *d*, which, when in operation, is located between the bearings *c c*. The said eccentric or crank-wrist *d* imparts a reciprocating motion to the yoke F, which may be arranged on the shaft D in any suitable manner. The lower extreme ends of said yoke are pivotally connected to the rear ends of two curved horizontal arms, G, which are pivoted, at or near their middle parts, to blocks set into the top piece of said pedestal or frame B, as hereinafter described. Each of said curved arms is provided, on its inner face and to the rear of its pivotal point, with a projecting bracket or attaching-block, *g*, to which is pivotally secured a die, *g*¹; and it is also provided at its outer end with a similar

inwardly extending bracket or attaching-block, *g*², to which is pivoted a die, *g*³. Said dies are connected, by means of links *g*⁴ *g*⁴, to pins *g*⁵ *g*⁵, which are fixed relatively to said dies. This attachment retains said dies in such position as to form two contiguous sides of a bolt-head; but as said links are pivoted at both ends, the said dies are free to be alternately advanced and retracted without departing from a right-line motion.

To the front of bifurcated standard C, overhanging the central part of the top piece B¹ of main supporting-frame or pedestal B, I attach a vertical guide-plate, H, one face of which is provided with side-guiding flanges *h h*, and the other face of which is cut away at *h'*, as indicated in dotted lines in Fig. 1, to allow the passage and play of an eccentric stud or wrist-pin, *d'*, on the end of shaft D. Said eccentric stud or wrist-pin *d'* sets into a recess in the rear of a slide, I, which is operated thereby so as to reciprocate vertically in guide-plate H, between flanges *h h*. Said slide carries on its lower end a pointed spreader or upset, J, which operates at each descent to spread the top of the bolt-blank, so as to form a head. The sides of the head are then shaped by the dies already described. The forward die *g*³ of one arm, G, operates simultaneously with the rear die *g*¹ of the other arm, and as these dies recede the others advance and operate.

Top piece B¹ of pedestal B is constructed with a recess, *b'*, extending inwardly from the middle of its front, to allow the bolt-blank to be inserted in a vertical position under the spreader J and between the four dies already described. Said top piece is also recessed to receive the blocks of the clamping-jaws K K¹, which operate as a vise to hold the said bolt-blank while it is being headed, as described. Jaw K is adjustable, and held in position during the operation of the machine, by means of a set-screw, B², or its equivalent, but jaw K¹ is reciprocated lengthwise by the following devices: L, Fig. 3, designates a crank-arm, which operates a shaft, M, journaled in lugs *m m* attached to one side of top piece B¹. Said shaft is provided with an eccentric, M', and passes through a perforation in the end K² (as shown in Fig. 5) of the jaw K¹. By turning said crank outwardly the said jaw is caused to re-

cede from jaw K. By turning it inwardly the opposite motion is produced. As one of the operating-arms G, together with its dies and links, is pivotally attached to the top of said sliding block, said jaw, in its movement, carries with it the arm and dies attached thereto. It is evident that by adjusting jaw K the machine may be adapted to blanks of different sizes.

The motion of all the parts of my device is positive, and the reciprocatory movements of the vertical upset or spreader and the horizontal dies are all produced by the same wheel and shaft.

What I claim as new, and desire to secure by Letters Patent, is—

1. The combination, with the shaft D, of the yoke F F, the lower ends of which are pivoted to two horizontal arms, G, carrying the bolt-heading dies, substantially as and for the purpose set forth.

2. The combination of shaft D, having crank *d*, with angular yoke F F and horizontal die-carrying arms G G, substantially as set forth.

3. In a bolt-heading machine, a shaft, provided with two eccentrics, arranged so as to operate both the vertical spreader and the horizontal dies by direct and positive motion, substantially as set forth.

4. Arm G, in combination with sliding jaw K¹ K², dies *g*¹ *g*², links *g*³ *g*⁴, and pin *g*⁵, substantially as set forth.

5. The combination of jaws G G, having the rear dies *g*¹ and the forward dies *g*², with links *g*³ *g*⁴ and pins *g*⁵, substantially as set forth.

In testimony that I claim the above I have hereunto subscribed my name in the presence of two witnesses.

AMBROSE F. JACKSON.

Witnesses:

ROBERT S. BRYANT,
L. M. STEWART.