

R. REINHARD.

DEVICE FOR THROWING BELTS ON PULLEYS.

No. 189,263.

Patented April 3, 1877.

Fig. 1.

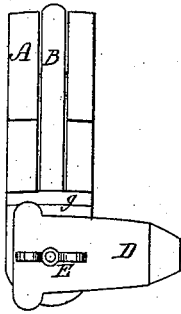

Fig. 2.

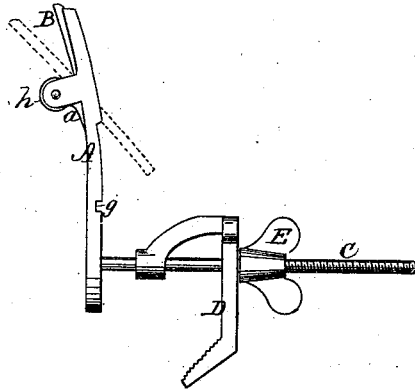

Fig. 3.

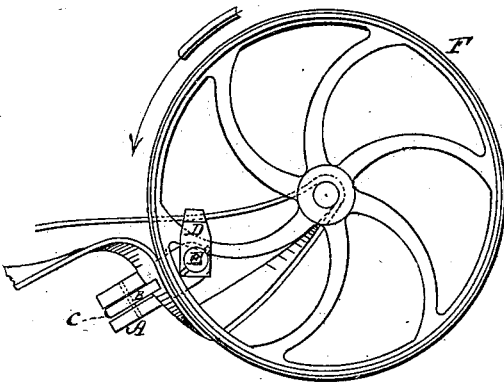
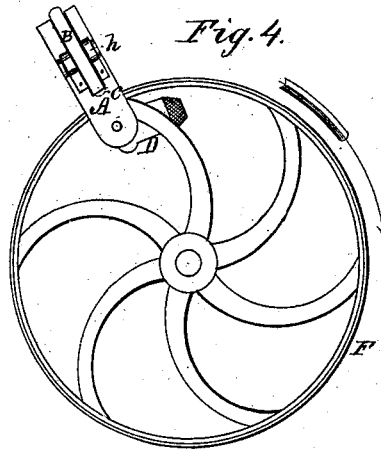

Fig. 4.



WITNESSES:

John Kemou
A. W. Hart.

INVENTOR:

Robt. Reinhard

BY

Reinhard & Co.

ATTORNEYS.

UNITED STATES PATENT OFFICE.

ROBERT REINHARD, OF LANGENDREER, PRUSSIA, ASSIGNOR TO WILLIAM
H. REINHARD, OF HUNTINGTON, INDIANA.

IMPROVEMENT IN DEVICES FOR THROWING BELTS ON PULLEYS.

Specification forming part of Letters Patent No. **189,263**, dated April 3, 1877; application filed
January 4, 1877.

To all whom it may concern :

Be it known that I, ROBERT REINHARD, of Langendreer, in the county of Bochum, Prussia, have invented a new and Improved Device for Throwing Belts on Pulleys; and I do hereby declare that the following is a full, clear, and exact description of the same.

The object of my invention is to provide a simple, cheap, and efficient device for applying broad or tightly-stretched bands or belts to pulleys, and thereby avoid the difficulty and danger incident to such operation when effected by hand, in the usual way.

The accompanying drawing, forming part of this specification, shows the construction of said device, and also the manner of applying it in practice.

Figure 1 is a plan view of the device. Fig. 2 is a side view. Figs. 3 and 4 show the manner of applying the device in practice.

The device consists of a slotted plate, A, having a spring-clamp, B, for holding the edge of the belt, a screw-threaded rod, C, which is rigidly attached to said plate, and also placed at right angles to it, and a bent or curved arm, D, adapted to slide on the screw-rod C, and to be held in any adjustment by means of a winged nut, E.

The clamping-bar B is arranged to work in a lengthwise slot of plate A, pivoted thereto at its middle, and provided with springs *a*, coiled around its trunnions or journals, for the purpose of causing the bar to press tightly against the edge of the belt, when inserted between it and the plate A, as shown in Fig. 3, and thus hold the belt securely. The device is secured to a pulley, F, by placing the plate A with its inner side against the edge of the latter, and the bent arm D against the contiguous spoke, as shown in Figs. 3 and 4, the plate being, in such case, radial to the axis of the pulley. The nut E is then screwed up tightly

against the arm D, thus causing the plate to press against the edge of the pulley-rim to the same degree the arm presses against the spoke in the opposite direction.

The edge of the pulley is received into a transverse groove, *g*, in the plate, and the latter is thereby prevented from being thrown out of its radial position by the strain of the belt when clamped thereto. This last result is effected by turning the bar on its journal to raise its lower end out of the slot, and placing the belt beneath said lower end of the bar. The action of the coiled springs *h* then causes the bar to clamp the belt and hold it securely till the rotation of the pulley carries the device around, and thus throws on the belt, the latter being simultaneously freed from the clamp by its own tension.

The belt is thus applied without the difficulty, delay, and personal danger attending the operation when effected in the usual way.

The device can remain attached to the pulley after the belt has been thrown on, until such time as convenience may allow its removal.

What I claim is—

The device hereinbefore described, consisting of a plate, A, having a groove, *c*, and a spring clamping-bar, B, a screw-rod rigidly attached to part A, at right angles, an arm, D, adapted to slide on the rod, and a nut for securing it in any adjustment, substantially as shown and described, to operate as specified.

The above specification of my invention signed by me this 28th day of November, A. D. 1876.

ROBERT REINHARD.

Witnesses:

HEINRICH SCHLÜTER,
THEODOR BÖRSING.