

G. SMITH.  
MULTIPLE TELEGRAPH.

No. 189,276.

Patented April 3, 1877.

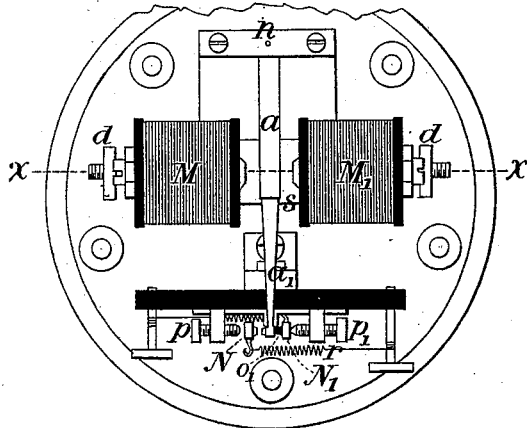

Fig. 1.

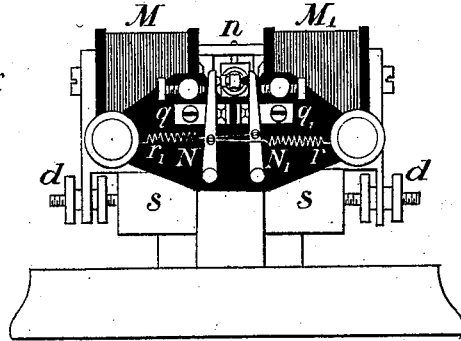

Fig. 2.

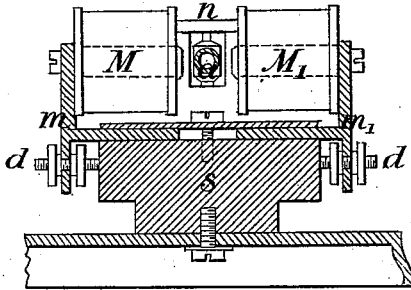

Fig. 3.

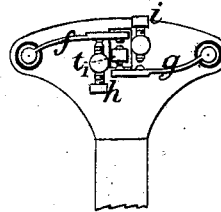

Fig. 4.

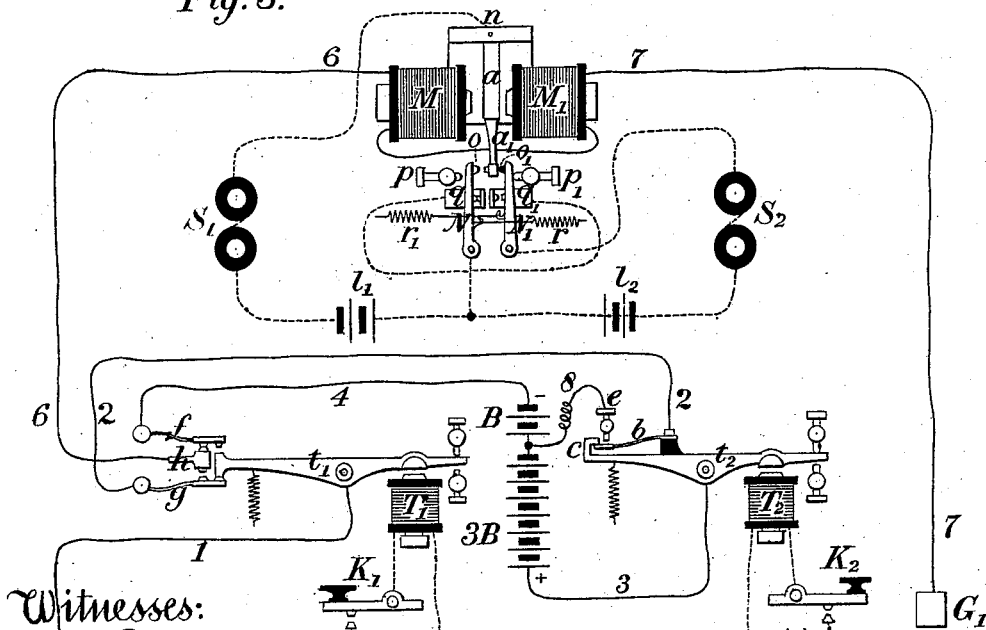

Fig. 5.

Witnesses:  
Frank L. Pope,  
George A. Hamilton.

Inventor,  
Gerritt Smith

G. SMITH.  
MULTIPLE TELEGRAPH.

No. 189,276.

Patented April 3, 1877.

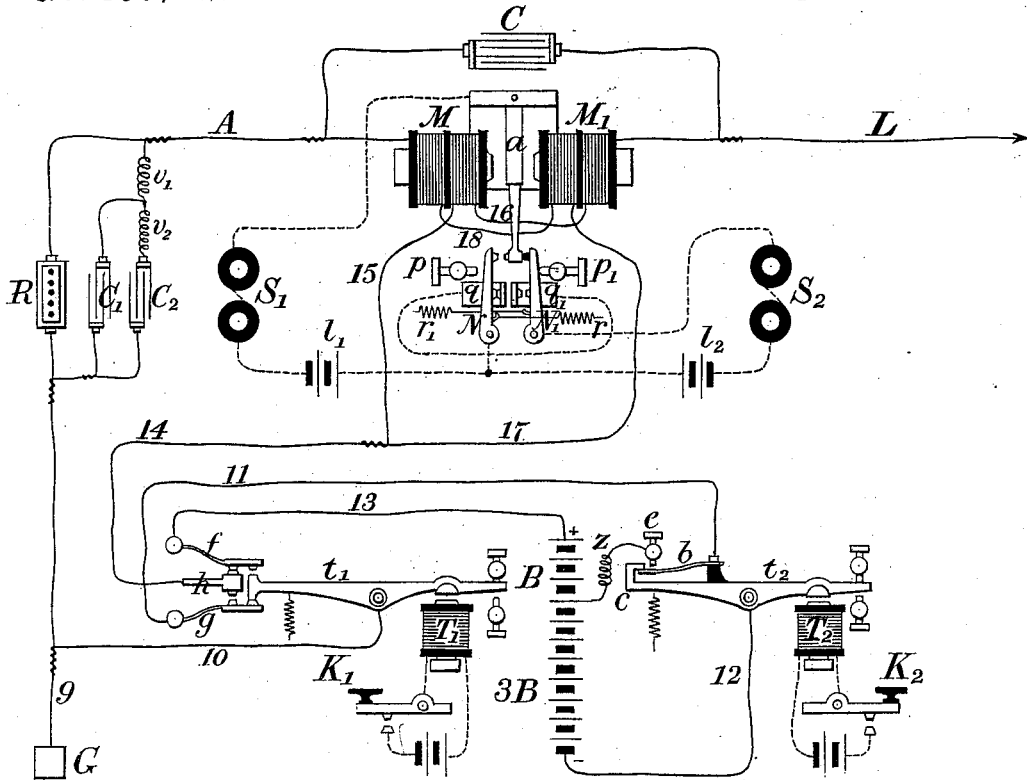

Fig. 6.

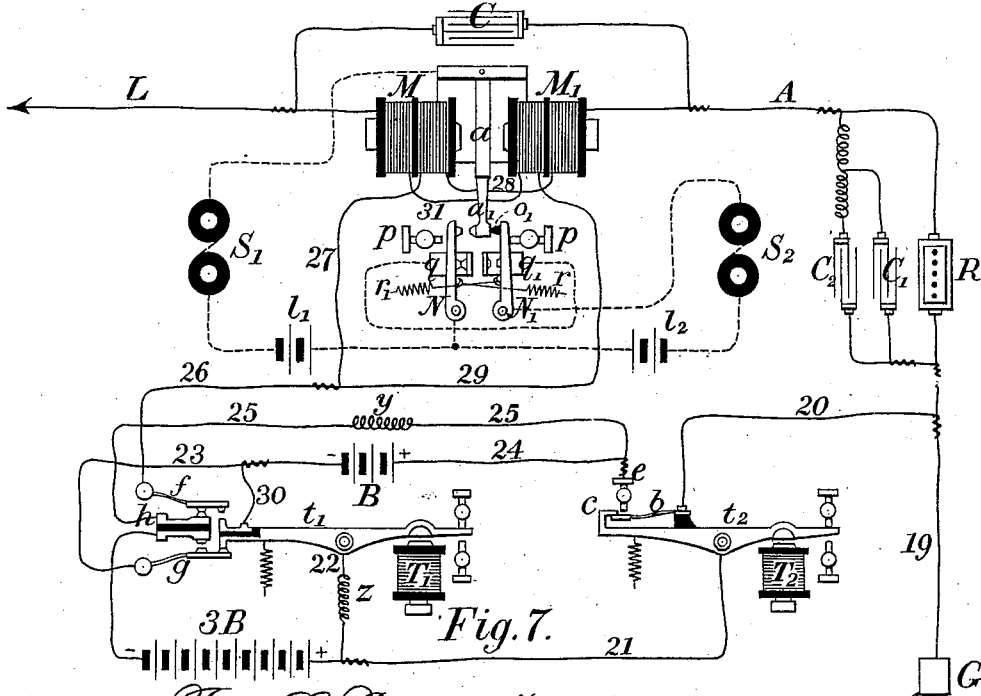

Fig. 7.

Witnesses: Frank L. Pope,  
George A. Hamilton.

Inventor, Gerritt Smith

G. SMITH.  
MULTIPLE TELEGRAPH.

No. 189,276.

Patented April 3, 1877.

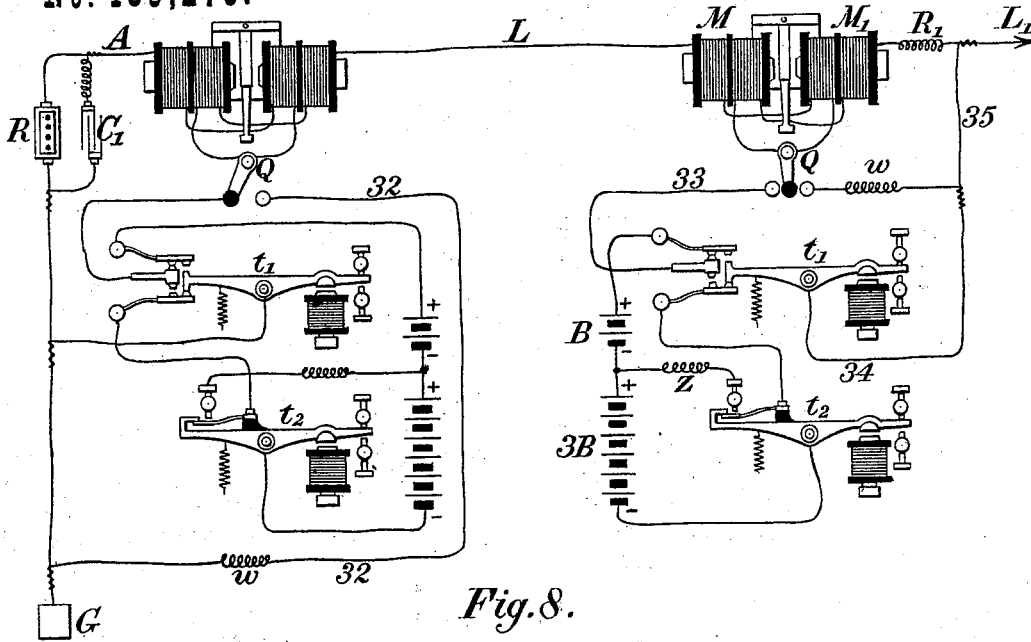

Fig. 8.

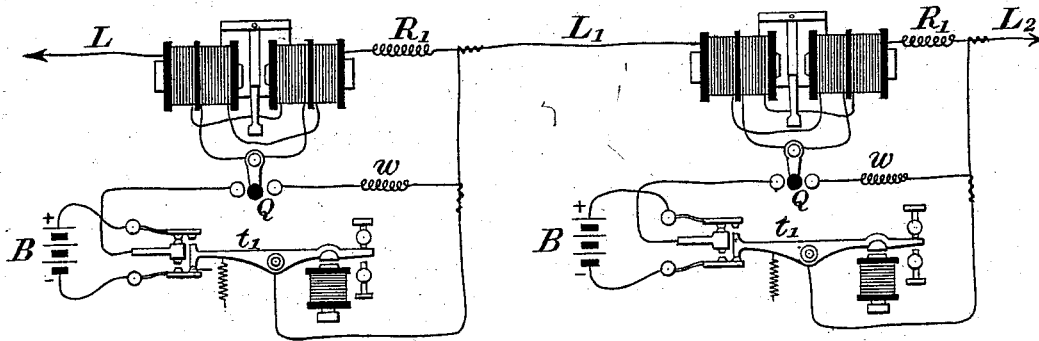

Fig. 9.

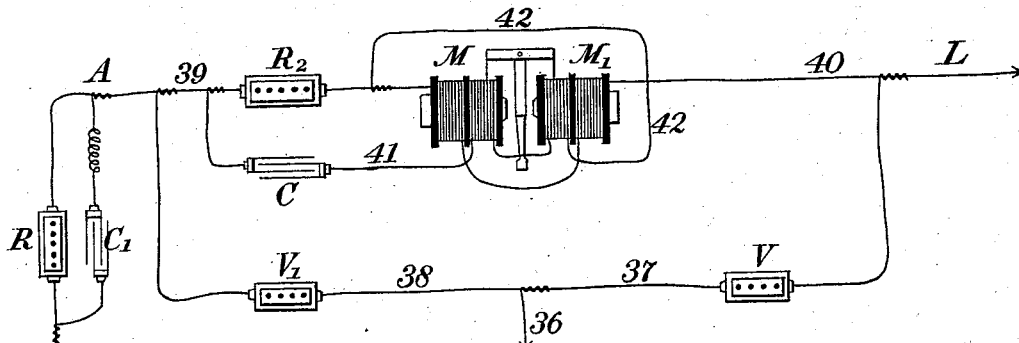

Fig. 10.

Witnesses:

Frank L. Pope  
George A. Hamilton

Inventor,

Gerritt Smith.

# UNITED STATES PATENT OFFICE.

GERRITT SMITH, OF ASTORIA, NEW YORK, ASSIGNOR OF ONE-HALF HIS  
RIGHT TO GEORGE B. PRESCOTT, OF NEW YORK, N. Y.

## IMPROVEMENT IN MULTIPLE TELEGRAPHS.

Specification forming part of Letters Patent No. **189,276**, dated April 3, 1877; application filed  
February 10, 1877.

*To all whom it may concern:*

Be it known that I, GERRITT SMITH, of Astoria, in the county of Queens and State of New York, have invented certain new and useful Improvements in Multiple Telegraphs, which improvements are fully set forth in the following specification, reference being had to the accompanying drawing.

The object of my invention is to provide an improved means whereby two distinct communications may be simultaneously transmitted over one telegraphic conductor in the same direction, and which may also be combined with any suitable one of the several known methods of simultaneous double transmission in opposite directions, so that by means of such combination four distinct communications, two in each direction, may be made to pass simultaneously over a single conductor without interfering with each other.

In all methods of transmission of this character hitherto known it has been necessary to make use of a double-acting receiving-instrument or relay at the receiving-station composed of a single electro-magnet, having two or more armatures, or else of two or more independent receiving-instruments.

The practical objection to the first-mentioned arrangement is that the effective attraction of the electro-magnet for any one of two or more armatures is materially lessened whenever one of the others is already in contact, or nearly in contact, with its poles. Thus the movements of the separate armatures necessarily interfere with each other, which interference tends to confuse the signals. The second arrangement is now in very general use, and, though free from the hereinbefore-mentioned objections, is liable to certain other defects arising from the use of two independent receiving-instruments, the principal of which are as follows: When the apparatus is arranged for the simultaneous transmission of two communications in each direction it is very difficult to adjust the equating-resistances and condenser-capacities, so that neither of the two receiving-instruments are affected by the variations in the strength or polarity of the outgoing currents, as the changes necessary to effect the proper

adjustment or balance of one receiving-instrument frequently destroy the balance of the other, and much care and skill are required to accomplish the desired result. Again, when two receiving-instruments are used, one must be made so sensitive that it will respond readily to weak currents. The other must be very much less sensitive, responding only to currents of considerable power. The strength of current required to actuate the latter instrument is so great that it sometimes affects injuriously the working of the more delicate one.

My present invention is intended to overcome the above-mentioned difficulties; and it consists, principally, in an improved double-acting receiving-instrument or relay, which is placed at the receiving-station, and is composed of an electro-magnet which acts upon a single armature. The said armature is capable of being placed, by the action of the electro-magnet, in four different positions, corresponding to the four possible positions of the two keys at the sending-station. By means of suitably-arranged contact-levers two independent local circuits are brought into action by the same armature in its different positions, which circuits, in turn, actuate two independent sounding or recording instruments. My invention further consists in an improved combination or arrangement of the keys or transmitters, with reference to the batteries at the transmitting-station, and also in certain improvements in the construction of the pole-changing transmitter.

Figure 1 is a plan view of an improved receiving-instrument or relay which forms an important part of my invention. Fig. 2 is a front elevation, and Fig. 3 a transverse vertical section, of the same, taken in the plane of the dotted line *xx* in Fig. 1. Fig. 4 is a front elevation of the double-current or pole-changing transmitter. Fig. 5 is a skeleton diagram, showing the connections and mode of operation of my improved apparatus when arranged to transmit two messages simultaneously in the same direction, from one terminal station to another. Fig. 6 shows the apparatus as arranged upon the differential plan at one terminal station, for the purpose of simultane-

ously transmitting two communications to the distant station, and receiving two others from that station. Fig. 7 is a modification of the arrangement shown in Fig. 6. Figs. 8 and 9 show different methods of arranging the apparatus at way-stations, and Fig. 10 shows the apparatus at a terminal station arranged upon the bridge plan.

In order that two communications may be simultaneously transmitted in the same direction over the same conductor, it is necessary to make use of two independent transmitting instruments or devices at the sending-station, and also of two independent sounding or recording instruments at the receiving-station.

For the purposes of this description it will be assumed that the method of telegraphic transmission known as the "Morse system" is used, although any other electro-magnetic system of telegraphy may be substituted therefor.

I will first describe the construction and mode of operation of my improved receiving-instrument or relay, and afterward proceed to explain the manner in which it may be combined with other well-known apparatus in order to effect the simultaneous transmission and reception of two communications in the same or in opposite directions, or both, upon one conductor.

In Figs. 1 and 3,  $ns$  is an angular bent permanent magnet, preferably of hardened steel, magnetized to saturation, the south pole  $s$  of which is made broad enough transversely to form a bed, the grooved upper surface of which supports two soft-iron carriages,  $mm$ . (See Fig. 3.) To a lug projecting upward from each of these carriages is screwed the soft-iron core of an electro-magnetic coil or helix, as seen at  $M$  and  $M_1$ .

The respective poles of the two cores are arranged so as to face each other upon opposite sides of a soft-iron or steel armature,  $a$ , which is pivoted at  $n$  within a slot formed in the north end of the permanent magnet  $ns$ . The poles projecting from the helices  $M$  and  $M_1$  may be adjusted at any required distance from the armature  $a$  by moving the carriages  $mm$  horizontally in either direction, as required, and securing them in the desired position by the check-nuts  $dd$ . The coils  $M$  and  $M_1$  are included in the same electric circuit. When no current is passing the armature  $a$  receives north magnetic polarity from the upper end of the permanent magnet  $ns$ , while the cores on each side of it in like manner both receive south polarity from the lower end thereof. It will therefore be attracted indifferently by either pole with a strength depending upon its distance therefrom. The effect of a positive current traversing the helices  $M$  and  $M_1$  will be to strengthen the south magnetism in the core of helix  $M$ , and weaken or neutralize that in  $M_1$ , thus causing the armature  $a$  to be attracted toward the former with a force proportional to the strength of the current trav-

ersing the helices. The effect of a negative current will, of course, be precisely the reverse of the foregoing, and the armature will be attracted toward the coil  $M_1$ .

I here remark that, although the combination of permanent and electro magnets which I have thus far described, and which I prefer to employ, is similar to that contained in the well-known Siemens relay, yet, owing to the peculiar arrangement of the electro-magnetic helices and their cores with reference to the armature, the heavy movable pole-pieces of Siemens' arrangement are dispensed with, whereby the cores themselves are rendered capable of being charged and discharged with increased rapidity whenever the polarity of the current is reversed. In any case the Siemens relay might be used in place of the modification thereof which I have described without departing from the principle of my invention.

The armature  $a$  controls the local circuits, which operate the sounding or recording instruments by means of two contact-levers,  $N$  and  $N_1$ , Figs. 2 and 5. These contact-levers turn freely upon suitable fulcrums at their lower ends, while their free upper ends, when at rest, are held against the adjustable contact-points  $q$  and  $q_1$  by the tension of the adjustable springs  $r$  and  $r_1$ .  $o$  is a contact-point upon the upper extremity of the contact-lever  $N$ , and  $o_1$  is an insulated stop occupying a corresponding position upon the lever  $N_1$ . The contacts  $q$  and  $q_1$  are so adjusted as to allow the arm  $a_1$ , which is rigidly attached to the armature  $a$ , to play between the stops  $o$  and  $o_1$  upon the contact-levers, which limit its motion in each direction except at such times as the armature  $a$  moves with sufficient power to overcome the retractile force of the springs  $r$  and  $r_1$ , in which case the lever  $N$  or  $N_1$  is pressed away from the contact  $q$  or  $q_1$  until it strikes against the adjustable stop  $p$  or  $p_1$ .

To the above-described receiving-instrument two independent sounding or recording instruments,  $S_1$  and  $S_2$  are connected in the manner shown in Fig. 5.

Each of the two local batteries  $l_1$  and  $l_2$  has one of its poles connected to the contact-lever  $N$ . The remaining pole of  $l_1$  is connected through the sounder  $S_1$  to the armature  $a$ , and the remaining pole of  $l_2$  through the sounder  $S_2$  to the other contact-lever  $N_1$ . A connection is also made between the stops  $q$  and  $q_1$ , as shown by the broken line.

The transmitting devices are, preferably, operated by connecting them either mechanically or electrically with the levers of common Morse keys in a manner well understood.

The operation of the two independent transmitters or keys at the sending-station gives rise to four different electrical conditions of the line according to their respective positions with reference to each other, as follows: First, first and second keys both open; second, first key closed and second key open; third, second key closed and first key open; fourth,

first and second keys both closed. The manner in which the four different electrical conditions of the line are produced by the operation of two transmitters will now be explained.

In Fig. 5,  $t_1$  is a lever capable of a slight vertical movement upon its axis in one direction by the attraction of the electro-magnet  $T^1$ , and in the other by the retractile force of a spring. This lever, with its appendages, constitutes what may be termed for convenience the double-point transmitter, and is preferably operated by means of a key,  $K_1$ , and a local battery, in a manner well understood.

The function of the double-point transmitter is to reverse the normal polarity of the main battery in respect to the line and ground wires whenever the key  $K_1$  is depressed, and this is effected by means of contact-springs  $f$  and  $g$ , Figs. 4 and 5, which tend to press against the adjustable stops  $h$  and  $i$  and make contact therewith, except when prevented from so doing by the action of the lever  $t_1$ . In its normal position, with the key  $K_1$  open, the end of the lever  $t_1$ , which acts upon the springs, is depressed, as shown in the figures. Thus the spring  $g$  is separated from the stop  $i$ , although it remains in contact with the lever  $t_1$ . The spring  $f$ , on the contrary, rests against the stop  $h$ , and is separated from the lever  $t_1$ . When the key  $K_1$  is closed, the position is precisely the reverse of this. The stops  $h$  and  $i$  should, preferably, be so adjusted that when the lever  $t_1$  moves up and down it will make contact with one spring before breaking contact with the other. As the two poles of the main battery are connected to the respective springs  $f$  and  $g$ , the line-wire to the stops  $h$   $i$ , and the earth to the lever  $t_1$ , it is obvious that at each movement of the lever the polarity of the current upon the line will be reversed. In the arrangement which I have adopted the contact-springs are not mounted upon the lever  $t_1$ , as heretofore, but upon an independent stationary support. This mode of construction simplifies the apparatus, and renders it much more convenient to adjust it properly by means of the contact-screws  $h$   $i$ . (See Fig. 5.)

The single-current transmitter  $t_2$  is operated by an electro-magnet,  $T_2$ , local battery, and key  $K_2$ , and serves to determine the strength of current going to line, without reference to its polarity. It is of well-known construction, and requires no detailed explanation.

I will next proceed to describe the effect produced upon the electrical condition of the line by the several positions of the keys at the transmitting-station.

I here remark that in the arrangement about to be described two main batteries,  $B$  and  $3B$ , are made use of, the latter being, say, three times the strength of the former.

1. When the first and second keys are both open: This is the position of the apparatus represented in Fig. 5.

Disregarding for the present the receiving-

instruments and their connection with the line, the circuit may be traced as follows: From the earth-plate  $G$ , through wire 1, transmitter-lever  $t_1$ , spring  $g$ , wire 2, spring  $b$ , contact-point  $e$ , transmitter-lever  $t_2$ , wire 3, main batteries  $3B$  and  $B$ , wire 4, spring  $f$ , contact-point  $h$ , thence over the line-wire 6 to the helices  $M$   $M$  of the receiving-instrument at the distant station, and thence by the wire 7 to the earth at  $G_1$ . In this position of the keys both main batteries are in circuit, sending to line a negative or  $-$  current of  $-3B-B=-4B$ .

2. When the first key is closed and the second key open: The route in this case is from the earth at  $G$ , by wire 1, lever  $t_1$ , spring  $f$ , wire 4, main batteries  $B$  and  $3B$ , wire 3, lever  $t_2$ , contact-point  $e$ , spring  $b$ , wire 2, spring  $g$ , contact-point  $h$ , and thence by the line 6 to the distant station, as before. In this position both main batteries are also in circuit, sending to line a positive or  $+$  current of  $3B+B=4B$ .

3. When the second key is closed and the first key open: The route in this case is from the earth at  $G$  by wire 1, lever  $t_1$ , spring  $g$ , wire 2, spring  $b$ , contact-point  $e$ , wire 3, main battery  $B$ , wire 4, spring  $f$ , contact-point  $h$ , and wire 6, thence over the line to the distant station. In this position the smaller of the two main batteries only is in circuit, sending to line a negative or  $-$  current of a strength of  $-B$ .

4. When both the first and second keys are closed: The route in this case is from the earth at  $G$ , through wire 1, lever  $t_1$ , spring  $f$ , wire 4, main battery  $B$ , wire 3, contact-point  $e$ , spring  $b$ , wire 2, spring  $g$ , contact-point  $h$ , and thence over the line 6.

In this position the smaller battery only is in circuit, sending to line a positive or  $+$  current of a strength of  $B$ .

The apparatus at the receiving-station consists of the double-acting receiving-instrument hereinbefore described, (shown in diagram in Fig. 5,) to which are connected two independent sounding or recording instruments,  $S_1$  and  $S_2$ .

It is obviously essential that one sounder (for example,  $S_1$ ) should respond solely to the movements of the key  $K_1$ , and the other sounder,  $S_2$ , in like manner, to the movements of the key  $K_2$ , while both should respond when both keys are depressed. The manner in which this result is accomplished will be understood by reference to the following explanation of the effect of each of the hereinbefore-mentioned electrical conditions of the line, and to Fig. 5 of the drawings.

1. Negative current from both batteries, ( $-4B$ ): The local circuit of sounder  $S_1$  is open between the point  $O$  and the armature  $a$ , and that of  $S_2$  between the lever  $N_1$  and the stop  $q_1$ , because the action of the current upon the polarized armature  $a$  tending to attract it toward  $M_1$  is strong enough to overcome the ten-

sion of the spring  $r_1$ , and force the lever  $N_1$  against the stop  $p_1$ .

2. Positive current from both batteries, (+4B:) The local circuit of sounder  $S_1$  is closed at the point of contact between arm  $a_1$  and contact-lever  $N$ , but that of sounder  $S_2$  is broken between the contact-lever  $N$  and the stop  $q$ , because the strength of the current upon the line is so great as to overcome the tension of the spring  $r$ , and force the lever  $N$  against the stop  $p$ .

3. Negative current from battery B only, (-B:) The local circuit of the sounder  $S_1$  is broken between the arm  $a_1$  and the contact  $O$  on the lever  $N$ , but that of sounder  $S_2$  remains closed, because the power of the current upon the line, though sufficient to move the arm  $a_1$  away from the stop  $o$ , is not able to overcome the spring  $r_1$  and separate the lever  $N_1$  from the stop  $q_1$ .

4. Positive current from battery B only, (+B:) The local circuits of both sounders  $S_1$  and  $S_2$  remain closed, because the strength of the positive current is sufficient to bring the arm  $a_1$  into contact with the stop  $o$  upon the contact-lever  $N$ , but is not enough to overcome the tension of the spring  $r$ , and thus separate the lever  $N$  from the stop  $q$ .

Thus it will be understood that the armature  $a$  is caused to assume four different positions, corresponding to the four different conditions of the line. When the armature is in either of its extreme positions, the local circuit of the sounder  $S_2$  is broken. When the armature passes directly over from one extreme position to the other, it, of course, closes the local circuit for an instant as it passes the middle point, but not long enough to produce any effect whatever upon the sounder  $S_2$ , which remains inactive.

In order to adapt the hereinbefore-described apparatus to the simultaneous transmission of four communications upon the same wire, two in each direction, it is only necessary to combine it with some suitable known method of simultaneous transmission in opposite directions. I prefer to employ for this purpose the method set forth in Letters Patent of the United States No. 136,874, which were granted to Joseph B. Stearns on the 18th of March, 1873. The combined apparatus is shown in Fig. 6, in which the helices  $M M_1$  of the receiving-instrument are each composed of two divisions having an equal number of convolutions, and so arranged as to exert equal and opposite magnetic effects upon the cores. The outgoing current through the wire 14 divides into two equal portions, one going to the main line  $L$  and the other to the artificial line  $A$ , in which is inserted a rheostat,  $R$ , corresponding in resistance to the main line. The main-line current passes from the transmitting apparatus through the wires 14 and 15, right-hand division of helix  $M$ , wire 16, right-hand division of helix  $M_1$ , and thence to the line  $L$ , while the current of the artificial line goes from the wire 14, by wire 17, to the left-hand division

of helix  $M_1$ , wire 18, and left-hand division of helix  $M$  to  $A$ , and thence through rheostat  $R$  to the earth at  $G$ . I also make use of condensers  $C_1$  and  $C_2$ , which are connected to the artificial line  $A$ , in the manner shown in the figure, for the purpose of compensating the static discharge of the line, in the manner fully set forth in Letters Patent of the United States No. 126,847, granted to Joseph P. Stearns on the 14th day of May, 1872, to which reference is had. In order to equalize the time of the discharge from the condensers, and render it of the same duration of that from the line, I prefer to arrange them in such a manner that the discharge is made to pass through adjustable rheostats  $v_1 v_2$ . An independent condenser,  $C$ , is arranged with one set of its plates in connection with the main line  $L$  and the other set with the artificial lines  $A$ . No effect is produced by this condenser upon the outgoing current, as the potential of the latter is substantially the same on each side. The incoming current from the distant station, meeting with the resistance of the helices  $M M_1$ , flows into and charges the condenser, which remains charged until a reversal of the current takes place upon the line, when it instantly discharges itself, and sends a momentary pulsation through the electro-magnets  $M$  and  $M_1$ , by the way of wires 15, 16, 17, and 18. This tends to hasten the action of the receiving-magnet upon its armature at each reversal, and thus improves the signals upon long lines. The effective action of this condenser may be much increased, if desired, by augmenting the resistance of the helices  $M M_1$ , or by inserting additional resistances between these and the junction of the wires leading to the condenser on each side.

Fig. 7 shows the application of my improved receiving apparatus to the method of transmission described in my former United States Letters Patent No. 187,588, dated December 19, 1876, to which reference is had, and in which the four positions of the keys  $K_1$  and  $K_2$  produce the following electrical conditions of the line: First key and second key both open, (+B;) first key closed and second key open, (-3B;) second key closed and first key open, (O;) first key and second key both closed; (-B.)

The arrangement of the receiving-instrument, local circuits, and sounders in this case is precisely the same as that shown in Fig. 5, except that care must be taken to adjust the coil  $M_1$  a little nearer the armature  $a$  than in the other case, so as to give it a bias toward that side. The same effect may be produced by attaching a slight spring to the arm  $a_1$ , which will be sufficient to hold it against the insulated stop  $o_1$  when no current is passing.

Fig. 8 shows a terminal station arranged in precisely the same manner as that already described and shown in Fig. 6, and also an intermediate station. A switch,  $Q$ , is provided at each station, by turning which to the right the main batteries are removed from

the main-line circuit, and a rheostat,  $w$ , having a resistance equal to the combined internal resistance of both batteries, inserted in their stead, which enables each station to adjust or balance its apparatus without interference from the batteries of any other station. By means of the arrangement shown in Fig. 8 either terminal station may send two simultaneous communications to the way-station or to the other terminal station, or to both; or it may send two and receive two simultaneous communications while corresponding with either the way or the other terminal station, but not both at the same time.

Fig. 9 shows an arrangement well adapted to the transmission of press-reports, or other matter which is to be transmitted from one station and received simultaneously at a number of other stations.

For example, let the two stations in Fig. 9 represent Baltimore and Philadelphia, the terminal stations at Washington and New York being arranged in precisely the same manner as the terminal station in Fig. 8. By this arrangement two simultaneous communications may be sent, say from Washington, each of which may be received independently at Baltimore, Philadelphia, and New York, while either of these stations may interrupt the senders at pleasure by operating their pole-changing transmitters  $t_1 t_1$ .

Fig. 10 shows a method of combining my improved receiving apparatus with the bridge duplex method described in Letters Patent of the United States, No. 132,932, granted to Joseph B. Stearns on the 12th of November, 1872, and reissued on the 22d of June, 1875, (No. 6,508.) In this case either the arrangement of the batteries and transmitting apparatus shown in Figs. 5 and 6, or that shown in Fig. 7, may be employed. The wire 36, leading from the transmitting apparatus, divides into two branches, 37 and 38, the former leading to the main line  $L$  through the rheostat  $V$ , and the latter to the artificial line  $A$  through the rheostat  $V_1$ . The arrangement of the rheostat  $R$  and condenser  $C_1$  in connection with the artificial line is fully set forth in the hereinbefore-mentioned patents of Joseph B. Stearns, and therefore need not be further described. In this case I prefer to construct each of the helices  $M M_1$  of the receiving-instrument in two divisions, the left-hand division of  $M$  and the right-hand division of  $M_1$  being included in the circuit of the bridge-wire 39 40. A rheostat,  $R_2$ , is placed in the bridge-wire between the receiving-instrument and the artificial line. The incoming current, being partially obstructed by the rheostat  $R_2$ , flows through the wires 42 and 41, and charges the condenser  $C$ . At the instant a reversal takes place the condenser is discharged through the wires 41 and 42, passing through the right-hand division of the helix  $M$  and the left-hand division of the helix  $M_1$ , and thus hastening the action of the reverse current from the distant

station upon the armature  $a$ , by which means the signals, especially upon long lines, are materially improved.

I claim as my invention—

1. A receiving-instrument having one armature so arranged as to respond to changes in the strength and in the polarity of the line-current, either or both, in combination with two independent sounding or recording instruments.

2. Two independent keys or transmitters in combination with a receiving-instrument having one armature so arranged as to respond to changes in the strength and in the polarity of the line-current, either or both, and two independent sounding or recording instruments.

3. Two independent keys or transmitters, so arranged with reference to each other and to a main battery or batteries that their separate and combined action is capable of producing four distinct electrical conditions in the main line, differing from each other in respect to the strength or polarity of the current, or both, in combination with a receiving-instrument, having one armature so arranged as to be capable of being placed in four different positions, corresponding, respectively, to the four electrical conditions of the main line and two independent sounding or recording instruments.

4. A key or device for transmitting signals by changing the polarity of the line-current, and an independent key or device for transmitting signals by changing the strength of the line-current, in combination with a receiving-instrument having one armature so arranged as to respond to changes in the strength and in the polarity of the line-current, either or both, and two independent sounding or recording instruments.

5. A key or device arranged to transmit signals by reversing the polarity of the normal main-line current, in combination with a second key which, when depressed, transmits a signal by diminishing or weakening the normal current, irrespective of the polarity of said current.

6. In a receiving-instrument, a polarized armature, acting upon two movable contact-levers, one of which presents a contact-point and the other an insulating-point to the said armature or its extension, in combination with stops which serve to limit the movement of each of the said contact-levers in each direction.

7. The vibrating lever  $t$  of a pole-changing transmitter, in combination with the contact-springs  $f$  and  $g$ , mounted upon a fixed support, and the adjustable stops  $h$  and  $i$ , substantially as and for the purpose specified.

In witness whereof I have hereunto set my hand this 9th day of February, A. D. 1877.

GERRITT SMITH.

Witnesses:

FRANK L. POPE,  
WM. ARNOUX.