

T. STROBRIDGE.

TOOL-HOLDER.

No. 189,282.

Patented April 3, 1877.

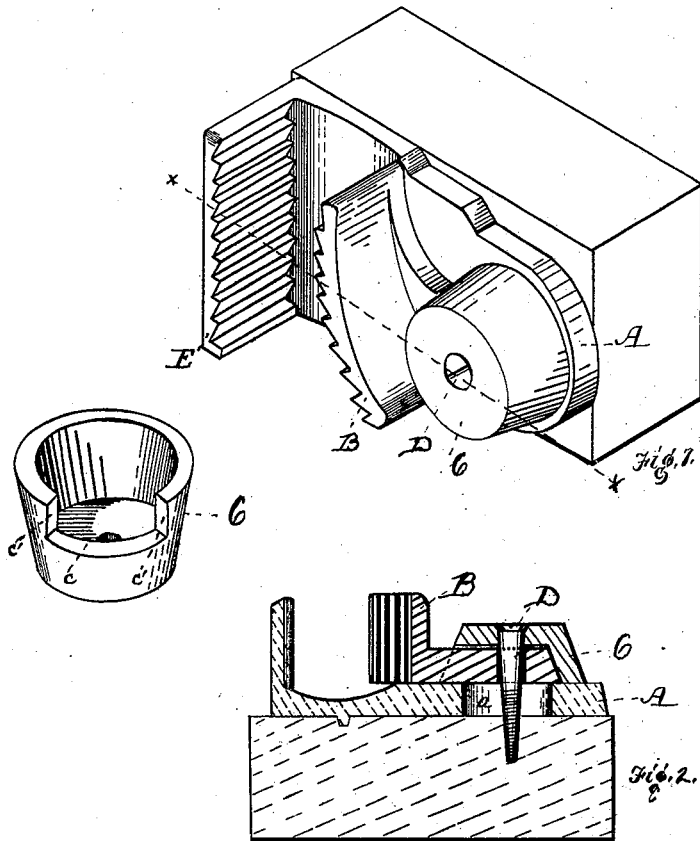

Witnesses.

James G. Bakewell
S. C. Fetter

Inventor.

Turner Strobidge
by Bakewell & Fetter
Attys

UNITED STATES PATENT OFFICE.

TURNER STROBRIDGE, OF NEW BRIGHTON, PENNSYLVANIA.

IMPROVEMENT IN TOOL-HOLDERS.

Specification forming part of Letters Patent No. **189,282**, dated April 3, 1877; application filed January 24, 1877.

To all whom it may concern:

Be it known that, **TURNER STROBRIDGE**, of New Brighton, in the county of Beaver and State of Pennsylvania, have invented new and useful Improvements in Devices for Holding Tools and other articles; and I do hereby declare the following to be a full, clear, and exact description thereof, reference being had to the accompanying drawing, forming a part of this specification, in which—

Figure 1 is a perspective view of my improved holder; and Fig. 2, a horizontal section through the line *x x*, Fig. 1.

My invention consists of an improved holder for holding various articles, such as brooms, tools, fire-irons, &c.

I will now proceed to describe my invention, so that others may manufacture and use the same.

Like letters refer to like parts wherever they occur.

A is a plate, in which is a slot, *a*, and upon which is a bar, E. B is a dog or cam, one end of which is shaped in the form of an arc of a circle. The face of this cam may be roughened, to enable it more effectually to gripe the article to be held. Through the other end of the cam passes the screw D in such manner as to allow the gripping end of the cam to move freely up and down.

C is an adjustable cap, which has an opening, *c*, in its side, through which passes the cam or dog B. The sides *c'* of the cap, on each side of the opening *c*, act as stops or rests for the cam or dog B.

D is a screw, which fastens the several parts together. E is a bar, which may have its inner surface roughened. It may be cast in the same piece as the bar A, as shown in the drawing, or it may be cast as a separate piece and fastened to the plate, or to the wall at any convenient distance from the cam or dog B.

The plate A, (on which is the bar E,) one

end of the cam B, and the cap C, are fastened together by the screw D, which passes through them, and which also screws into the wall or into a block or strip of wood, which can be fastened to the wall. The screw D thus holds the cap C firmly onto the plate A, and thus secures the end of the cam B, which is pivoted on the said screw.

The holder being fastened together, the article to be held is pushed up between the cam B and the bar E. The end of the cam moving up allows the ingress of the article to be held, but when the support of the hand is removed from the article, and its weight gives it a tendency to drop, the cam B and the bar E gripe the article and hold it firmly. The article may be readily released by raising the cam.

The cap C may be moved backward or forward on the plate A by moving the screw D in the slot *a*, so as to increase the capacity of the holder, or the same result may be attained by loosening the cap C and sliding the slotted plate A, on which is the bar E.

Having thus described my invention, what I claim, and desire to secure by Letters Patent, is—

1. The combination of the rest, the plate slotted as at *a*, the cam or dog, the cap, and a fastening device, substantially as and for the purpose specified.

2. The combination of the rest or bar, the cam or dog, and the slotted cap, substantially as and for the purpose specified.

3. The combination of the slotted plate, the rest, the cam or dog, and the slotted cap, substantially as and for the purpose specified.

In testimony whereof I, the said **TURNER STROBRIDGE**, have hereunto set my hand.

TURNER STROBRIDGE.

Witnesses:

G. W. GLASS,
HIRAM REED, Jr.