

O. D. GOODELL.

MACHINE FOR COMPRESSING BARRELS.

No. 189,309.

Patented April 10, 1877.

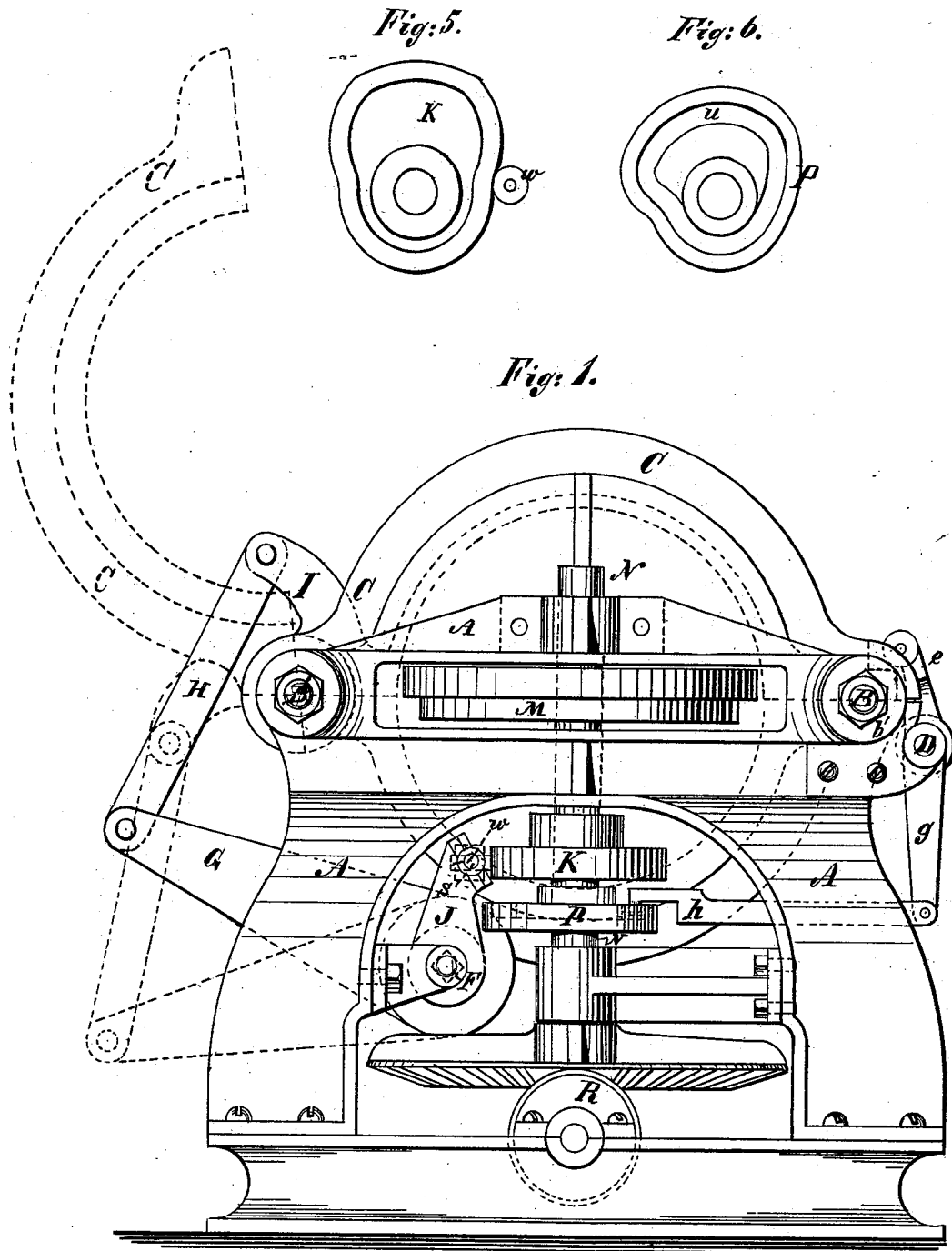

Witnesses:
Henry Eichling
C. S. Clark

Inventor:
O. D. Goodell

O. D. GOODELL.

MACHINE FOR COMPRESSING BARRELS.

No. 189,309.

Patented April 10, 1877.

Fig: 2

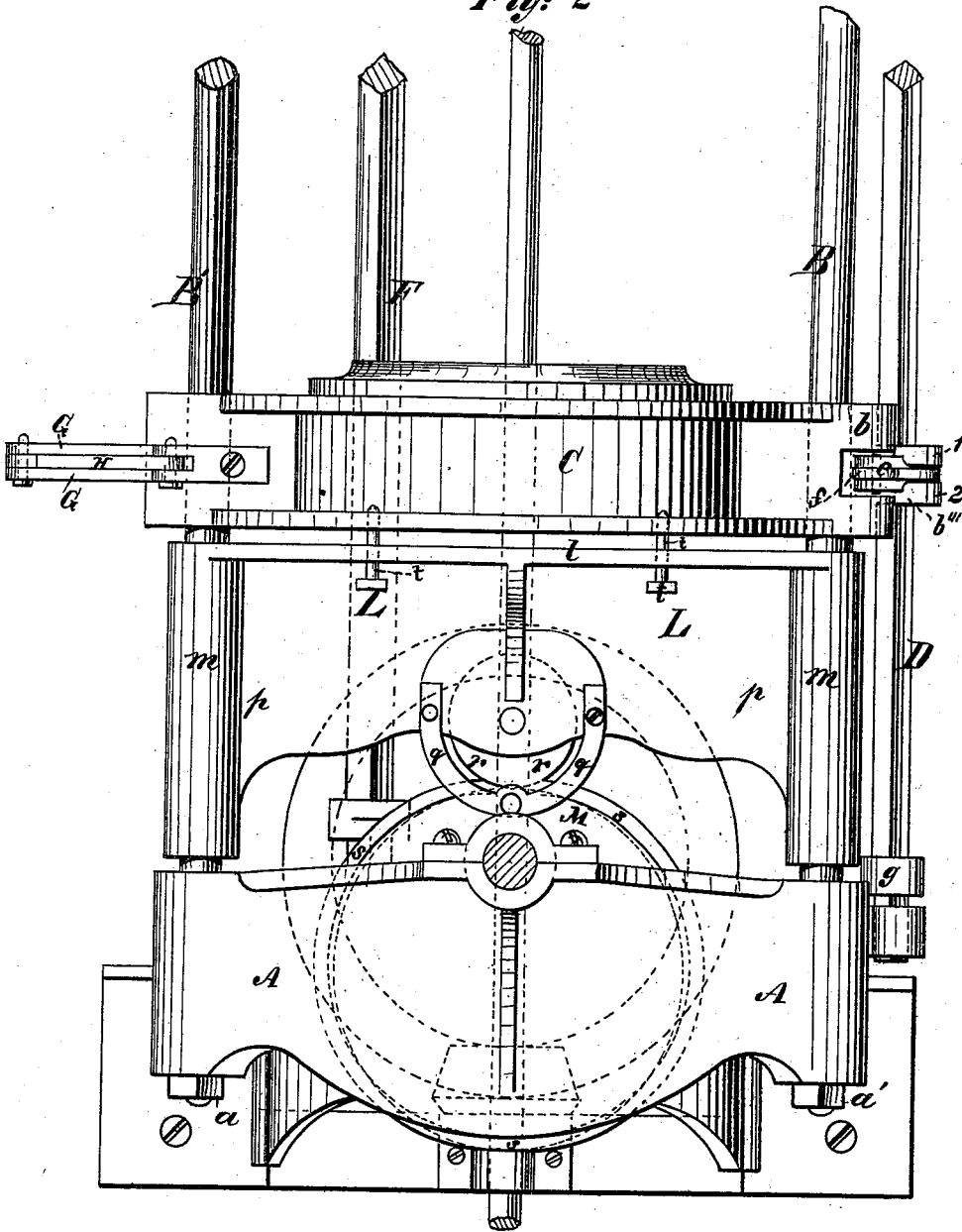

Witnesses:
Henry Eichling.
B. G. Clark.

Inventor:
Oliver D. Goodell.

O. D. GOODELL.

MACHINE FOR COMPRESSING BARRELS.

No. 189,309.

Patented April 10, 1877.

Fig. 3

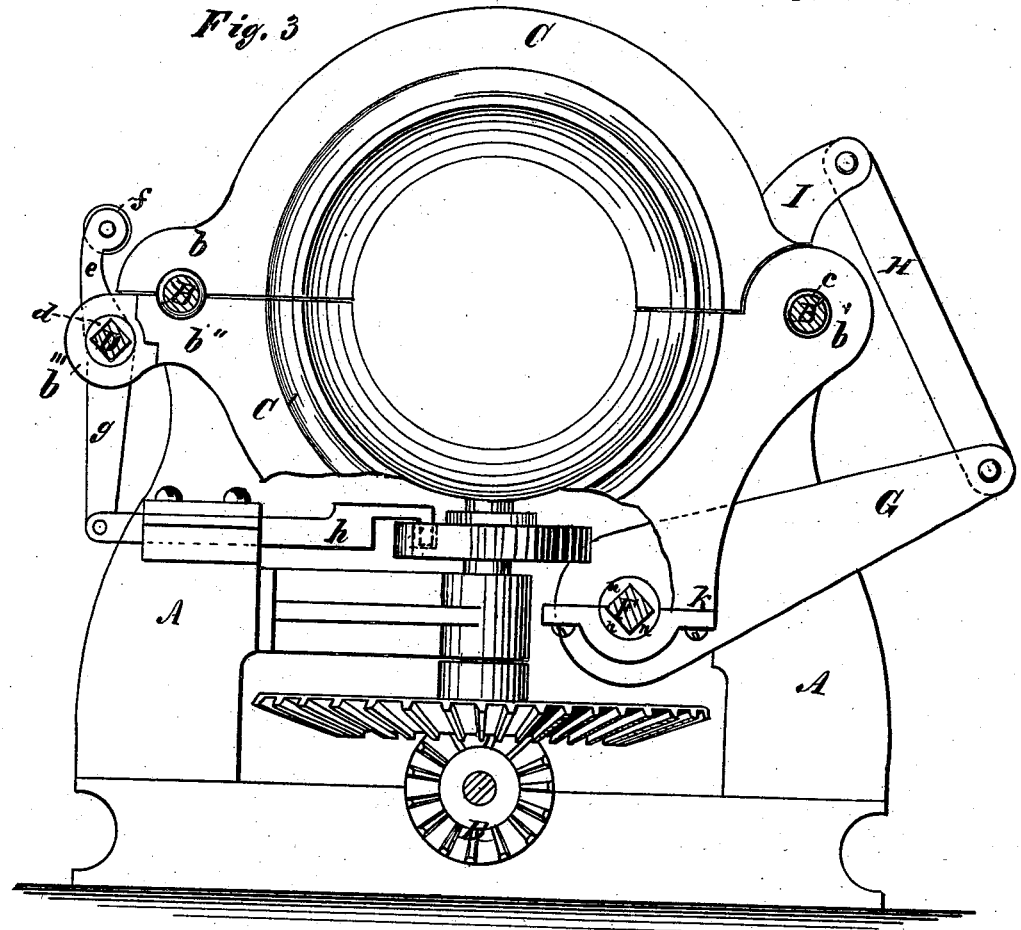
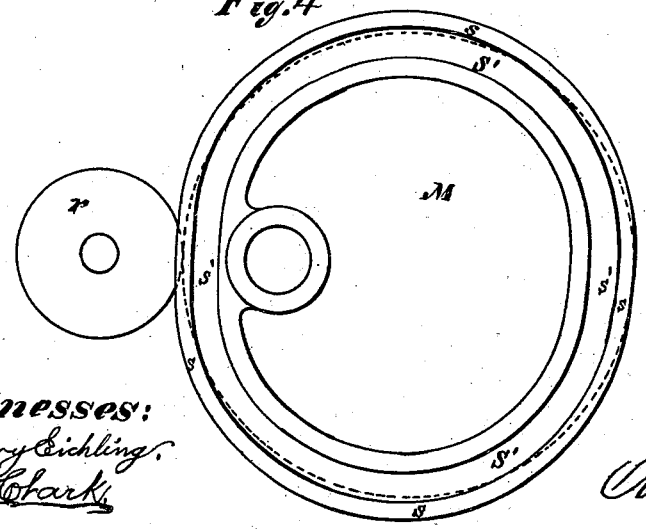

Fig. 4



Witnesses:
Henry Eichling.
B. E. Clark.

Inventor:
Olive D. Goodell

UNITED STATES PATENT OFFICE.

OLIVER D. GOODELL, OF ST. LOUIS, MISSOURI, ASSIGNOR TO THE UNITED STATES BARREL AND STAVE COMPANY, OF NEW YORK, N. Y.

IMPROVEMENT IN MACHINES FOR COMPRESSING BARRELS.

Specification forming part of Letters Patent No. 189,309, dated April 10, 1877; application filed October 1, 1875.

To all whom it may concern :

Be it known that I, OLIVER D. GOODELL, of the city of St. Louis, county of St. Louis, State of Missouri, have invented certain new and useful Improvements in Machines for Compressing Barrels, of which the following is a specification, reference being had to the accompanying drawings, forming part thereof.

Figure 1, Sheet 1, is an end elevation of a machine containing my improvements. Fig. 2 is a plan of one-half of my machine. Fig. 3 is a vertical cross-section of same. Figs. 4, 5, and 6 are face views of the series of cams used to impart motion to several parts of the machine.

My invention relates to a machine for compressing the ends of barrels, kegs, and other similar articles; and consists in the devices and their combinations, hereinafter described, whereby the dies employed to compress the barrel are automatically opened and closed, locked and unlocked, and moved onto and off from the barrel; also arranging the machine so that the center of the dies for compressing the barrel, the cams which move the dies, and the side beams or bars of the machine which take the strain from the action of the cams, are all in the same horizontal plane, whereby the force employed in compressing a barrel, being exerted in the plane of the said side bars, has no tendency to twist or spring the frame of the machine.

The working parts of this machine are mounted upon a heavy strong iron frame, consisting of end pieces, only one of which is shown in the drawings, (marked A,) as only one-half of the machine is represented, the other half being a duplicate of the one shown. These ends are connected together by strong iron bars B B', which pass through them, and are held by heavy nuts a a'. C C' are the two sections of the die by which the barrel is compressed. They have on either side of the dies strong ears or projections, indicated by the letter b, by which they are jointed together on one side at b', the round bar B' passing through such joint. This joint has a sleeve, c, fixed therein, thus forming a hollow joint, permitting the dies to slide back and forth on the bars B B'. Upon the opposite side the

projection b lies down upon the projection b'' when the die is closed, as seen in Fig. 3, an aperture for the bar B being made one-half in each section. This joint is also provided with a sleeve, made fast to the lower section C', through which passes the bar B, leaving the upper section C free to swing upon its hinges. D is a shaft, having round bearings at the ends in the end pieces A of the frame, in which it may rock. It passes through the ear or projection b''', the said projection being also provided with a sleeve, d, arranged to rock in said projection with the shaft D. The projection b'''' is forked, and between the divisions 1 and 2 works a latch-lever, e, which is fixed upon the sleeve d, so that while the projection b'''' of the lower section C' of the die may slide back and forth on the shaft D, the said shaft may rock within the said projection, and carry with it the said latch-lever. The upper end of this lever is bent over toward the dies, forming substantially a hook, which, for the purpose of relieving friction, is provided with a friction-roller, f. A notch is formed on the upper surface of the projection b, which the latch-lever engages, when swung inward, thereby locking the dies together.

A forked projection, k, is formed on the under side of the lower section C' of the dies. F is a shaft rocking in bearings in the ends A of the frame. A bearing is also provided for it in the projection k. This bearing is provided with a sleeve, n, which slides on the shaft F, and rocks in the said projection. Upon this sleeve, and between the forks or divisions of the projection k, is fixed a lever, G, which is connected by the link H to the arm I, formed on or secured to the upper face of section C of the die, near its hinge. Upon the shaft F is fixed the lever J, the upper end of which engages with a cam, K, to be more particularly described presently. This lever J is preferably formed of two separate arms, fixed upon the shaft, with a cross-bar between their upper ends, in which is placed a friction-roller, w, that is in contact with the said cam K.

L is a sliding frame, formed of a broad plate, l, which covers the outer-end face of the die, and the sleeve-arms m m, fitted to slide

upon the bars B B', and a strong web, *p*, extending across between the said arms.

M is an eccentric wheel or cam, fixed on the vertical shaft N, constructed and operating to throw the sliding frame L toward the dies, and push the dies before said frame toward the center of the machine. A friction-pulley, *r*, mounted in the web *p* of the frame L, takes the pressure of the eccentric M.

Upon the upper face of the eccentric is a projecting flange, *s*. An arm, *g*, (preferably semicircular, as shown in the drawings,) extends over onto the upper face of this eccentric, from which projects a stud or pin within the flange *s*, whereby the frame L is drawn back by the throw of the eccentric away from the center of the machine, bringing with it the dies, they being connected to the plate *l* by means of the bolts *t t'*, but in such a way as to permit a little lost motion, the object of the lost motion being to permit the die to be unlatched by the reverse motion of the cams before the opening of the dies commences.

P is another cam, fixed also upon the shaft N, upon the upper face of which is an irregular groove, *u*. (Shown plainly in Fig. 6.) The inner end of the arm extends over upon the upper face of this cam, from which a pin or stud projects downward into the said groove. This cam acts, through the arm *h* and lever *g*, to rock the shaft D.

The shaft N has its bearings in the end of the frame A, the upper cross-beam of which is recessed, as shown, and the cam or eccentric M works in this recess, thus bringing the said cam into the same plane with the side bar B and the center of the dies, with a bearing for shaft N above and below the said recess.

I am aware that machines have been made for compressing barrels; but so far as I know, the opening, closing, locking, and unlocking the dies has, in such machines, been performed by hand, or by mechanism separate from that which presses the dies onto the barrels, set in motion by the hand and volition of the operator. My improvement is limited to the devices and combinations in the machine described, by which all the movements required to open, close, lock, and unlock the dies and draw them back after the act of compression is performed, are derived from the same source of motion, so that they shall act automatically and in mechanical co-operation with each other, and perform all the necessary operations without the intervention of an attendant operation.

The operation is as follows: The vertical shaft N receives motion through the bevel pinion R, thus transmitting it to the series of cams P, K, and M.

The cam M, revolving against the friction-roller *r*, carries forward the follower plate L and dies C C' to the full length of stroke. Upon the return, the roller *r*, acting in the irregular groove *s'*, Sheet No. 2, carries the whole back to its starting point.

Simultaneously the cam P, acting upon the arm *h*, which is attached to the shaft D, acts to rock the said shaft, and thus to move the latch *e* forward, thus securing or latching the dies C when closed. During the process of compression the cam P is acting through the true arc of its longest radius, and at the completion of the process the irregular groove, acting at the proper time, carries the arm *h* inward toward its original position, thus swinging off the latch *e* and unlocking the dies. The latch *e* rocks with and slides freely on the bar D, to conform to the rectilinear motion of the dies.

At the completion of the compression, (the latch having been thrown off, as described,) the cam K commences to act upon the roller *w*, throwing back the lever J; the lever J, acting upon the bar F, motion is transmitted through the lever G, links H, and arm I to the section of the die C, and it is thus opened sufficiently to remove the now completed barrel, as represented by the dotted lines in Fig. 1. As the cam K is now acting through the true arc of its longest radius, the dies remain open until they are nearly, or quite, drawn back, when the process is resumed for the next succeeding barrel.

The lever G rocks with the shaft F in boxes attached to the projection *k*, and slides freely upon the shaft F, and thus is also allowed to conform to the rectilinear motion of the dies, the dies being hinged on the sleeve *c*, the bar B being passed through the sleeve, securing freedom of action to the hinge, and at the same time allows the dies to slide freely on the bar B.

I do not confine myself to the precise arrangement shown and described, as my improvement can be applied to a perpendicular as well as to a horizontal machine.

The several cams may be actuated by separate shafts, either parallel or transverse, deriving their motion from the same driving-shaft, and the cams so placed as to communicate their respective motions directly to the several levers; but I adopt the plan shown, for simplicity of construction. The dies may be opened and closed by links, attached to the front or latch side, by means of an equivalent-timed cam; but I adopt the plan shown for speed and convenience of operation.

An equivalent for the square shafts F and D may be found in round shafts, provided with elongated key-seats or feathers, in order to communicate to the levers the necessary rocking motion, at the same time allowing them to slide freely, in order to conform to the rectilinear motion of the dies; or the bars may be oval, or have any number of parallel sides, or be of any irregular form of section, for the purpose here described.

The cams P K M may be made to operate against stationary or fixed points or surfaces; but I prefer to use the friction-rollers in them to avoid friction.

What I claim is—

1. The combination, in a barrel-compressing machine, of the dies C C', with the cam K, the levers J G I, arm H, and shaft F, whereby the said dies are automatically opened and closed, and the shaft N, cam M, having the flange s, the follower-plate L, and arm q, whereby a reciprocating movement is given to the said dies, substantially as described.

2. The combination, in a barrel-compressing machine, of the sectional dies described with the cam P, the web p, the lever g, and latch e, whereby the said dies are automatically locked and unlocked, as described.

3. The combination, in a barrel-compressing machine, of the sectional dies C C', the follower-plate L, the cam M, the groove s', arm or bracket q, and bolt t, as and for the purpose described.

4. The combination, in a barrel-compressing machine, of the sectional dies C C', follower-plate L, and the cam M, provided with the groove s', the arm or bracket q, and the bolt t', all constructed to operate as and for the purpose specified.

5. The combination, in a barrel-compressing

machine, of the sectional dies C C', the guide-bar B, and the hollow sleeve hinged joint b e, as and for the purpose described.

6. The combination, in a barrel-compressing machine, of the cam P, the latch e, the shaft D, the forked projection b''', and the sleeve d, as and for the purpose described.

7. In a barrel-compressing machine, the construction and arrangement described of the side bars B B', the cam M, in the same plane with the center of the dies, the shaft of said cam having bearings above and below said plane, as and for the purpose described.

8. The combination, in a barrel-compressing machine, of the sectional dies C C', the reciprocating follower-plate or frame L, connected to said sectional dies, as specified, and the cam K, levers J, G, and I, and arm H, acting to open and close the dies, as described.

Witness my hand this 30th day of September, 1875.

OLIVER D. GOODELL.

Witnesses:

B. S. CLARK,

A. S. FITCH.