

J. LEITCH.
CORN-PLANTER.

No. 189,315.

Patented April 10, 1877.

Fig 1.

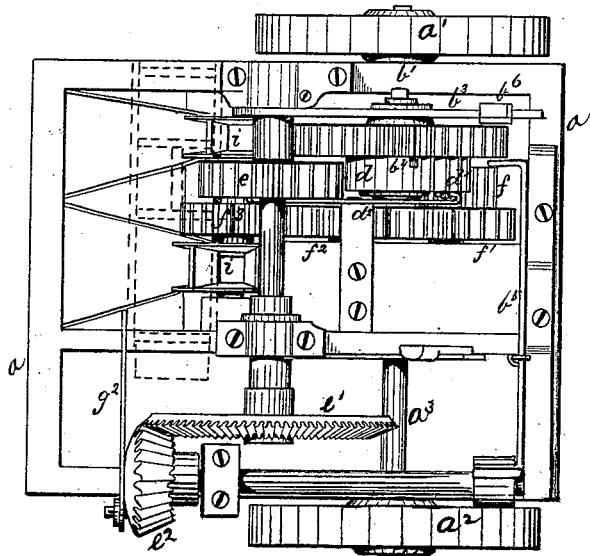
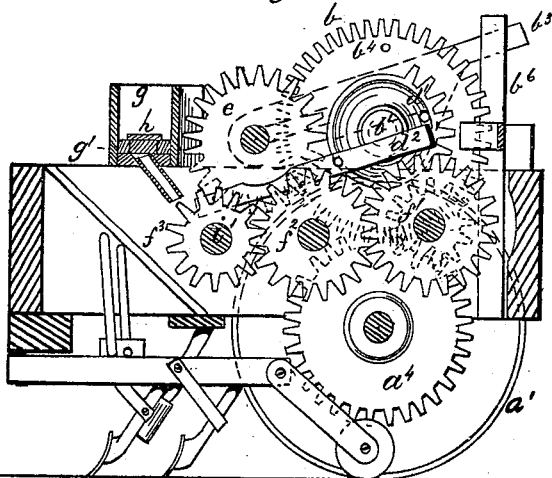

Fig 2.



Witnesses
B. C. Pole
R. H. Lacey.

Inventor.
John Leitch
Per R. H. & A. T. Lacey
attorneys

J. LEITCH.
CORN-PLANTER.

No. 189,315.

Patented April 10, 1877.

Fig 3.

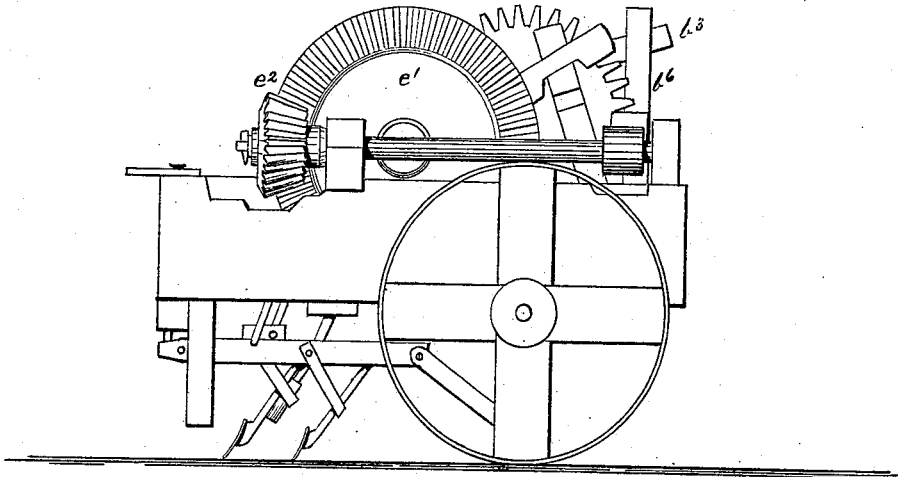
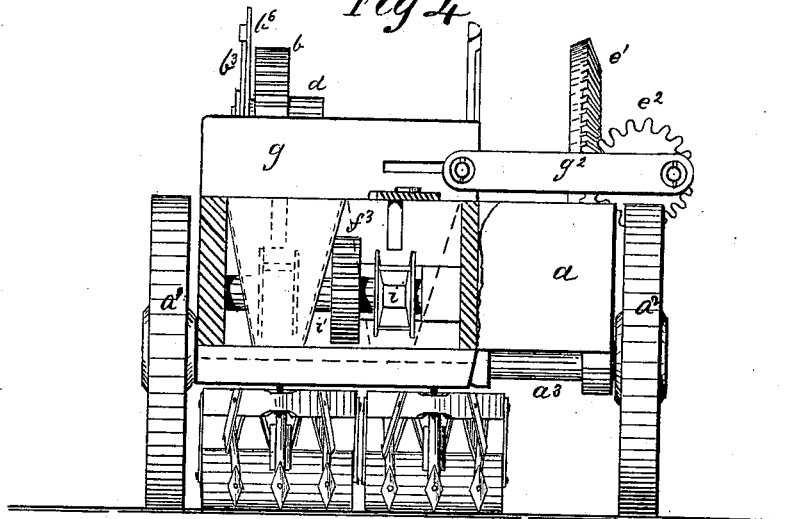

Fig 4



Witnesses.
 B. C. Pole
 R. H. Lacey.

Inventor.
 John Leitch
 Per Robt A. Lacey
 attorney.

J. LEITCH.
CORN-PLANTER.

No. 189,315.

Patented April 10, 1877.

Fig 5.

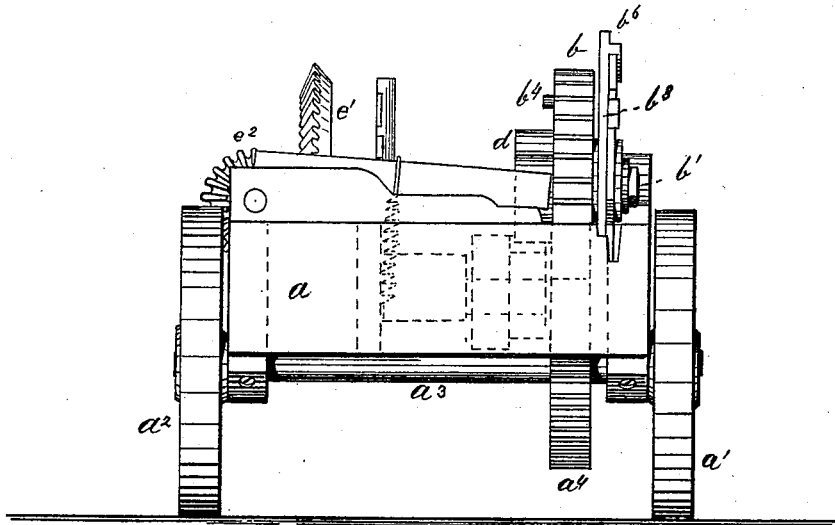

Fig 6.

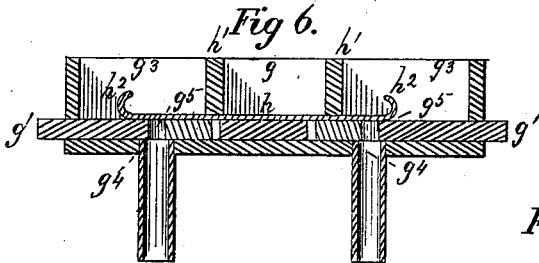
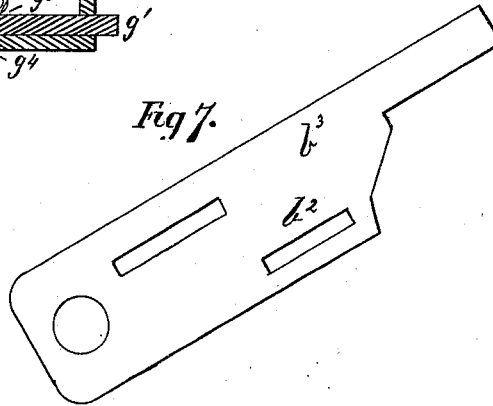

Fig 7.



Witnesses.
B. C. Pole
R. H. Lacey

Inventor.
John Leitch,
Per R. H. Lacey
attorney.

UNITED STATES PATENT OFFICE

JOHN LEITCH, OF BLACK EARTH, WISCONSIN.

IMPROVEMENT IN CORN-PLANTERS.

Specification forming part of Letters Patent No. **189,315**, dated April 10, 1877; application filed November 21, 1876.

To all whom it may concern:

Be it known that I, JOHN LEITCH, of Black Earth, in the county of Dane and State of Wisconsin, have invented certain new and useful Improvements in Corn-Planters; and I do hereby declare that the following is a full, clear, and exact description thereof, which will enable others skilled in the art to which it pertains to make and use the same, reference being had to the accompanying drawing, and to the letters of reference marked thereon, which form a part of this specification.

My invention relates to improvements in corn-planters, and has for its object to provide a substantial machine which will drop the grain with regularity and in rows which may be cultivated both ways.

It consists in an index-wheel to which is attached a segmental wheel, which is arranged to engage alternately with two sets of gearing which connect with and operate the dropping devices, and in other mechanism, all of which are constructed and arranged to operate in the manner hereinafter fully explained.

In the drawings, Figure 1 is a plan. Fig. 2 is a longitudinal vertical section. Fig. 3 is a side elevation. Figs. 4 and 5 are, respectively, front and rear elevations, with portions of the frame removed. Fig. 6 is a longitudinal section of the feed-box; and Fig. 7 is the swinging or pivoted bar or lever for supporting and regulating the position of the index and segmental wheels, and for throwing the machine out of and in gear.

a is the main frame, supported and carried by the wheels *a*¹ *a*², affixed on the revolving axle *a*³, journaled in bearings on the under side of said frame. *a*⁴ is the master or driving gear-wheel, which is fixed on and revolves with the axle *a*³.

b is the index-wheel. It is supported by and revolves on a bolt or axis, *b*¹, which is secured with capability of adjustment in the inclined slot *b*² in the hinged or pivoted supporting-bar *b*³. It is engaged and revolved by the master-wheel *a*⁴, and revolves one complete revolution in the movement of the machine—the distance between two adjacent hills or rows. It will be seen that its circumference indicates the distance apart at which the hills

are to be planted, and that by employing index-wheels of different sizes the hills may be dropped at any desired distance apart. It is provided with a stud or pin, *b*⁴, standing out from its face, and so arranged as to engage with the end of a rocking arm or pawl, *b*⁵, which is pivoted to the frame *a*, and arranged to engage with a ratchet or stop on the axis of one of the operating-gears, hereinafter described. The stud will disengage the pawl, so that the gearing can revolve.

The bar *b*³ has its lower or forward end pivoted to the frame *a*, while its rear end may be raised or lowered and secured in suitable notches in an adjustable standard, *b*⁶. The slot *b*² is so formed and arranged as to permit the setting back or forward therein of the axial pin *b*¹, and thereby adapt the latter to receive larger or smaller index and segmental wheels, as may be required.

d is a segmental wheel. It is made separate from, but is connected by a suitable clutch with and is operated by, the index-wheel *b*, with which it revolves simultaneously. It is provided on its face with a stud, *d*¹, arranged to engage the rear end of the lever or pawl *d*², the forward end of which extends to and is adapted to engage and stop the revolution of the axis on which the dropping hoppers or boxes are placed. In its revolutions it engages alternately with the pinions *e* and *f*, which, by means of intermediate gear-wheels, causes the alternate operation of the slide-valve in the feed-box and the dropping-hoppers.

The revolution of the pinion *e* communicates motion to the bevel-gears *e*¹ *e*², which operate the seed-slide *g*¹ in the feed-box *g* by means of the connecting-rod or pitman *g*². The extended axis of the bevel crank-wheel *e*² is formed with a suitable stop or ratchet to engage the end of the lever or pawl *b*⁵, which, at the proper moment, stops the further revolution of wheels *e*¹ *e*², and, consequently, the further movement of the slide-valve *g*¹. The segmental wheel *d* and the wheels *e*¹ *e*² are so constructed with reference to each other that with each complete revolution of the first, a complete revolution is given to the last, thereby giving a complete movement outward and back of the

seed-slide g^1 , which movement discharges the requisite amount of grain from the feed-box into the droppers below.

The feed or grain box g is, by preference, divided into two compartments, $g^3 g^3$, by one or more partitions, h^1 , between the under edges of which and the bottom of the box is left a sufficient opening or space to admit the insertion and free reciprocating movement of the seed-slide g^1 . It is provided with the discharge-tubes g^4 , placed at or near the center of the bottom of the compartments g^3 , which tubes conduct the grain to the droppers underneath. It has the under portion of the end boards cut away, so as to provide suitable openings, which afford facilities for the free reciprocating movement of the seed-slide.

The seed-slide g^1 is provided with openings g^5 , which receive and regulate the quantity of grain to be delivered from the grain-box at each movement of the seed-slide. It rests flat on the bottom of the box, and fits neatly the spaces under the partitions h^1 and in the ends of the grain-box, so that no grain can escape from the compartments.

$h h$ are the cut-offs, arranged one in each compartment. They are straight on their under sides, and lie flat upon the upper side of the seed-slide g^1 . Their outer ends are secured rigidly to the under edges of the partitions h^1 , while their inner ends extend slightly beyond and over the discharge-tubes g^4 , and are turned up, as shown at h^2 , to prevent them from cutting or cracking the grain, and to facilitate the movement of the seed-slide. They are made of spring or other elastic metal, so that they will spring or bend upward, and thereby adjust themselves to the different sizes of grains of corn, and, at the same time, exert a positive pressure or action downward, and thus prevent the drawing under them by the seed-slide of more grain than can be contained in the openings g^5 . Where cut-offs held down by their own gravity and the weight of the grain, or other cut-offs of ordinary construction, are employed, it frequently occurs that the grains of corn will be drawn with such force against the turned-up ends as to force them upward, and thereby permit more grain to be drawn under than is contained in the openings g^5 , and often in such cases the grains of corn will be forcibly rolled over and over between the seed-slide and cut-off, and cracked and broken. These difficulties are entirely obviated by my improved spring cut-off.

The droppers $i i$ are fixed on and revolve with the axis i' of the pinion f^3 , and they are placed under and in such position as to receive the grain from the feed-box. They are so connected, by means of the wheels f^3, f^2, f^1 , and f , with the segmental wheel d as to be revolved one full revolution with each movement of the machine the distance between two adjacent hills. They deposit the grain in the hills. The axis i' is provided with a suitable ratchet or stop to engage the end of the

lever d^2 , which, at the proper moment, engages with said stop and checks the revolution of the droppers, and holds the latter steadily in position below the feed-box.

It will be seen that my machine is adapted to drop two rows at a time, and that being set to drop the first hills in the proper place, the succeeding hills will be dropped at equal distances apart and with regularity.

The operation of the machine is as follows: The index-wheel being adjusted so as to cause the first hill to be dropped in the desired place, the machine is moved forward, and the segmental wheel clears the pinion f and immediately engages the pinion e . At the same time the stud b^4 actuates the lever b^5 , disengaging it from its hold on the axis of the wheel e^2 . The wheel e^2 is revolved by the segmental and intermediate wheels, causing the seed-slide g^1 to be thrown out and back, so that the openings g^5 may receive and carry the necessary grain and deposit it in the droppers. This being done, a brief period of time intervenes before the segmental wheel engages the pinion f , during which time the operator may see the corn in the droppers, and can know whether the proper quantity is being dropped. As soon as the wheel d has cleared the pinion f , the lever b^5 engages and stops the revolution of the wheel e^2 .

The stud d^1 comes now in contact with the lever d^2 , and disengages the latter from its hold on the axis i' , and immediately the segmental wheel engages the pinion f , and causes the revolution of the axis i' by means of the intermediate wheels, so that the droppers $i i$ are turned one complete revolution, depositing the grain in the hills, and stopping in position immediately under the feed-box, when the segmental wheel has cleared the wheel f . The lever d^2 immediately engages with the axis i' , and the segmental wheel immediately engages with the wheel e , and the stud d^1 with the lever d^2 , and the operation first described is repeated.

By this double operation the corn is not only dropped regularly and at equal distances apart, but the operation may be inspected as it proceeds.

The standard b^6 has its lower end slotted, and may be set higher or lower to adapt it to hold the lever or bar b^3 when different-sized wheels are employed.

Having described my invention, what I claim, and desire to secure by Letters Patent, is—

1. The combination, with the index-wheel b , having a stud, b^4 , and the seed-slide g^1 in the feed-box g , of the segmental wheel d , lever b^5 , gears $e e^1 e^2$, and pitman g^2 , substantially as and for the purpose set forth.

2. The combination, with the index-wheel b and droppers $i i$, mounted on the axis i' , of the segmental wheel d , having the stud d^1 , lever d^2 , and gear-wheels f, f^1, f^2 , and f^3 , substantially as and for the purpose set forth.

3. In a machine for planting grain, the segmental wheel *d*, provided with stud or pin *d*¹, adapted to be attached to an index-wheel, *b*, and arranged to engage alternately with and operate the two sets of gearing which operate the gage-valve and dropping-hoppers, substantially as set forth.

In testimony that I claim the foregoing as my own I affix my signature in presence of two witnesses.

JOHN LEITCH.

Witnesses:

JAS. C. COWDERY,
BENJAMIN R. COMLAY.