

D. T. GILLIS.
TRACTION HORSE-POWER.

No. 189,354.

Patented April 10, 1877.

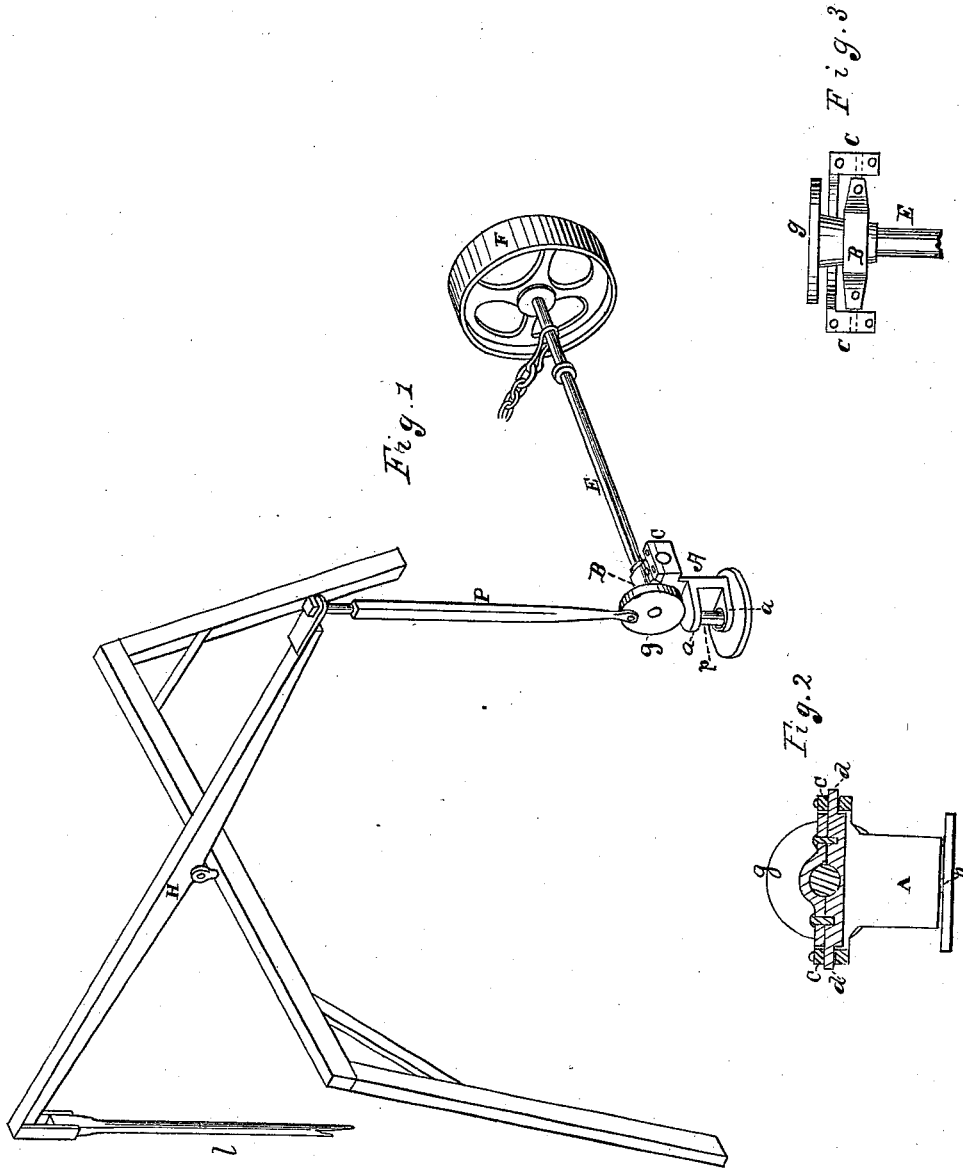

Witnesses
Geo. H. Strong
Jno. L. Boone

Inventor
David T. Gillis
by *Dawley & Co*
Attys

UNITED STATES PATENT OFFICE.

DAVID T. GILLIS, OF SAN LEANDRO, CALIFORNIA, ASSIGNOR OF ONE-HALF HIS RIGHT TO FRANK A. HILL, OF SAME PLACE.

IMPROVEMENT IN TRACTION HORSE-POWERS.

Specification forming part of Letters Patent No. 189,354, dated April 10, 1877; application filed March 1, 1877.

To all whom it may concern:

Be it known that I, DAVID T. GILLIS, of San Leandro, county of Alameda, and State of California, have invented an Improvement in Traction Horse-Powers; and I do hereby declare the following to be a full, clear, and exact description thereof, reference being had to the accompanying drawings.

The object of my invention is to provide an economical and effective means for operating pumps by horse-power; and it consists in a running-gear and pivoted bearings, constructed as hereinafter described, in combination with a walking-beam and rods, arranged to operate a pump-movement, substantially as hereinafter more fully set forth and claimed.

A is a standard or upright, arranged to rotate around a vertical pin, *p*. As shown in Figure 1, this pin passes up through the lower lug *a* to a bearing upon the under side of a similar lug or arm, *a*, at the upper end of the standard. At the upper end of the standard I also form two bearing-blocks, *c c*, in which the bearings or journals *d d* of a horizontally-arranged box, B, are mounted. This box is preferably composed of two parts, bolted or otherwise secured together, the lower part being constructed with the journals.

The axle E of the running-gear, which is arranged to be propelled around a fixed center by horse-power, is provided at one end with a traction-wheel, F. At the other end of the axle is a crank-wheel, *g*, for the purpose of giving an up-and-down stroke to the pitman P, which connects it with and operates the walking-beam H. The axle E has its bearing at or near the crank-wheel *g*, in the box B, at the upper end of the upright or standard A, which is pivoted at its base upon a pin, *h*, so as to turn freely around with the running-gear. The walking-beam H, which is supported by a suitable upright, also connects with the rod *l* of a pump-movement.

This machine is operated by horse-power. The horse is hitched to the axle E and is driven around a circle. The rotation of the traction-wheel causes the axle and crank-wheel to rotate, and thus communicates motion to the pump-rod.

By supporting the inner end of the axle in the journaled box B, the traction-wheel will always have a bearing, no matter how uneven the track may become by reason of wear.

By this construction it will also be noticed that the crank-wheel *g*, which is located over the pivotal center of the device, is mounted upon the traction-wheel axle, which passes through the pivoted journal-box B.

This machine can also be used for furnishing power for many purposes, and will be especially valuable as a cheap and effective farm power.

I am aware that circular-track horse-powers are not new, and that in this connection rocking bearings have also been employed.

What I claim, therefore, is—

In a traction horse-power, the pivoted standard A *a*, with blocks *c c* and journaled box B at its upper end, in combination with the traction-wheel and axle E thereof, which passes through the box B and is provided with a crank-wheel, *g*, said crank-wheel being connected with the walking-beam H by means of the pitman P, the said parts being constructed and arranged for operation substantially in the manner and for the purposes set forth.

In witness whereof I have hereunto set my hand and seal.

DAVID T. GILLIS. [L. s.]

Witnesses:

GEO. H. STRONG,
O. T. STACY.