

H. F. HANSON & F. O. BUZZELL.

EXERCISING MACHINE.

No. 189,356.

Patented April 10, 1877.

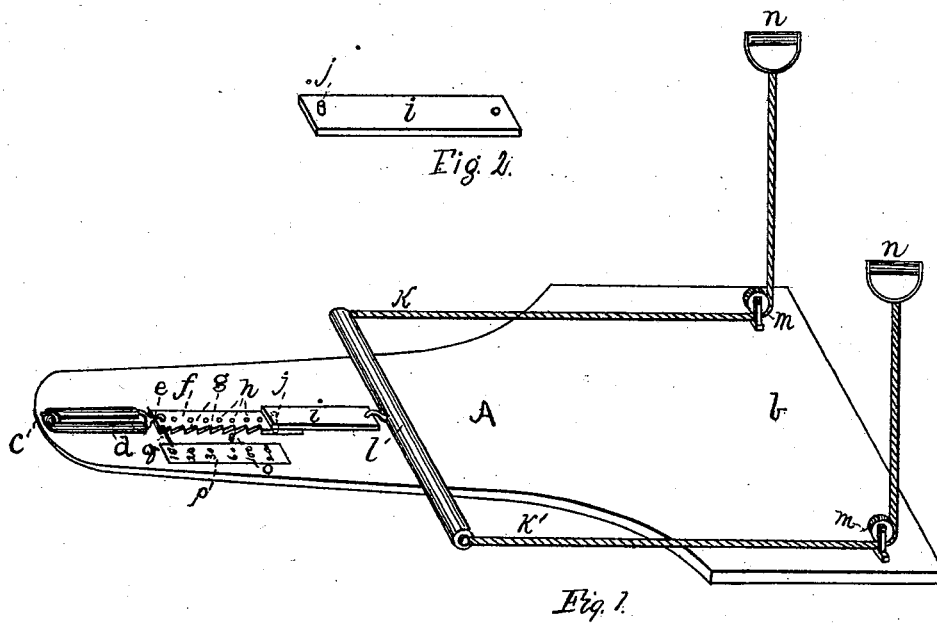

Witness
Charles H. Lynch
E. S. Feltus

Inventors
H. F. Hanson and
Frank O. Buzzell
Per O. W. Hankins, Atty.

UNITED STATES PATENT OFFICE.

HORACE F. HANSON AND FRANK O. BUZZELL, OF BANGOR, MAINE.

IMPROVEMENT IN EXERCISING-MACHINES.

Specification forming part of Letters Patent No. **189,356**, dated April 10, 1877; application filed February 10, 1877.

To all whom it may concern:

Be it known that we, HORACE F. HANSON and FRANK O. BUZZELL, both of Bangor, in the county of Penobscot, and State of Maine, have invented certain new and useful Improvements in Exercising Apparatus; and we do hereby declare that the following is a full, clear, and exact description thereof, that will enable others skilled in the art to which it appertains to make and use the same, reference being had to the accompanying drawings, forming a part of this specification, in which—

Figure 1 shows a perspective of our invention. Fig. 2 a bottom view of bar *i*.

Same letters show like parts.

The object of our invention is the production of an exercising apparatus or health-lift, which shall be portable, simple in construction, easily adapted to the varying strength of different users, and which can be afforded at a reasonable price.

Our invention will be readily understood by reference to the accompanying drawings. A shows a platform, upon which the operator stands at *b*. This platform may be mounted on casters, if desired. At one end, farthest from the operator is a hook, *c*, securing a heavy rubber or metallic spring, *d*, at the other end of which is a second hook, *e*, to which is attached a bar, *f*, having teeth or catches *g* on one side, and provided with perforations *h*. A second bar, *i*, provided with a stud, *j*, fitting these perforations, is attached at its other end to a cross-bar, *l*, from the ends of which cords *k k'* pass rearward through pulleys, and terminate in handles *n*.

To operate the machine, the user stands at *b*, as before stated, taking the handles *n*, and bending the knees slightly. The stud *j* being inserted in the first perforation *h* of the bar *f*—or for a short or long armed person, in the second or third, as may be necessary—the operator lifts upon the handles, drawing out the spring *d*. After reaching an upright position by a slight outward pressure upon one of the cords *k'* by the toe, the bar *f* is thrown to one side, its catch *g* engaging with a pin, *o*, in the platform of the machine, and holding the spring extended. The bar *i* is now readjusted by being moved forward, and its stud inserted in the next perforation of the bar *f*, shortening the cords *k k'*. The operator again resumes his position, and lifting on the

handles again extends the spring, this time meeting, of course, with increased resistance, and being obliged to exert more strength.

By continuing the process of lifting as above, greater resistance is met at each readjustment, and this can be still further regulated by using springs of different strengths. A scale, *p*, is also attached to the platform, and a pointer, *q*, secured to the bar *f* registers the amount of strength exerted at each lift in full view of the operator.

As before intimated by means of the bar *i*, with its stud *j*, and the perforations in the bar *f*, the apparatus may be adjusted to users of different heights.

What we claim as our invention, and desire to secure by Letters Patent, is—

1. In a health-lift, the combination of the lifting or extending devices, with a spring, *d*, and with both retaining and readjusting devices, said retaining devices holding the spring in extension, while the readjusting devices enable the cords to be taken up to compensate for the increased length of the spring, whereby the power necessary to extend said spring may be increased with each successive lift, substantially as and for the purposes described.

2. In combination with the spring *d*, the toothed bar *f* and pin *o*, holding the spring in extension, substantially as set forth.

3. In combination with the spring *d*, toothed bar *f* and pin *o*, holding the spring in extension, the perforations *h*, bar *i*, stud *j*, and lifting devices, adjustable substantially as and for the purposes set forth.

4. In a health-lift, in combination with the resisting-spring *d*, the bar *f*, and pointer *q*, moving with said spring and scale *p*, adjusted to show the strength exerted in extending said spring, as set forth.

5. In combination with the platform A, the spring *d*, toothed and perforated bar *f*, bar *i*, stud *j*, pin *o*, cords *k k'*, cross-bar *l*, pulleys *m* and handles *n*, arranged as herein described, for the purposes set forth.

In testimony that we claim the foregoing, we have hereunto set our hands this 6th day of February, 1877.

HORACE F. HANSON.
FRANK O. BUZZELL.

Witnesses:

JOHN R. MASON,
WM. FRANKLIN SEAVEY.