

G. W. HAYES.

ELASTIC HUB.

No. 189,357.

Patented April 10, 1877.

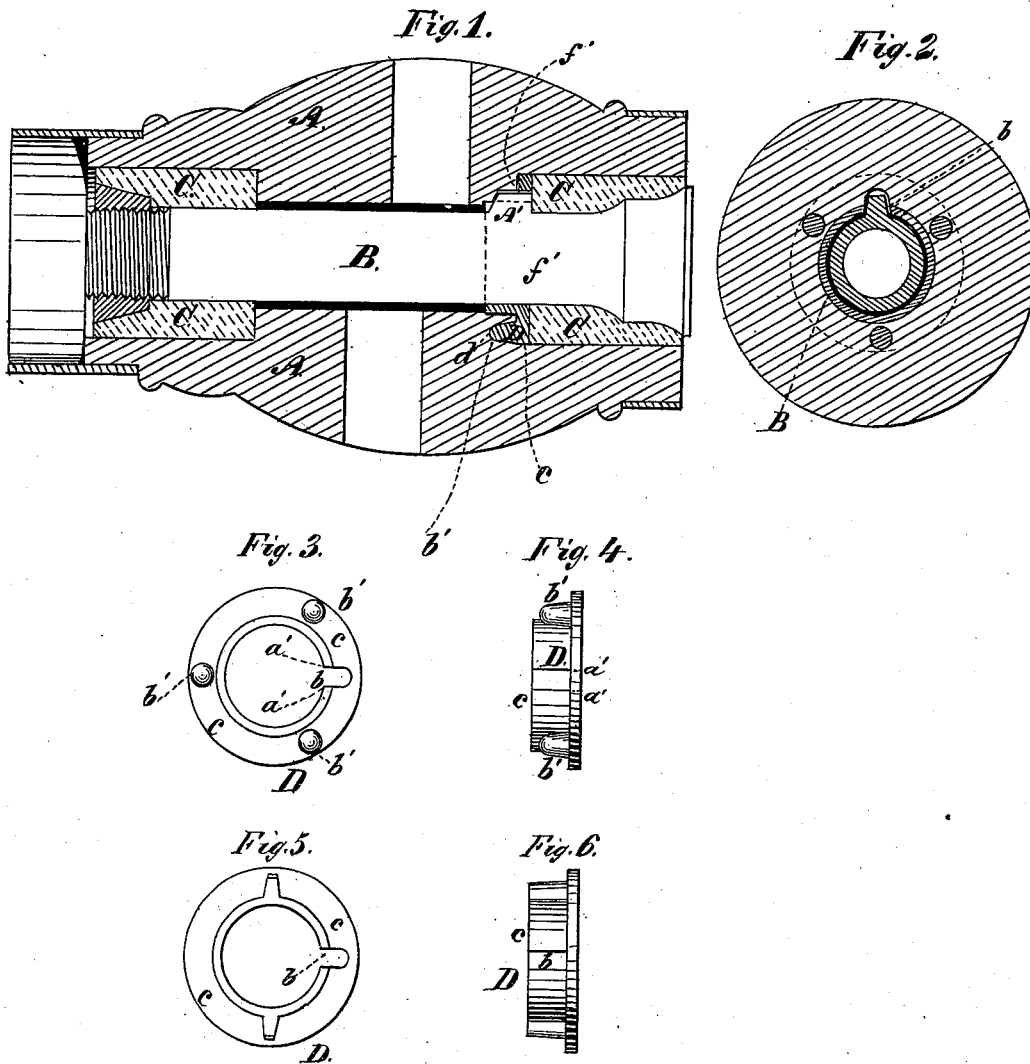

Witnesses:

Henry Leibling.
Edward Holly

Inventor:

George W Hayes
per James A Whitney
Atty.

UNITED STATES PATENT OFFICE.

GEORGE W. HAYES, OF NEW YORK, N. Y., ASSIGNOR TO JOHN B. SAMMIS,
OF SAME PLACE.

IMPROVEMENT IN ELASTIC HUBS.

Specification forming part of Letters Patent No. 189,357, dated April 10, 1877; application filed
January 4, 1877.

To all whom it may concern:

Be it known that I, GEORGE W. HAYES, of the city, county, and State of New York, have invented certain Improvements in Elastic Hubs, of which the following is a specification:

This invention relates to that class of hubs for wheels of vehicles in which a tubular box is sustained in one or more cushions, of india-rubber or equivalent elastic material, provided within the hub; and the object of this invention is to prevent the axial turning of the box, with reference to the hub, when, for any reason, the cutting of longitudinal grooves within the bore of the hub is objectionable; and to this end my said invention comprises a holding-ring of novel construction, comprising a slotted ring constructed with a flange at one end thereof, the ring itself being adapted to fit upon the box, with a radial spur upon said box fitted into the slot of said ring, and the flange of the latter having studs or fins, that project inward to fit into holding-cavities formed in the face of a recess receiving the device, by which means the device, constructed as just set forth, is firmly fixed within the hub, and, in its turn, is firmly connected with the box, thereby insuring the permanence in position of the box with reference to the hub in closing the same.

Figure 1 is a longitudinal sectional view of a hub embracing my invention. Fig. 2 is a transverse sectional view of the same. Figs. 3 and 4 are detached detail views of parts comprised therein; and Fig. 5 is a detail view, representing a modified construction of the parts represented in Figs. 3 and 4.

A is the hub, having the usual longitudinal bore. B is the tubular or thimble box, and C C are the cushions, of india-rubber, sustaining said box at each end, provision being made for the retention of the box within the hub by any ordinary or suitable means. Upon the box B, at any suitable distance from one end thereof, is provided a radial spur or projection, A', the function of which will be herein presently set forth. D is a ring, which is longitudinally slotted, as shown at *b*, and provided at one end with the circumferential flange *c*. This flange is notched,

as represented at *a'* in Fig. 3, this notch being, as it were, an extension of the slot *b* in the ring D. Provided upon the inner face of the flange *c* are studs *b'*.

In the construction of the hub embracing my said invention the shoulder *f'* at the inner end of one of the recesses containing the cushions C C has formed in it cavities *d*. The ring D is slipped upon the box B until the spur A' is brought into the slot *b* and notch *a'* of the said ring, whereupon, the parts being properly manipulated, the studs *b'* are pressed into the cavities *d*, and the adjacent cushion C being put in place, and the box B being brought longitudinally home to its position, the studs *b'*, holding in the cavities *d*, effectually prevent the turning of the ring D within the hub. In like manner the spur or projection A', holding in the slot *b* and notch *a'*, prevents the turning of the box B within the said ring—in other words, within the hub—it being expressly understood that the ring D, being of the sleeve-like form represented more fully in Figs. 3 and 4, and embracing a greater length of the box B, insures the steadiness of the hold of the ring upon the box B, and thereby insures a more efficient operation of the device than has hitherto been possible with any analogous means of securing a like result.

It is also to be understood that, in place of the studs or projections *b'* on the ring D, radial fins, as represented by the same reference-letter in Fig. 5, may be employed, said fins being bedded in the wood of the hub, in a manner substantially the same as the studs or projections, as hereinbefore explained, and serving the same purpose.

What I claim as my invention is—

The ring D, of sleeve-like form, slotted at *b*, constructed with the flange *c*, having the studs or fins *b'*, notched at *a'*, in combination with the radial spur or projection A' of the box B, and the cavities *d* in the face of a recess formed in the end of the hub, all as herein set forth, for the purpose specified.

GEO. W. HAYES.

Witnesses:

EDWARD HOLLY,
H. WELLS, Jr.