

S. P. EVANS.
DITCHING-MACHINE.

No. 189,440.

Patented April 10, 1877.

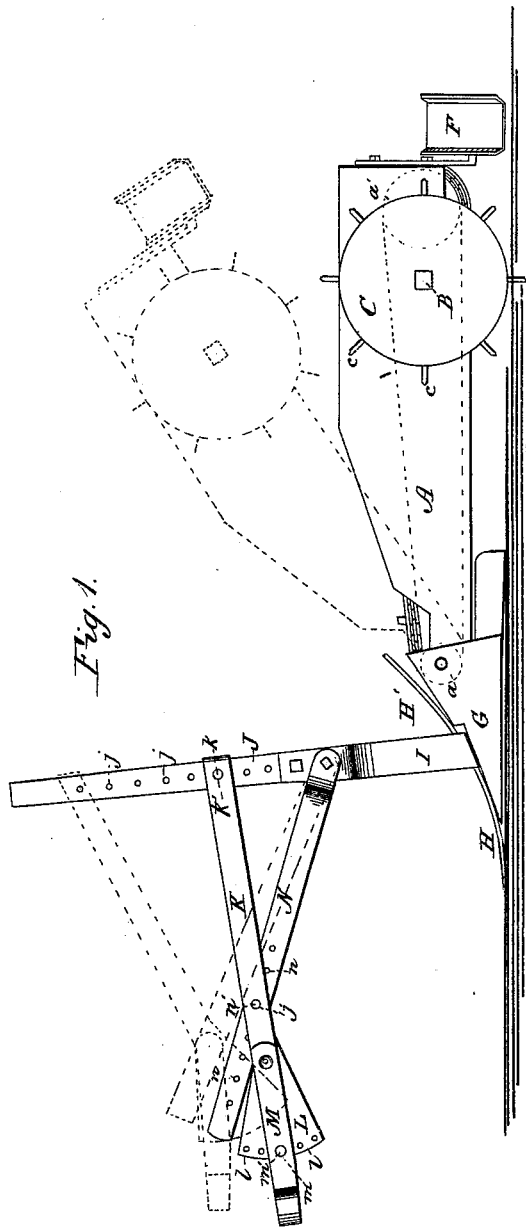

Fig. 1.

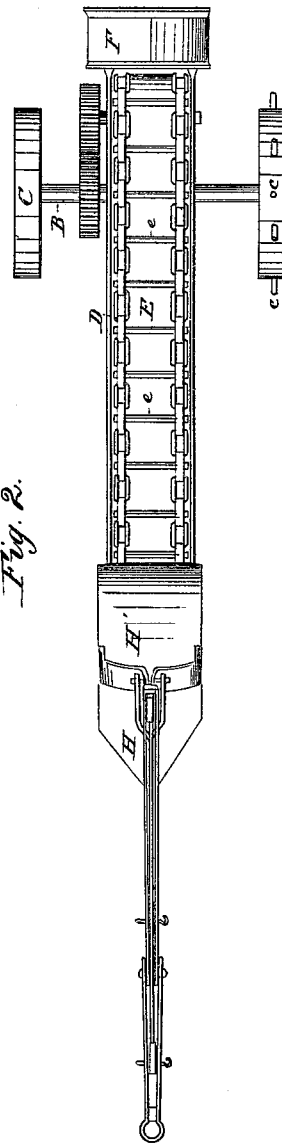

Fig. 2.

WITNESSES:

John C. Kemou.
Chas. A. Pettit

INVENTOR:

S. P. Evans.

BY

Reynolds & Co.

ATTORNEYS.

UNITED STATES PATENT OFFICE.

SILVANUS P. EVANS, OF ASH RIDGE, OHIO.

IMPROVEMENT IN DITCHING-MACHINES.

Specification forming part of Letters Patent No. 189,440, dated April 10, 1877; application filed September 18, 1876.

To all whom it may concern:

Be it known that I, SILVANUS P. EVANS, of Ash Ridge, in the county of Brown and State of Ohio, have invented a new and useful Improvement in Ditching-Machines; and I do hereby declare the following to be a full, clear, and exact description of the same, reference being had to the accompanying drawings, forming part of this specification, in which—

Figure 1 represents a side elevation of the invention, and Fig. 2 a plan of the same.

The invention consists in providing a ditching-machine with an apparatus whereby the shoe which bears the colter may be quickly and readily lowered or raised, as it is desired, to cut the ditch or trench deeper or shallower.

In the accompanying drawings, A represents the trough of a ditching-machine, moving on the axle B near the rear end of said machine and the wheels C, the latter being provided with projections or spikes *c c* around their circumferences to give the machine a firmer hold to the ground when in operation. At the front and rear ends of said trough the rollers *a* and *a'*, respectively, have their bearings in its sides, the latter being provided with the projections *a''* on each edge of its circumference, to engage the links of the chains D, which are secured to each side of the endless band E, said endless band being provided with transverse clips *e e* at regular distances throughout its extent, which clips serve the purpose of bearing backward the earth and delivering it to the chute at the rear when the front end of the trough is inclined downward.

On the axle B is a cog-wheel, which meshes with a similar one on the projecting shaft of the roller *a'*, so that motion is communicated to said roller, and thence to the endless band E as the machine advances, the endless band traveling, between the rollers, over a bed fixed longitudinally in the trough A, and delivering its load at the rear end into a chute, F, which is arranged to distribute the earth on both sides of the ditch.

Pivoted to the front end of the trough is the shoe G, which carries the colter H. Said shoe is provided on each side, below, with directing-bars, which extend backward under the trough in line with the point of the colter, and has secured to its upper part a mold-

board, H', which curves backward and upward from the colter and projects over the front edge of the trough.

Secured to the shoe, on each side of the colter, are upright cutters I I, for forming the sides of the ditch. The upper parts of said cutters bend inward, and then upward, having secured between their tops a standard, J, provided longitudinally with holes *j j*, over which standard slides the rear end of the looped draw-bar K; also provided with a hole, *k*, on each side, by means of which, in conjunction with the holes *j j* and pin *k'*, the rear end of the draw-bar is made vertically adjustable on the standard.

To the front, between the ends of the draw-bar, and forming the front of the loop that it makes, is secured the point of the sector-shaped piece L, provided along its arc with the holes *l l*. The pivoted clevis M swings over the piece L, and has the holes *m m* on each side corresponding in position with the holes *l*, by which, together with the holes *m* and pin *m'*, the clevis is made adjustable upon the arc of the piece L.

Pivoted at its forked lower end to the junction of the upright cutters I and standard J is the connecting bar or brace N, its forward upper end, which travels in the loop or slot of the draw-bar, being provided longitudinally with holes *n*, by means of which, in conjunction with the holes *j'* near the forward end of the draw-bar, and the pin *n'*, said brace may be secured to the draw-bar at different elevations.

When it is necessary to lower the colter the rear end of the draw-bar is secured at a higher point on the standard by the means heretofore described, and the front end is elevated and attached nearer the front upper end of the brace N. Reversing these actions serves to raise the colter. Also, by means of the combination of the sector-shaped piece L and pivoted clevis M, the colter may be depressed or elevated within short distances. At times it may be necessary to unite both of these processes, in order to place the colter in a proper position.

Having thus described my invention, what I claim as new, and desire to secure by Letters Patent, is—

1. In a ditching-machine, the combination, with the trough A, pivoted or hinged shoe G, colter H, and upright side cutters I, of the standard J, draw-bar K, connecting-brace N, and clevis M, all constructed and arranged substantially as shown and described, for the purpose specified.

2. In a ditching-machine, the combination, with the trough A, hinged or pivoted shoe G, colter H, and upright side cutters I, of the

standard J, draw-bar K, connecting-brace N, sector-shaped piece L, and pivoted clevis M, all constructed and arranged substantially as shown and described, for the purpose specified.

The above specification of my invention signed by me this 13th day of September, 1876.

SILVANUS P. EVANS.

Witnesses:

SOLOM C. KEMON.

CHAS. A. PETTIT.