

J. A. HOUSE.
SCROLL-SAW.

No. 189,461.

Patented April 10, 1877

Fig 1.

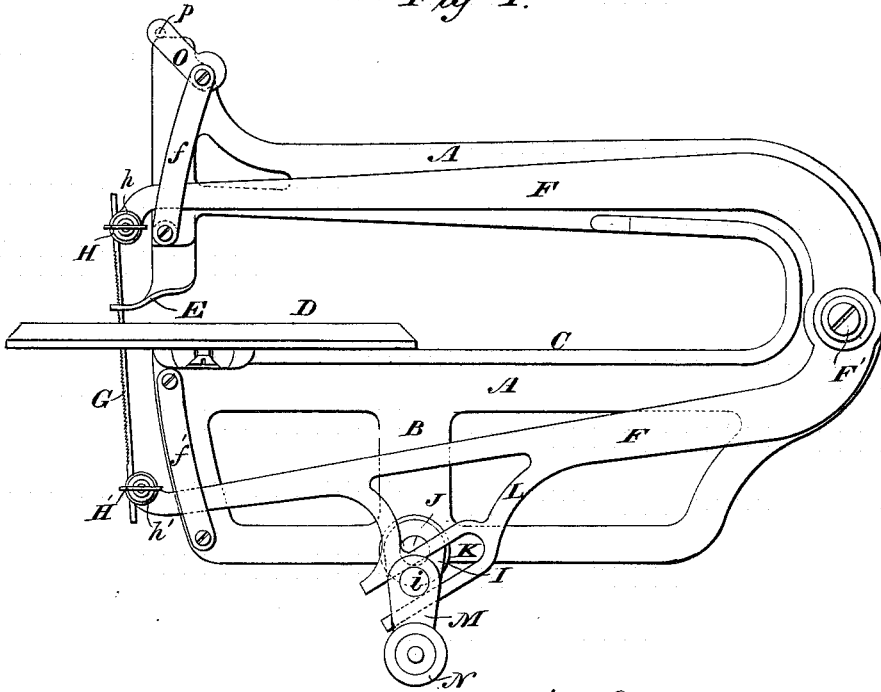
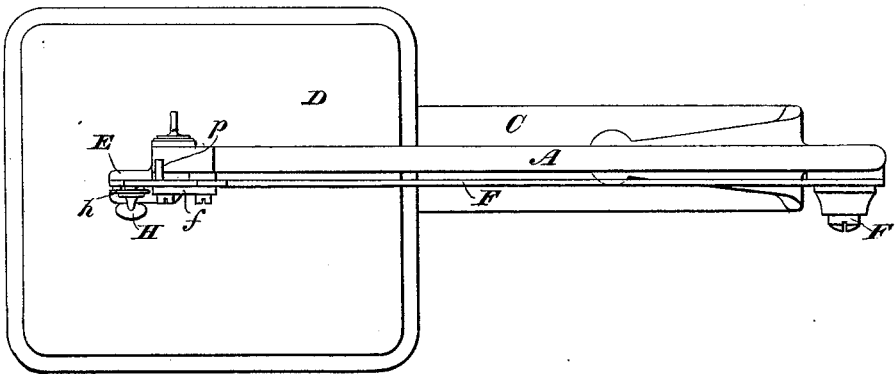

Fig 2



WITNESSES

Wm A Skinkle
J. Peck

INVENTOR

James A. House.

By his Attorneys.

Baldwin, Hopkins & Lytton

J. A. HOUSE.
SCROLL-SAW.

No. 189,461.

Patented April 10, 1877.

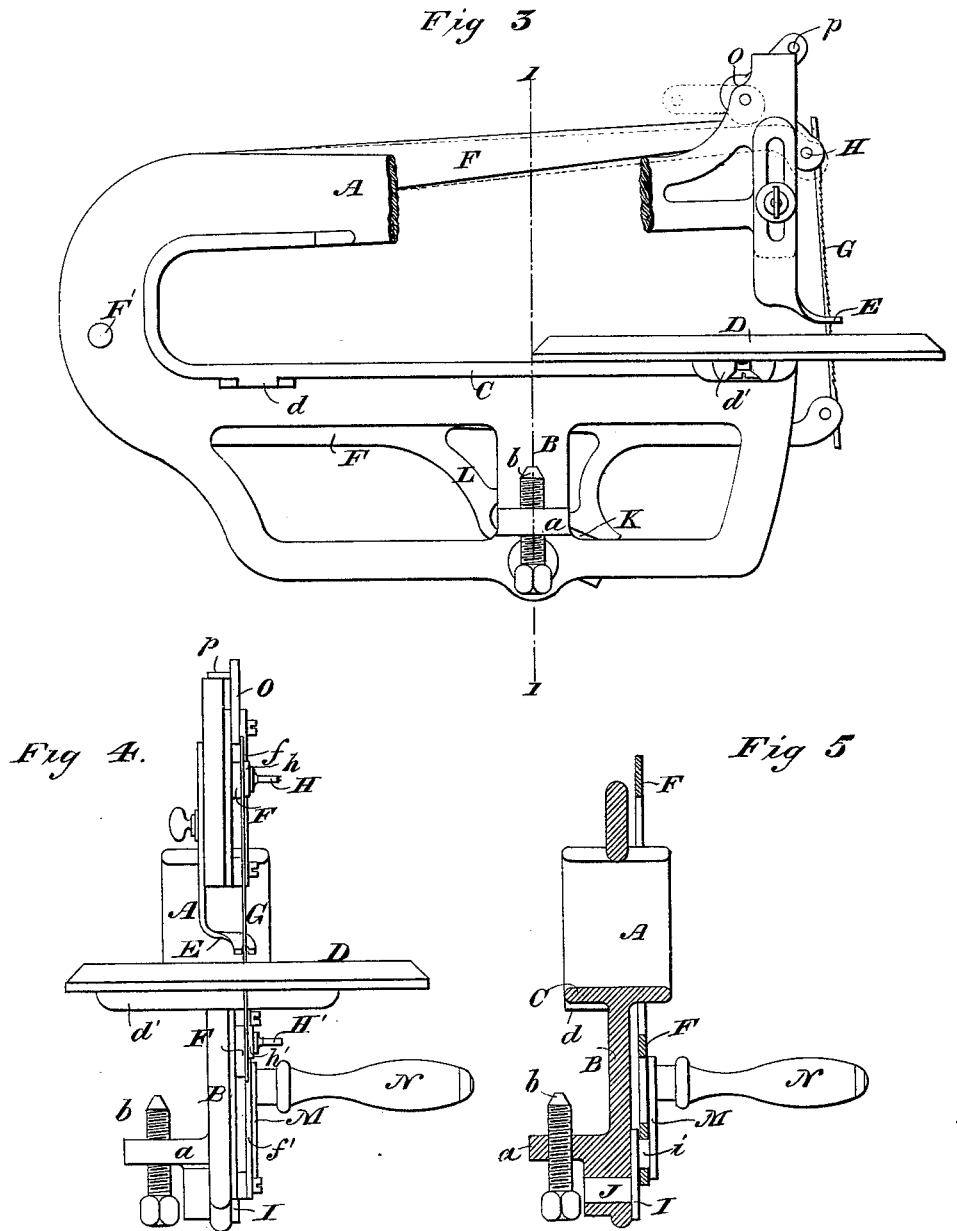

WITNESSES

Wm. A. Skinkle
J. Smith

INVENTOR

James A. House.

By his Attorneys.

Baldwin, Hopkins & Peyton

UNITED STATES PATENT OFFICE.

JAMES A. HOUSE, OF BRIDGEPORT, CONNECTICUT.

IMPROVEMENT IN SCROLL-SAWS.

Specification forming part of Letters Patent No. **189,461**, dated April 10, 1877; application filed March 3, 1877.

To all whom it may concern:

Be it known that I, JAMES ALFORD HOUSE, of Bridgeport, in the county of Fairfield and State of Connecticut, have invented certain new and useful Improvements in Scroll-Saws, of which the following is a specification:

My improvements chiefly relate to a scroll-sawing machine of the class designed to be operated by hand-power; and the objects of my invention are to provide a simple, strong, cheap, light-running, and efficient machine.

The improvements claimed consist in certain novel constructions of devices and combinations of parts hereinafter specifically designated.

In the accompanying drawings, Figure 1 is a side elevation; Fig. 2, a plan or top view; Fig. 3, an elevation, as seen from the side opposite that represented by Fig. 1, with a portion of the frame of the machine broken away to illustrate more clearly the manner of straining the saw; Fig. 4, an end view or front elevation, and Fig. 5 a transverse section on the line 1 1 of Fig. 3.

A metallic bifurcated or C-shaped supporting-frame, A, preferably of cast-iron, is provided with a clamping-screw, *b*, which passes through a lug or short arm, *a*, projecting from the pendent portion or downwardly-projecting bracket B of the cast-metal frame. By means of this screw the saw-supporting frame may readily be secured to and detached from a stand, table, or bench the edge of which is gripped between an overhanging flange, C, projecting laterally from the frame and the set-screw. Instead of having the flange C bear directly upon the table or bench, bearing-surfaces *d d'*, projecting slightly beyond the general surface of the under side of the flange, are preferably provided, as shown in Fig. 3.

The table D, to support the work, is secured upon the upper surface of the lower portion or arm of the frame A, and an adjustable presser-foot or holder, E, is secured to the outer enlarged end of the upper portion of the frame, to bear upon the material being operated upon, for a well-known purpose. The table D, it will be seen, is securely held in place upon the widened end of the lower portion of the frame A.

The saw-frame proper, or saw-arms F, are

formed in one piece, and of the shape shown. They are united to the supporting-frame at their bent end by a screw-pivot, F', or other suitable removable pivot at the bend or back of the frame A. The outer ends of the saw-frame or arms work in guides or controlling ways at the ends of the supporting-frame, which are formed by flat rods or plates *f f'* secured to the frame by screws, and set off from the frame by means of washers a distance sufficient to admit free play up and down to the saw-arms, the one above and the other below the table, while preventing any lateral movement.

The saw-blade G is secured at its ends to the saw-arms by means of adjustable thumb-screws H H' between heads *h h'*, on which, and the saw-arms, the blade is clamped.

The saw-arms are rocked upon their pivot F', and the saw rapidly reciprocated by means of the crank-pin or wrist *i* of a crank-arm, I, upon a short shaft, J, mounted in the bracket or pendent portion B of the frame, which crank-pin works in a slot or way, K, formed in a bracket or downwardly-projecting portion, L, of the lower saw-arm. To the wrist of the crank I is secured a second crank, M, provided with a handle, N, for operating the machine.

The upper saw-arm is slightly springy or yielding, and a cam-lever, O, for straining the saw-blade, is mounted above this arm, and near its end on the frame of the machine, as clearly shown in the drawings. By reference to the full and dotted lines in Fig. 3, it will be seen that when the crank is turned so as to bring it on the upper center, and thus raise the saw-arms to their greatest elevation, and the cam-lever turned down, the saw-arm is sprung from the position shown by full lines to that represented by the dotted lines. When in this latter position the saw-blade is securely clamped in place, and the lever O raised, thus most effectually straining the saw. When in the elevated and inoperative position the pin *p*, near the end of the lever, rests upon a stop formed by the top portion of the end of the frame, and is thus prevented from accidentally swinging down in the way of the saw-arm.

From the foregoing description, the opera-

tion of my improved machine will readily be understood. It will be noticed that the crank-shaft I is mounted loosely in its bearing in the frame, endwise movement being prevented by the lower saw-arm and its slot, and the second crank. The guides *ff'* prevent sidewise movement of the saw-frame, and thus prevent possibility of the crank-shaft working endwise in its bearing to an injurious extent. To remove the crank-shaft, all that is necessary to be done is to take out the pivot *F'*, detach the saw-blade, and remove the guide-plates *ff'*, or, preferably, take off the clamp-screws *H H'*, when the saw arms or frame may be withdrawn rearward, so as to clear it from the crank. By pivoting the saw-frame to the supporting-frame about in the plane of the top of the table, or somewhat beneath, rather than at a point midway between the upper and lower portions of both the saw-frame and supporting-frame, it will be observed that on the down or cutting stroke of the saw it advances slightly, while on the upper inoperative stroke it retracts slightly. In this way the work is facilitated, as the operator, by slightly pressing forward the material, is enabled to feed it properly to the saw, there being no impediment to a limited movement of the material upon the up-stroke.

The saw-arms are made considerably lighter at and near their outer ends than at and near the pivot *F'*, thus preventing the binding of the arm upon the pivot by preventing the springing of the arms at or near it when straining the saw-blade.

Obviously my improvement may be slightly modified without departing from the spirit of my invention. For instance, a single instead of a double crank might be employed. The

bracket of the lower saw-arm having the slot for the traverse of the crank might be extended downward a distance greater than shown in the drawing, and sufficiently far to admit of the extension of the crank-shaft (which would be correspondingly lowered) beneath the clamping-screw, so as to receive a band-wheel, thus providing for the driving of the saw by mechanical power or by foot-power; but I prefer the construction shown in the drawings, and hereinbefore described, as the saw thus made is exceedingly strong and simple in all its parts, and runs very lightly.

I claim as my invention—

1. The combination of the bifurcated supporting-frame, having the pendent portion or bracket projecting from its lower arms, and adapted to be clamped in position, the saw-arms pivoted to the frame, the guideways in which the outer ends of the saw-arms work, the slotted bracket on the lower saw-arm, and the crank mounted in the pendent portion of the saw-supporting frame, and working in the slot in the saw-arm bracket, these members being constructed and operating substantially as hereinbefore set forth.

2. The combination, substantially as hereinbefore set forth, of the supporting-frame, the pivoted saw-arms provided with clamps to secure the saw-blade in place, and the cam-lever mounted upon the supporting-frame, and acting directly upon the yielding saw-arms to strain the saw-blade, as set forth.

In testimony whereof I have hereunto subscribed my name.

JAMES ALFORD HOUSE.

Witnesses:

A. R. LACY,
A. W. HURD.