

F. M. MAHAN.
COMBINED FLOUR AND PASTRY CUPBOARD AND KNEADING
BOARD.

No. 189,479.

Patented April 10, 1877.

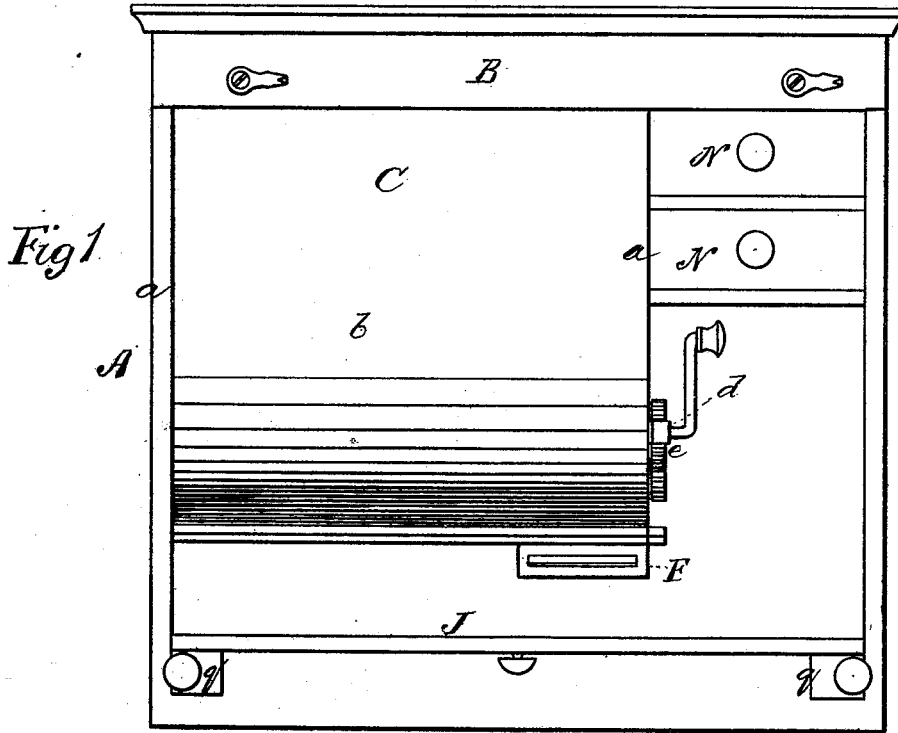

Fig. 1.

Fig. 2.

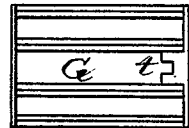

Fig. 3.

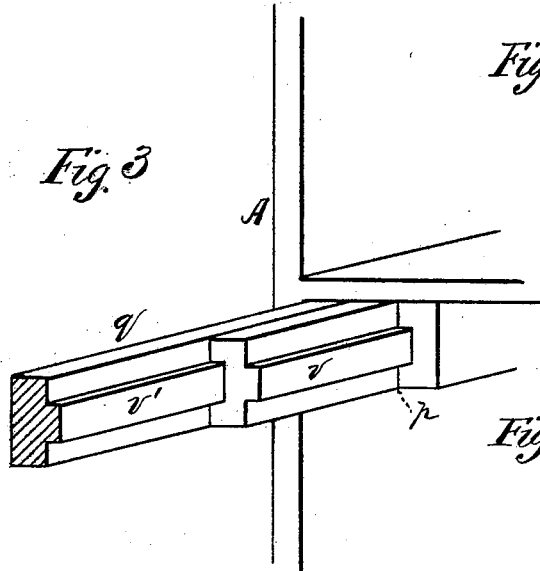
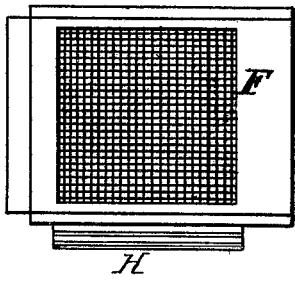

Fig. 4.



WITNESSES

Mr. S. Utley
C. J. Massie

INVENTOR

Frank M. Mahan,
by C. W. Anderson,
ATTORNEY.

F. M. MAHAN.
COMBINED FLOUR AND PASTRY CUPBOARD AND KNEADING
BOARD.

No. 189,479.

Patented April 10, 1877.

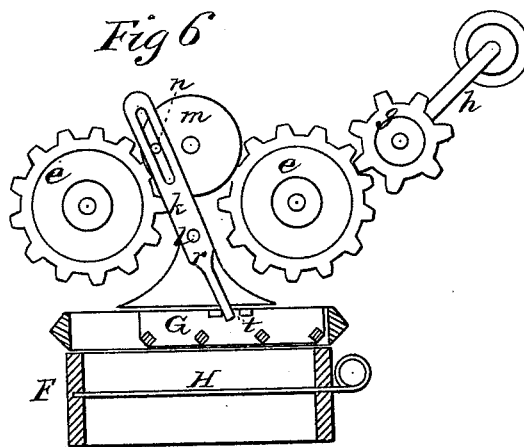
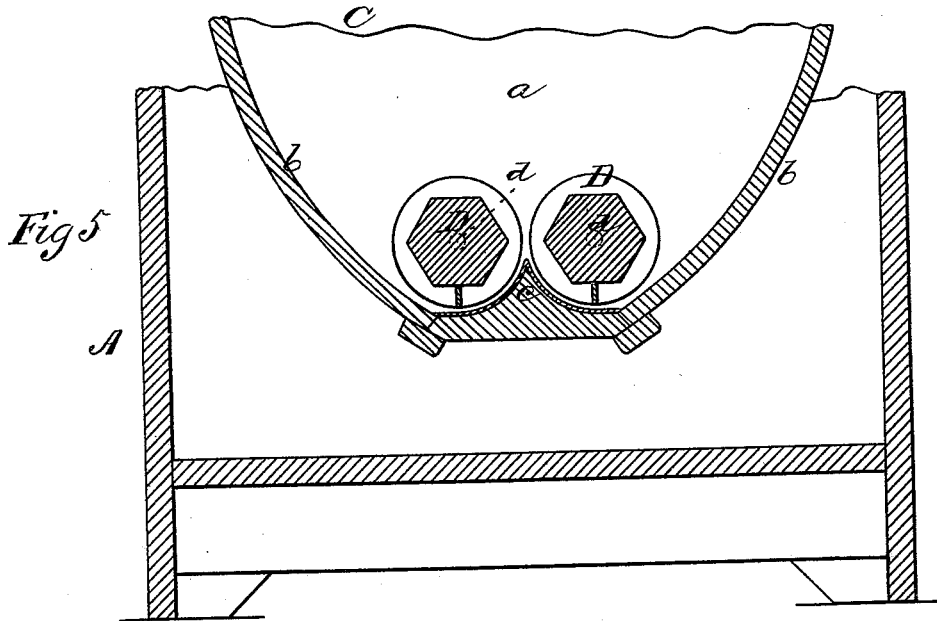

WITNESSES

W. S. Utley,
A. J. Chasi

INVENTOR

Frank M. Mahan,
by E. W. Anderson,

ATTORNEY

F. M. MAHAN.
COMBINED FLOUR AND PASTRY CUPBOARD AND KNEADING
BOARD.

No. 189,479.

Patented April 10, 1877.

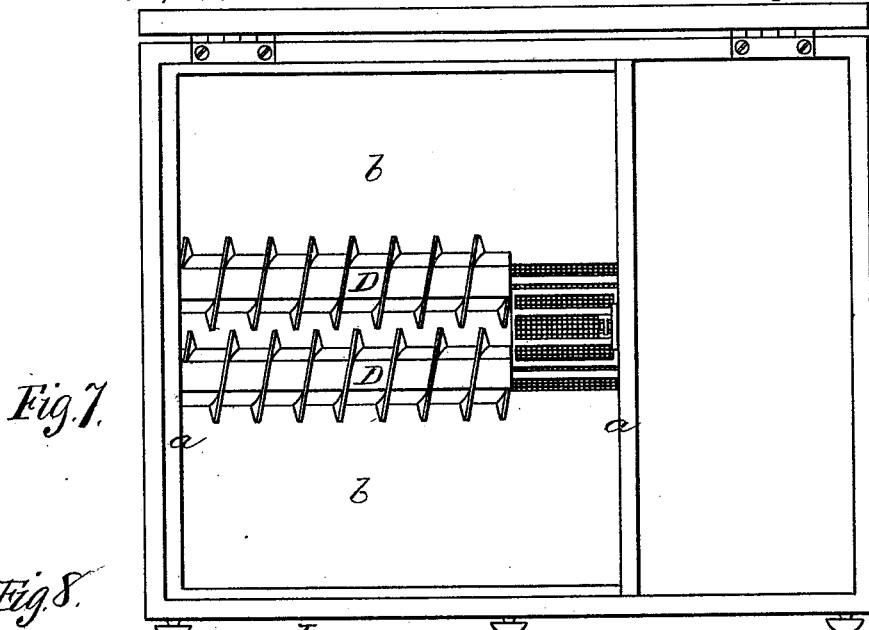
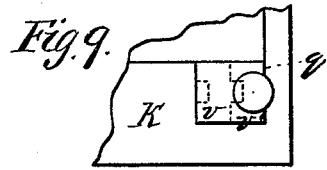
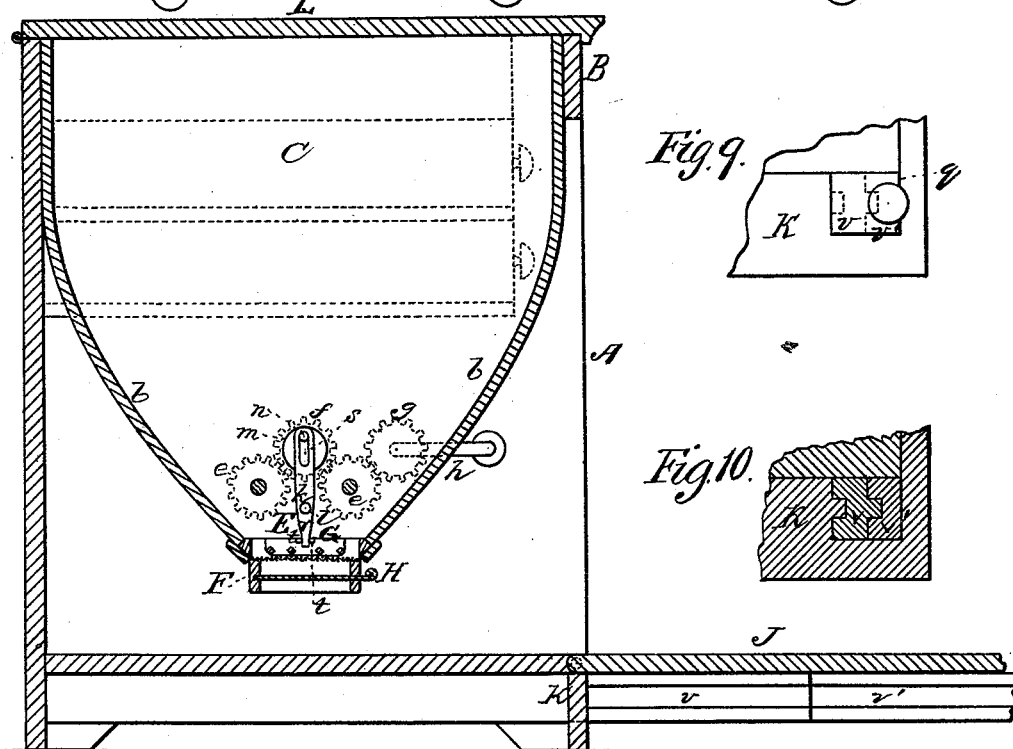

Fig. 7.

Fig. 8.



WITNESSES

No. S. Utley.
F. Jellasi

INVENTOR

Frank M. Mahan
by *E. W. Anderson*
ATTORNEY

UNITED STATES PATENT OFFICE.

FRANK M. MAHAN, OF ST. JOSEPH, MISSOURI.

IMPROVEMENT IN COMBINED FLOUR AND PASTRY CUPBOARD AND KNEADING-BOARD.

Specification forming part of Letters Patent No. 189,479, dated April 10, 1877; application filed February 10, 1877.

To all whom it may concern:

Be it known that I, FRANK M. MAHAN, of St. Joseph, in the county of Buchanan and State of Missouri, have invented a new and valuable Improvement in Combined Flour and Pastry Cupboard and Kneading-Board; and I do hereby declare that the following is a full, clear, and exact description of the construction and operation of the same, reference being had to the annexed drawings, making a part of this specification, and to the letters and figures of reference marked thereon.

Figure 1 of the drawings is a representation of a front view of my improved flour and pastry safe, bin, and board. Figs. 2, 3, 4, 6, 9, and 10 are detail views. Figs. 5 and 8 are vertical cross-sections. Fig. 7 is a top view of the invention with the lid thrown open.

This invention has relation to flour-bins; and it consists in the construction and novel arrangement of the shelving hopper walls and the conveyers at the bottom thereof, the sieve and the agitator, the divider between the conveyers, the mechanism for operating the conveyers and the agitator, and the extension-slides, in combination with the kneading-board, all as hereinafter shown and described.

In the accompanying drawings, the letter A designates the case of the bin, which may be of the usual rectangular form. In the construction usually adopted the front is open, and a cross-bar, B, is extended across the top of said front, to support the bin C. This consists of two plain vertical end walls, *a*, and two shelving side walls, *b*, which slope toward each other downward to a bottom composed of one or more parallel channels or flutings, which are formed by said walls, and dividing-ridges *c*. Each channel constitutes a bed or semi-chamber for a screw-conveyer, D, which is designed to fit its bed neatly. The number of such channels and conveyers will be optional, and determined mainly by the shape and capacity of the hopper or bin. These channels and conveyers extend from one end of the bin to a discharging-space which is left between said conveyers and the other end of the bin. The shafts *d* of the conveyers extend across said space and through the end wall *a*, and are provided with spur-wheels *e* on their ends.

The discharge E consists of a square or oblong opening through the bottom at one end, as stated. It is provided with grooves or slideways for the removable sieve F, which usually consists of a rectangular frame, upon which wire-cloth is strained. Just above said sieve, and bearing upon its frame, is arranged a vibratory grate or agitator, G, the object of which is to agitate the flour upon the sieve, and cause it to pass freely through the meshes thereof.

Motion is given to the conveyers and agitator in the following manner: Between each pair of spur-wheels *e* of the conveyers is arranged a pinion, *f*, attached to the end of the bin, and designed to engage with said spur-wheels in such a manner as to communicate motion in the same direction from one to the other. The driving-pinion *g* is provided with a crank, *h*.

Instead of spur-gearing it may be desirable to employ beveled pinions on a shaft journaled across the end of the bin, said pinions engaging with beveled pinions on the ends of the conveyer-shafts.

The vibratory motion of the agitator is produced by means of a slotted lever, *k*, having its fulcrum at *l*, and engaging by its slot *s* with a stud, *n*, on a disk, *m*, connected to the pinion *f* or the shaft thereof, and by its foot *r*, with a bearing, *t*, of the agitator. When the gearing is in motion the lever is rapidly vibrated, and the agitator moved in a rapid reciprocating manner over the sieve. Below the sieve is arranged, in suitable ways, a sliding bottom or cut-off, H, which is used to close the discharge-opening, and check the fall of flour or meal when desired.

Sometimes it may be preferred to use a thin hood or fender above the sieve and agitator, so adjusted as to prevent the access of flour to the sieve, except as conducted thereto by the conveyers. If this construction is adopted the conveyers may extend entirely across the bin, the discharge being exterior thereto in the form of a spout under the gearing.

Sometimes the bin may be constructed with an ordinary cupboard-support, but it is more portable in the form illustrated, and, in connection with the kneading-board, affords a cheap pastry convenience. This kneading-

board is hinged to the base-bar K, which extends across the bottom in front, and is designed to swing upward to close the open front of the box. Under it, and seated in grooved passages *p* in the base of the chest, are extension-supports or arms *q*, which consist of tongued and grooved bars *v v'*, which engage with each other, and with said passages. These supports are drawn out to afford bearings for the kneading-board, which is swung downward upon its hinges. Its working-face is kept clear, being turned inward when it is closed up, to form the front of the box. When not needed for use, the supports are pushed entirely into their passages in the base, and show only their ends, which may be finished with metallic plates.

The top L of the box or chest is hinged to open upward when the bin needs replenishing. Within the box or chest, in the space between its end wall and the end of the bin, are arranged, in suitable slides, small drawers N, for spices or other articles.

Having described this invention, what I claim as new, and desire to secure by Letters Patent, is—

1. The combination, with a flour or meal bin having a discharge-orifice at one end, of the conveyers D D, a mechanism for rotating them in the same direction, the sifter F, and reciprocating agitating-grate G, substantially as specified.

2. In combination with the bin C, having rotary agitators at its lower end, pinions *e*, upon adjacent ends of the agitator-shafts, pinion *f*, meshing with pinions *e*, a master-gear, *g*, and its crank *h*, of the disk *m*, stud *n*, slotted lever *k*, sliding agitator G, and a sifter arranged under the discharge-orifice of the bin, substantially as specified.

3. The rests *q*, consisting of the sections *v v'*, tongued and grooved into each other, and the former extensible relative to the other, in combination with the hinged front J of a bin-case, substantially as specified.

In testimony that I claim the above I have hereunto subscribed my name in the presence of two witnesses.

FRANK M. MAHAN.

Witnesses:

W. J. DONOVAN,

FRANK DUMKE.