

J. MORRISON.

CONSTRUCTION OF REVERBERATORY FURNACES.

No. 189,486.

Patented April 10, 1877.

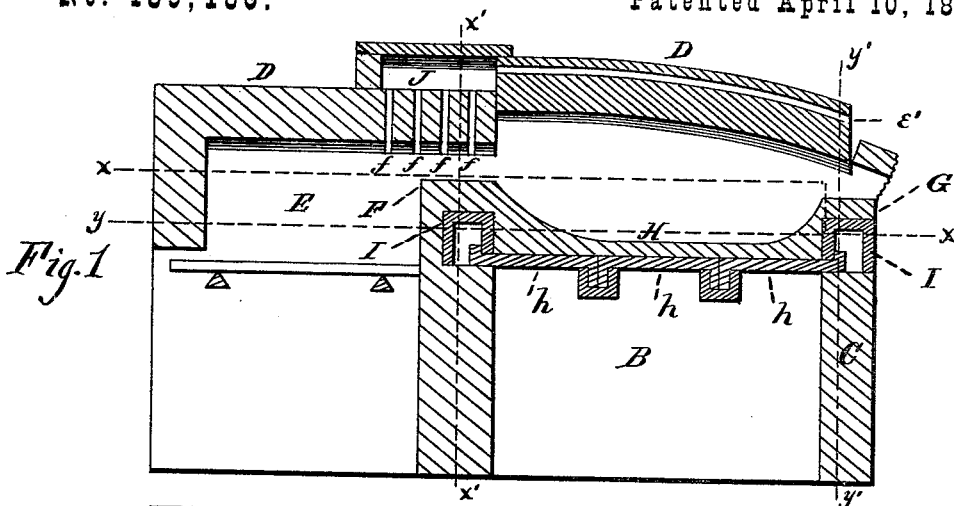

Fig. 1.

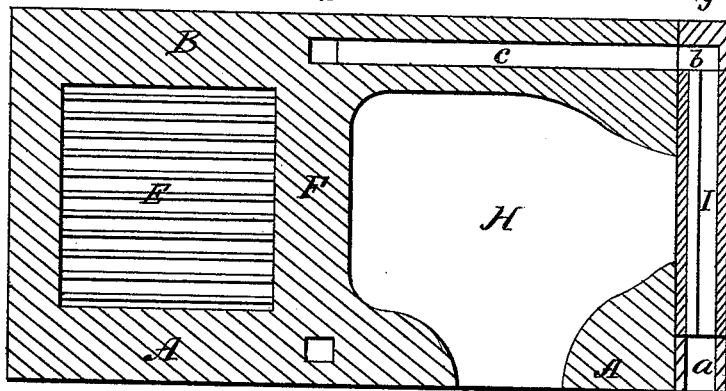

Fig. 2.

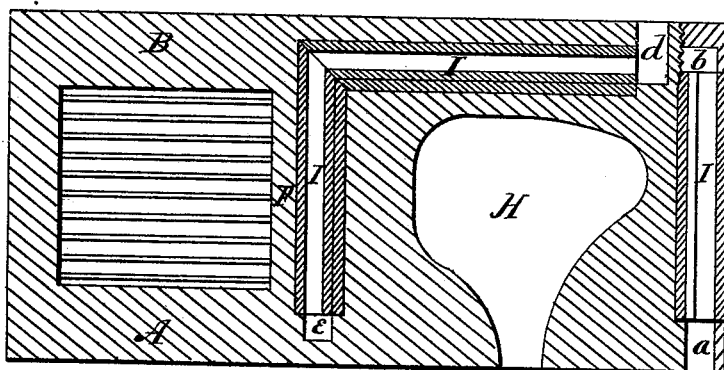

Fig. 3.

Witnesses

F. A. Pollock.  
G. Smith

By

John Morrison, Inventor

Conroy & Co. Attorneys

Attorneys

J. MORRISON.

CONSTRUCTION OF REVERBERATORY FURNACES.  
No. 189,486. Patented April 10, 1877.

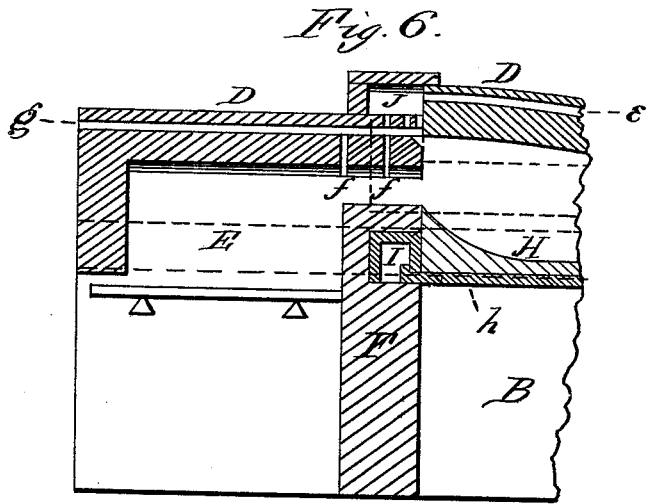
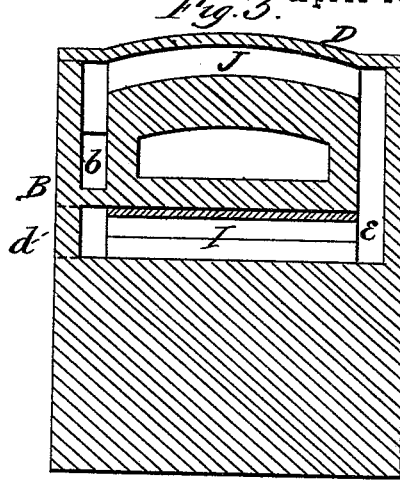
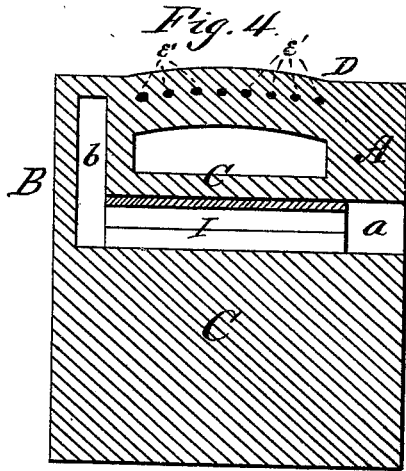

Witnesses

*F. A. Colbeck.*  
*G. Smith*

*By*

*John Morrison* Inventor

*Comally & Wright*

Attorneys

# UNITED STATES PATENT OFFICE.

JOHN MORRISON, OF PITTSBURG, PENNSYLVANIA.

## IMPROVEMENT IN THE CONSTRUCTION OF REVERBERATORY FURNACES.

Specification forming part of Letters Patent No. **189,486**, dated April 10, 1877; application filed December 9, 1876.

*To all whom it may concern:*

Be it known that I, JOHN MORRISON, of Pittsburg, in the county of Allegheny and State of Pennsylvania, have invented certain new and useful Improvements in the Construction of Reverberatory Furnaces; and I do hereby declare the following to be a full, clear, and exact description of the invention, such as will enable others skilled in the art to which it pertains to make and use it, reference being had to the accompanying drawings, which form part of this specification, in which—

Figure 1 is a longitudinal vertical mid-section. Fig. 2 is a horizontal section on line  $xy$ . Fig. 3 is the same on line  $xy$ . Fig. 4 is a transverse vertical section on line  $y'y'$ . Fig. 5 is a similar view on line  $x'x'$ . Fig. 6 is a view similar to Fig. 1, but with an additional feature. Fig. 7 is a plan section of chamber J.

This invention relates to improvements in furnaces of that class in which the combustion of the fuel is aided by the introduction of heated air, having reference particularly to furnaces for puddling, heating, boiling, and other forms of reverberatory furnaces; and it consists in the construction of the various parts and their combination, substantially as hereinafter fully described and claimed.

The accompanying drawings are illustrative of my invention as applied to an ordinary puddling-furnace, in which A is the front wall, B the back wall, C the flue-end rear wall, D the roof, E the fire-chamber, F the fire-bridge, G the flue-bridge, H the hearth,  $h$  the bottom plates, and I the usual air-chills surrounding the puddling-chamber.

Applying my invention, I construct the chill I either as usual or in the form of a closed box open at the ends, and I arrange it in two separate sections, one lying in the flue-bridge G, extending out to an opening,  $a$ , in the front wall of the furnace, and to the rear wall, where it ends in an uptake,  $b$ , rising to a horizontal flue,  $c$ , passing along in the rear wall toward the fire till it reaches a point in line with the fire-bridge F, where it rises vertically to the roof, delivering into an air-chamber, J, at its side, constructed on the roof of the furnace. The other section of the chill communicates

with an opening,  $d$ , made, as seen, in the rear wall at the level of the chill, whence the air passes on through the chill toward the fire-bridge F, reaching which it continues in that section of the chill which traverses this bridge till it reaches the front wall, at which point it rises vertically, by an uptake,  $e$ , into chamber J in the roof. By this means the functions of the chills are undisturbed, the cold air entering as usual; but a new function is added, and I hold that their efficiency is increased, because there necessarily is a stronger draft and greater supply of cold air, while at the same time a simple and ready air-heater is thus made of the chills by causing them to deliver their air into the chamber J and thence to the furnace.

I next construct that part of the roof above the puddling-chamber, which is the hottest part of the furnace, with a number of longitudinal flues,  $e'$ , taking into the roof at the end next the chimney, and passing on into chamber J.

I next construct the arch above the bridge F with one or more transverse slits or openings,  $f$ , delivering the heated air from chamber J in thin sheets upon the products of combustion, and by making two or more openings I secure a cumulative effect, because whatever gases fail of ignition at the first meet more air at the second, and so on, till it is almost impossible to get gases or smoke past all of them. The air at this point serves as a chill upon the roof.

In Fig. 6, I introduce another feature in the arrangement, which introduces air into the fire-chamber roof by means of a number of flues,  $g$ , which, like the other flues, deliver into chamber J or directly into slits  $f$ . As a modification I would suggest a flue entering the rear wall, passing alongside the fire-chamber and delivering into flue  $c$  at or near the neck end of the furnace, as shown by dotted lines in Fig. 6. By means of dampers suitably located, full control of the draft and air may be secured, just as with the ordinary furnace. Thus, all the air passing through the chills, while it cools them, absorbs their heat and is utilized in completing combustion—likewise with the roof, my object being to keep all the parts as cool as may be, and using their heat in heating the air necessary to complete combustion.

Having described my invention, what I claim as new, and desire to secure, is—

The improved metallurgic furnace hereinbefore described, having the two air-heating flues taking respectively into the front and rear walls, each passing half-way around the hearth through the boshes, and then rising to the crown, where they communicate with an air-gathering chamber extending transversely across the crown, and from which the air-current passes into the furnace through a series

of two or more cumulative delivering-slits constructed in the crown, the several parts being combined substantially as and for the purpose specified.

In testimony that I claim the foregoing I have hereunto set my hand this 2d day of December, 1876.

JOHN MORRISON.

Witnesses:

JOHN FERGUSON,

T. J. McTIGHE.