

C. E. OWEN.
METALLIC HUB.

No. 189,489.

Patented April 10, 1877.

Fig. 1.

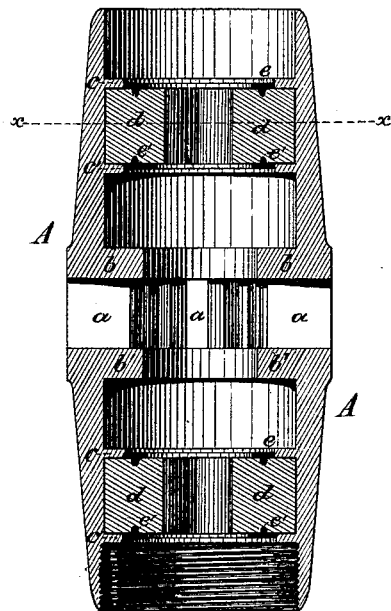
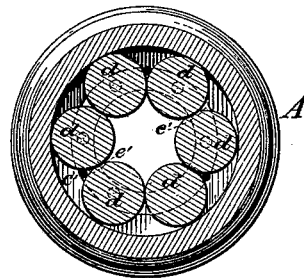

Fig. 2.



WITNESSES

L. M. Seely
B. A. Dyer

INVENTOR

Charles E. Owen
by Geo W Dyer & Co
attys

UNITED STATES PATENT OFFICE

CHARLES E. OWEN, OF FENTON, MICHIGAN.

IMPROVEMENT IN METALLIC HUBS.

Specification forming part of Letters Patent No. 189,489, dated April 10, 1877; application filed October 31, 1876.

To all whom it may concern:

Be it known that I, CHARLES E. OWEN, of Fenton, in the county of Genesee and State of Michigan, have invented an Improvement in Metallic Hubs, of which the following is a specification:

The object of my invention is the production of a cheap and durable metallic hub, which will rotate upon the axle-arm with the minimum amount of friction; and it consists in the combination, with the metallic shell having the spoke-sockets, of two sets of internal flange-rings, one near each end of the hub, and two sets of friction-rollers, to serve as bearings for the axle-arm; and, further, in the combination, construction, and arrangement of the parts composing my improved hub.

To enable others skilled in the art to manufacture my hub, I proceed to describe the same, having reference to the drawings, in which—

Figure 1 is a longitudinal section, and Fig. 2 a cross-section on the line *x x*.

Like letters denote corresponding parts in each figure.

A represents the shell of the hub, cast solid, of any desired external form, and having the spoke-sockets *a* cored therein to receive the tenons of the spokes. The center part of the hub, which receives the strain from the spokes, is made thicker than the ends, as shown, and is cast with two internal flanges, *b b'*, which form the side of the spoke-sockets, and strengthen the hub at these points. Near each end of the hub are cast two internal flange-rings, *c c'*, which receive between them a set of anti-friction rollers, *d*. The rollers *d* fit closely between these flange-rings, and are

of such size that only a small portion, say one-third, is inclosed by such flange-rings. Outside of the flange-rings the rollers are journaled in cage-rings *e e'*, allowing the rollers to turn separately in the cage-rings, and to move freely between the flange-rings.

The axle-arm bears only upon the anti-friction rollers, and the hub is secured to such axle-arm in any convenient manner.

It will be seen, then, that by the construction of my device a metallic hub is obtained which is very simple and cheap in construction, light and durable in use, and at the same time is adapted to rotate with the minimum amount of friction.

Having thus fully described my invention and explained some of its advantages, what I claim as new therein, and desire to secure by Letters Patent, is—

1. In a cast-metal hub, the combination, with the shell A, having the spoke-sockets *a*, of the two sets of internal flange-rings *c c'* and the two sets of friction-rollers *d*, constructed and arranged substantially as described and shown.

2. The cast-metal hub described, consisting of the shell A, the sockets *a*, the strengthening-flanges *b b'*, the internal flange-rings *c c'*, the rollers *d*, and cage-rings *e e'*, all constructed and arranged substantially as described and shown.

In witness whereof I have subscribed this specification.

CHARLES E. OWEN.

In presence of—

H. S. SPRAGUE,
WM. P. SPALDING.