

J. R. TOBIN.

MACHINE FOR CUTTING AND PUNCHING COTTON-BALE TIES.

No. 189,524.

Patented April 10, 1877.

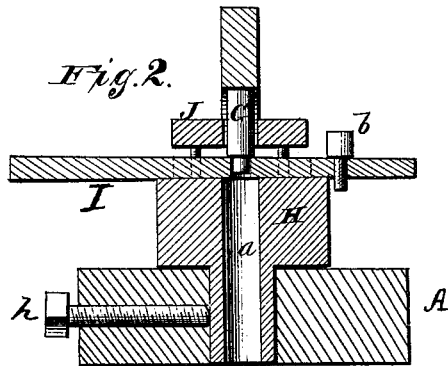
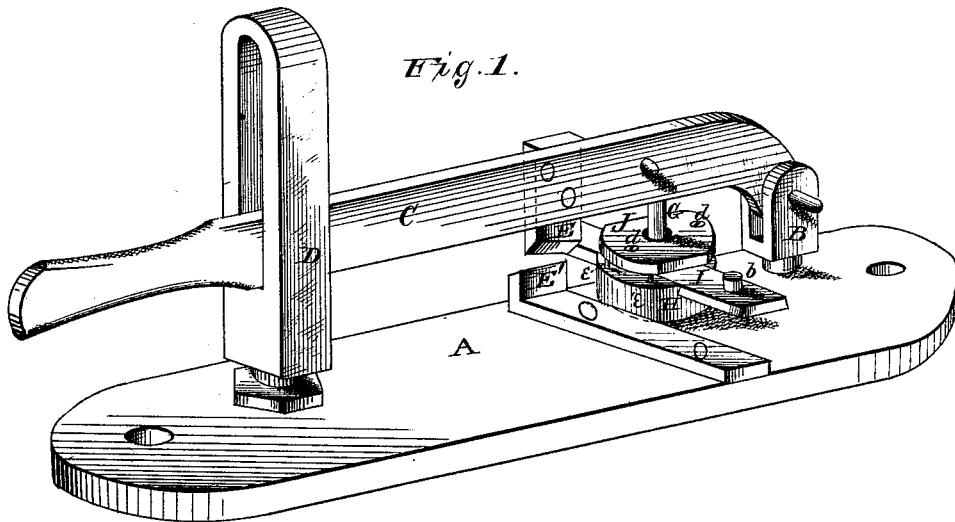

WITNESSES  
*Frank L. Overland*  
*W. J. Jones*

INVENTOR  
*Jno R. Tobin.*  
per  
*J. H. Alexander*  
ATTORNEY

# UNITED STATES PATENT OFFICE.

JOHN R. TOBIN, OF CHARLESTON, SOUTH CAROLINA.

## IMPROVEMENT IN MACHINES FOR CUTTING AND PUNCHING COTTON-BALE TIES.

Specification forming part of Letters Patent No. **189,524**, dated April 10, 1877; application filed November 8, 1876.

*To all whom it may concern:*

Be it known that I, JOHN R. TOBIN, of Charleston, in the county of Charleston and State of South Carolina, have invented certain new and useful Improvements in Combined Cotton-Bale-Tie Cutter and Puncher; and I do hereby declare that the following is a full, clear, and exact description thereof, reference being had to the accompanying drawings, and to the letters of reference marked thereon, which form part of this specification.

The nature of my invention consists in the construction and arrangement of a machine for clipping and punching cotton-ties, as will be hereinafter more fully set forth.

In order to enable others skilled in the art to which my invention appertains to make and use the same, I will now proceed to describe its construction and operation, referring to the annexed drawing, in which—

Figure 1 is a perspective view of my machine. Fig. 2 is a section of a part thereof.

A represents the bed-plate of my machine, on top of which, near one end, is a small fork, B, and in the same is pivoted a curved lever, C, as shown. This lever passes through a vertically-slotted guide, D, fastened near the other end of the bed-plate.

To the lever C, at a suitable point, is secured the cutting-blade E, which works against the stationary L-shaped blade E', fastened on the bed-plate. These cutting-blades E E' are fastened to the lever C and bed-plate A, respectively, by means of screws or bolts, so that they can easily be removed and put back when required for sharpening or other purposes.

To the lever C is pivoted a punch, G, with which the cotton-tie is punched. Under this punch, on the bed-plate, is an anvil or seat, H, provided with a shank, which passes down through the bed-plate A, and is held firmly by means of a set-screw, h, by which it is also

made adjustable; and through this shank and through the anvil is a central aperture, a, made of gradually-increasing diameter from top to bottom.

The top of the anvil H is provided with a dovetailed tapering groove, in which the die I is inserted and held by means of a pin, b, passed through the smaller end thereof, the die being simply in the form of a plate, tapering, and having dovetailed edges, and provided with a hole corresponding with the upper end of the hole a in the anvil.

Above the anvil is a cap, J, fastened by screws d, and supported upon pins e, a suitable distance above the die, so that the cotton-tie can pass in between the die and said cap. In the center of the cap is an aperture, through which the punch G works.

By means of the cutters E E' the operator can cut off or clip one tie, while at the same time, by means of the punch, another tie has the hole punched through it. The piece punched out falls down through the central aperture a in the anvil.

Having thus fully described my invention, what I claim as new, and desire to secure by Letters Patent, is—

The combination, in a machine for cutting and punching cotton-bale ties, of the bed-plate A, provided with cutter E', adjustable anvil H, tapering die I, and perforated top cap J, and the lever C, pivoted to the fork B, and provided with the punch G and cutter E, all constructed and operating substantially as and for the purposes herein set forth.

In testimony that I claim the foregoing as my own I affix my signature in presence of two witnesses.

JOHN ROBT. TOBIN.

Witnesses:

M. I. TOBIN,  
STEPHEN MOLONY.