

J. WADE.
PRINTING PRESS.

No. 189,532.

Patented April 10, 1877.

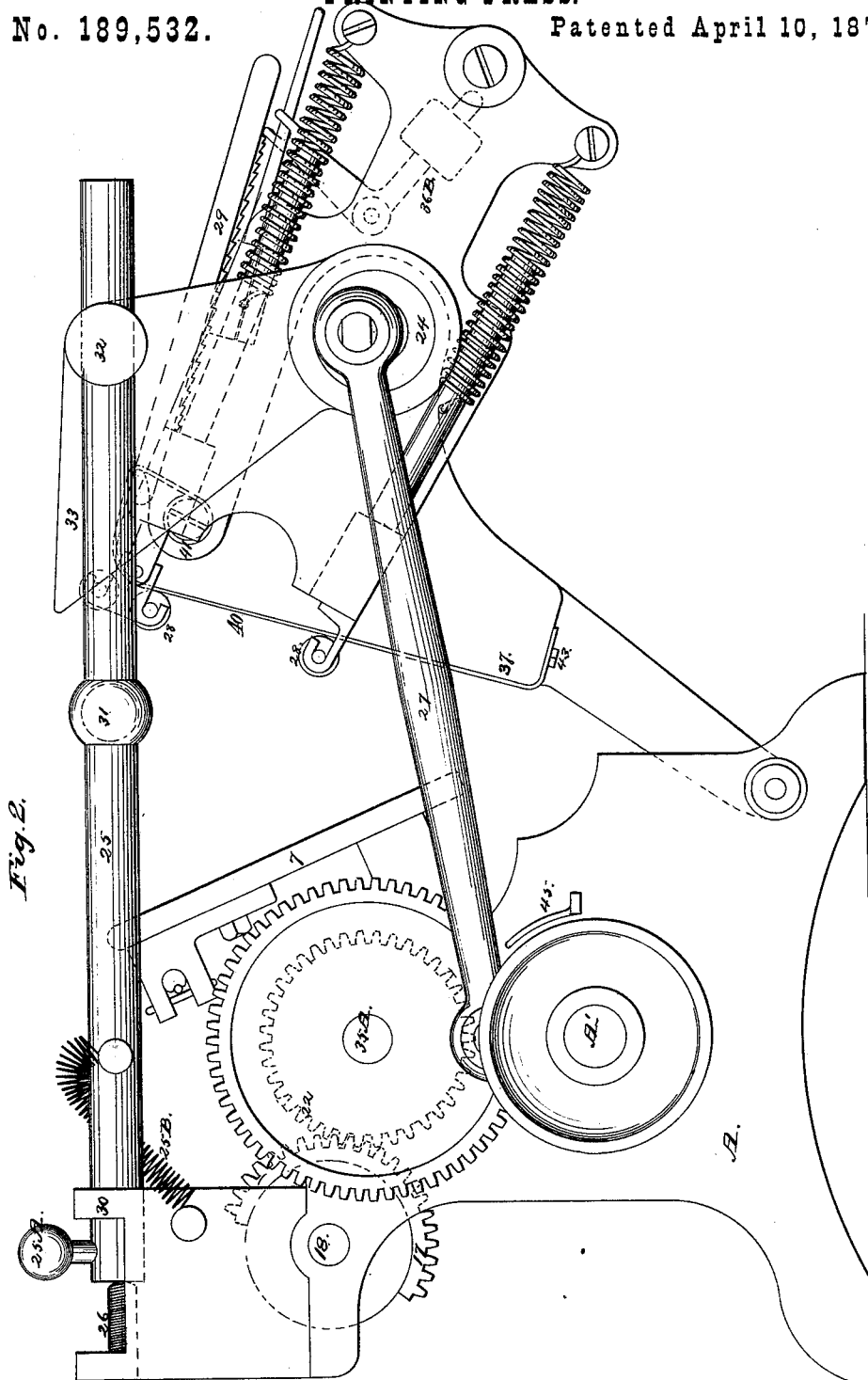

Fig. 2.

Attest
Walter Brierley
Attestor

Inventor:
Josiah Wade

J. WADE.
PRINTING PRESS.

No. 189,532.

Patented April 10, 1877.

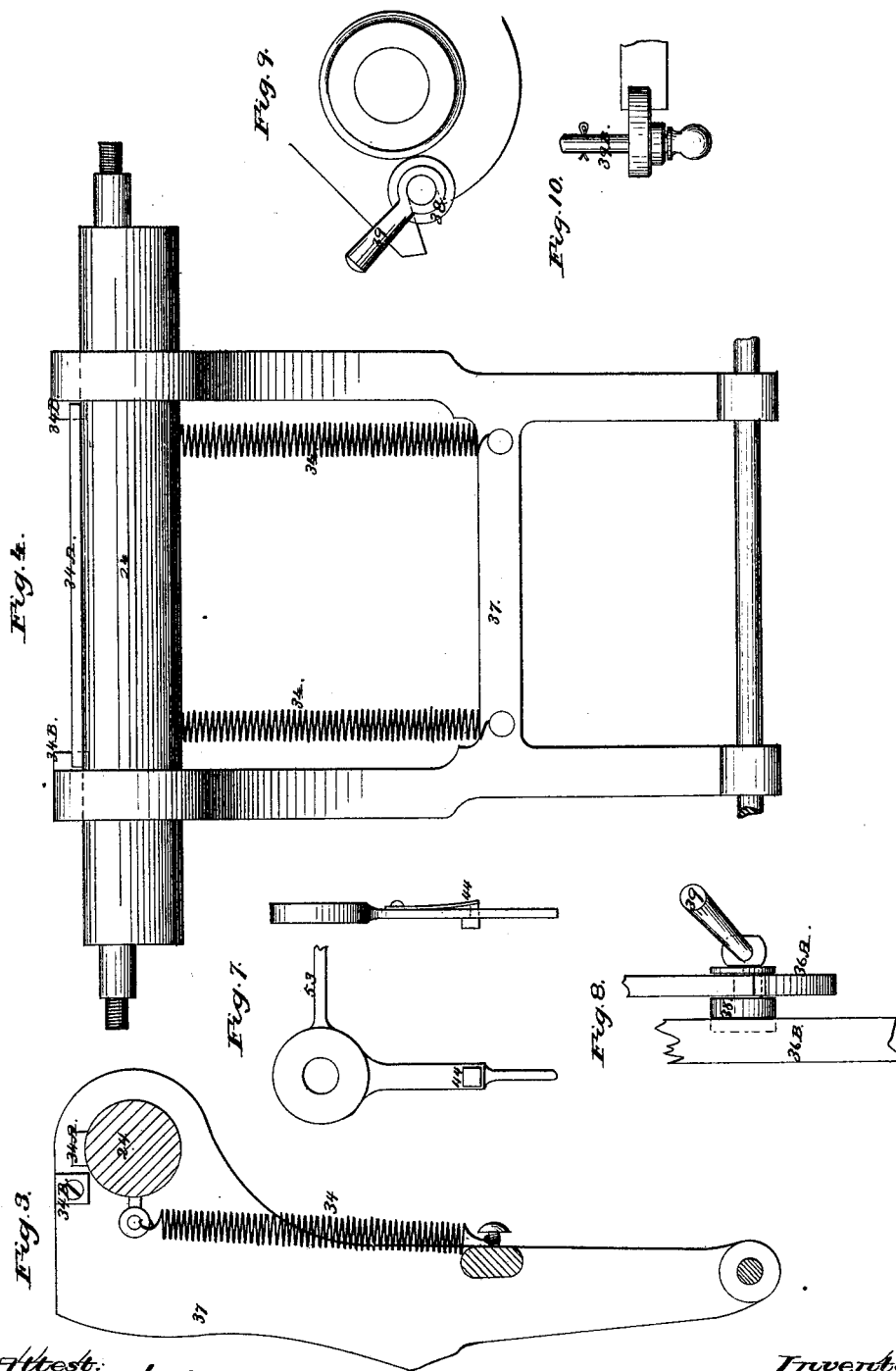

Attest:
Walter Brierley
Arthur Crosby

Inventor:
Josiah Wade

J. WADE.
PRINTING PRESS.

No. 189,532.

Patented April 10, 1877.

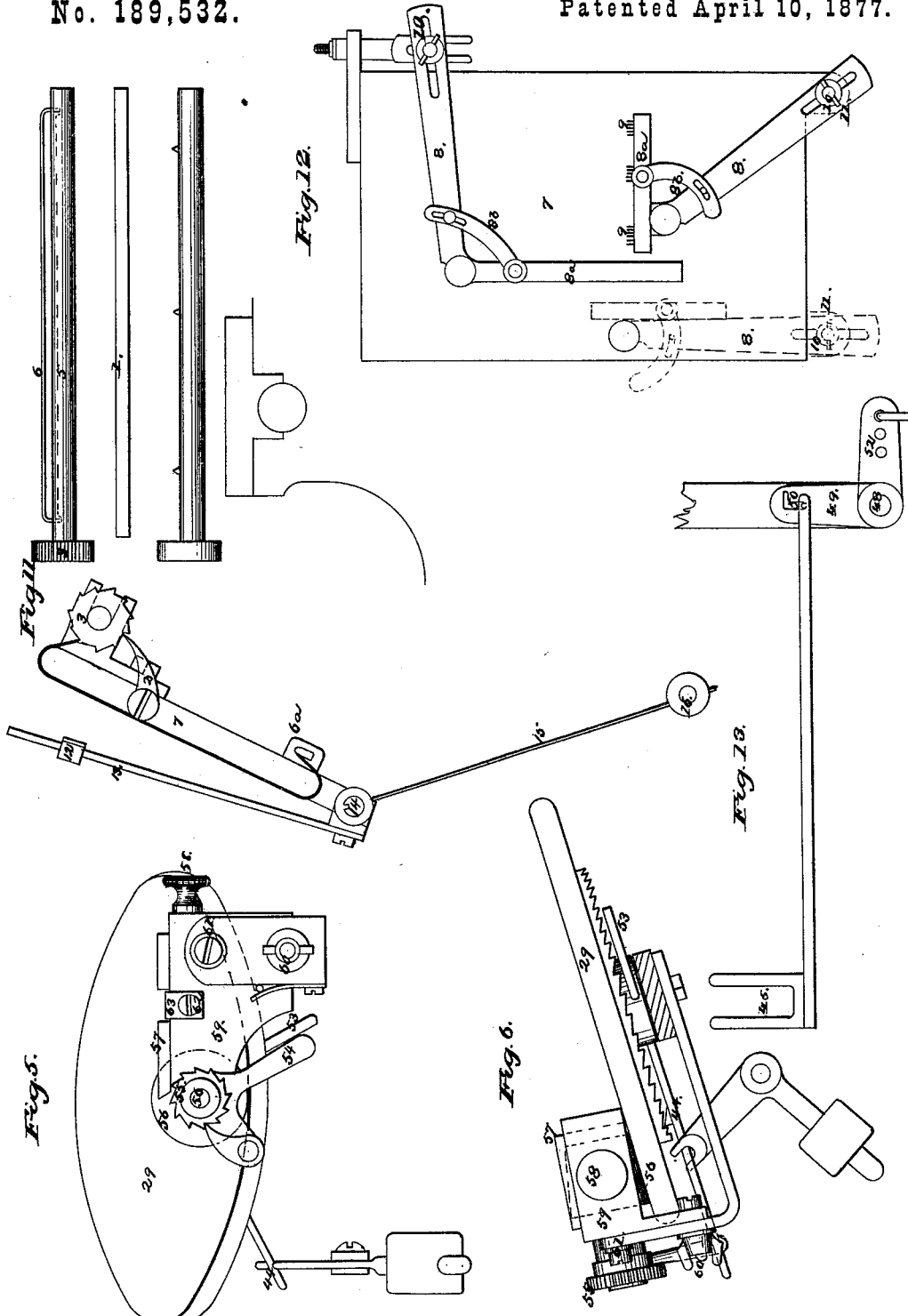

Attest:
Walter Bierley
Albert Crossley

Inventor:
Joseph Wade

UNITED STATES PATENT OFFICE.

JOSIAH WADE, OF HALIFAX, ENGLAND.

IMPROVEMENT IN PRINTING-PRESSES.

Specification forming part of Letters Patent No. **189,532**, dated April 10, 1877; application filed January 7, 1875.

To all whom it may concern:

Be it known that I, JOSIAH WADE, of Halifax, in the county of York, England, have invented certain Improvements in Printing-Presses, and for which Letters Patent were granted in England to this applicant December 20, 1872, No. 3,872, of which the following is a specification:

Figures 1 and 2 represent opposite side views, and 3 to 13, inclusive, detached views.

This invention relates to an improvement in printing-presses; and consists in the combination of mechanism, as hereinafter described, and as recited in the several claims.

In the front part of the frame A of the machine, immediately over the shaft A', carrying the driving-pulley and the fly-wheel 47, is journaled a shaft, 35A, Fig. 1, on which is loosely mounted a sleeve or barrel, 23, on ribs or lugs, to which is connected, by the usual adjusting-screws, the platen 7. On one end of the barrel 23 is fixed a toothed segment or wheel, 22, which gears with a similar segment, 17, fixed on a shaft, 18, journaled in the frame, back of the platen. On one end of the shaft 35A is keyed a wheel gearing with a pinion on the driving-shaft, and on the other end thereof is keyed a blank-wheel, 35, having on its inner side a cam, 20, on which rests a stud on the end of an arm, 19, of the shaft 18. By the revolution of the cam 20 the arm 19 is lifted so as to "web" the shaft 18, and, through the segment-gears, turn the platen from the inclined position in which it receives the sheet to a vertical position, in which it is held by a concentric portion of the cam, to receive the impression from the form on the oscillating bed. Backward from the barrel 23 extends a rib, 23A, the upper side of which, during the impression, and while the concentric portion of the cam is acting, rests against the shaft 18, and holds the platen steady. A spiral spring, 23B, connecting the rib with the main frame, holds the stud on the arm 19 in contact with the depressed portion of the cam while the platen is returned to its inclined position.

The gear-wheel on one end, and the blank-wheel on the other end, of the shaft 35A have crank-pins, which are connected by rods 27 to eccentric wrists on a shaft, 24, mounted in the type-bed frame 37, which extends downward

and is pivoted in the lower part of the main frame A. On one end of the shaft 24 is keyed a cam plate or arm, 33, Fig. 2, on which is swiveled a stud, 32, through which passes one end of a rod, 25, having its other end supported in a bracket, 30, on the frame A. Within this bracket the end of the rod bears against a screw, 26, having a milled bead, by which the position of the rod is adjusted. On the rod is fixed a stop-stud, 31, which lies in the path of the cam-arm 33, on the shaft 24. When the bed is drawn toward the platen by the crank-rods 27, the cam-arm 33 strikes the stud 31, and causes the eccentric shaft 24 to turn so as to give to the bed a motion additional to and independent of that received from the crank-rods, and the impression is made. One or more spiral springs, 34, Figs. 3 and 4, attached at one end to the bed-frame 37, and at the other to pins on the shaft 24, return said shaft after the action of the stop-stud on the cam-arm, to position with a projection, 34A, on the shaft, resting against studs 34B on the bed-frame.

By the adjustment of the rod 25 the force of the impression is very readily and accurately adjusted. By the same means the eccentric shaft may be so turned that an impression will be avoided while the machine remains in motion for the more thorough distribution of the ink by the continued action of the inking-rollers.

Through an opening in the top of the bracket 30 extends, from the rod 25, a pin, 25A, which is held by a spring, 25B, against the inner side of the opening, and prevents the turning of the rod under the pressure of the cam-arm 33. Using the pin as a handle, the rod may be turned by the operator, so as to throw its stop-stud upward out of the path of the cam-arm, and thus an impression be avoided more quickly than by turning the screw 26.

On the upper part of the bed-frame is mounted the usual ink-distributing disk 29, having on its under side ratchet-teeth, with which engages a spring-pawl, 44, Fig. 7, on a radial rod mounted loosely on the hub of the disk, and operated by a weighted swinging lever, Fig. 6. On a bracket on the bed-frame, extending to the rear side of the disk, is piv-

oted, at 61, Fig. 5, the ink-fountain frame 59, in which are mounted a conical roller, 56, radial to the disk, and back of the roller the fountain 57, the lower front edge of which acts as a doctor-blade, the fountain being adjusted with relation to the roller by a milled screw, 58. The fountain is secured in its frame by a screw, 62, and a clip, 63. On the screw being slackened the fountain may be removed to be cleaned or replaced by another containing ink of a different color. A spring on the bracket holds the fountain-roller in contact with the face of the disk; but the fountain and roller may be raised clear of the disk, and held in that position by a thumb-screw, 60. On the end of the fountain-roller is a ratchet-wheel, 55, with which engages a pawl on a swinging lever, 54, intermittingly operated by a finger, 53, connected to and moved by the radial pawl-rod.

The inking-rollers 28, Fig. 2, are journaled as usual in spring-rods, sliding in a frame, 36B, loosely mounted in the shaft 24, on which is also loosely mounted a segment lever, 36A, connected by a rod, 36, to a band surrounding the rim of the blank crank-wheel 35, Fig. 1. The roller-frame 36B is connected to the segment 36A by a screw-stud, 38, carrying a locking-lever, 39.

The head of the stud slides in a groove in the roller-frame, and its screw-threaded stem passes through a slot in the edge of the segment-lever to receive the threaded end of the lever which locks the frame and segment together, and thus the rollers are carried back and forth over the disk 29, and the form of type on the bed. By unlocking the stud the rollers will be left free to remain on the ink-disk, so as to afford space, and facilitate the placing of the form on the bed, and taking a first impression, and for other adjustments.

The roller-frame and the segment-lever may be connected by a pin, 39B, and collar, Fig. 10. The wheel on which the band of the rod 36 is supported may be eccentric, and thereby a motion be given to the roller-frame additional to that imparted by the oscillating motion of the bed-frame.

The roller-ways at the sides of the bed (or the runners on the rollers) are covered with leather or other suitable material to insure the rotation of the rollers. Such straps, 40, Fig. 1, are secured at the lower end of the way by pins 43, and at the upper end are hooked onto a pin on a screw-head, 41, held secure by a wing-nut.

A parchment tympan-sheet is stretched over the face of the platen, Fig. 11. Its lower end is formed into a loop, through which passes a rod, 1, placed in slots 6a at the lower rear edge of the platen. The other end of the sheet is secured to a spiked rod, or under a looped rod, which is pressed into a groove cut in the shaft 5. The turning of the upper rod stretches the tympan tight, and a pawl, 2, engaging a ratchet-wheel, 3, on the rod, holds it securely.

A finger, 12, extending transversely over the platen is adjustable on the usual finger 13, which is adjustably secured to the grooved bar 14, journaled at the lower edge of the platen, and rocked by a rod, 15, working through a swiveled stud, 16, on the frame A.

The gages 8 8a, Fig. 12, are adjustably secured to the face of the platen by clamp-screws 10, passing through slots in the gages, and slots in lugs 11 on the platen. The gages are in two parts, jointed together, as shown. On the part 8a is pivoted one end of a curved link, 8b, in the other end of which is a curved slot, through which passes a screw, tapped into the part 8, and holding the part 8a in any position to which it may be adjusted. Near the upper edge of the outer side of the part 8a are made a number of small holes, for the insertion of pins 9, under which is placed the edge of the sheet to be printed.

On the rear end of a shaft, 48, journaled in lugs on one side of the frame A, Fig. 1, is an arm, 49, receiving in a right-angled slot, 50, Fig. 13, a pin on the end of a transverse sliding bar, having at its outer end the belt-shifter, 45. Another arm, 52, on the shaft 48, is linked to a brake, 46, pivoted to the frame A, and lying under the fly-wheel 47.

The turning in one direction of a hand-lever, 51, on the front end of the shaft 48, shifts the belt from the driving to the loose pulley, and simultaneously applies the brake. A reverse movement of the lever releases the brake and returns the belt to the driving-pulley.

I claim—

1. The combination of the oscillating bed and the automatically-rocking eccentric shaft, mounted in the bed-frame, substantially as described.

2. The combination of the bed-frame, the crank-wheels, and connecting-rods, and the automatically-rocking eccentric shaft, substantially as described.

3. The oscillating bed and the rocking eccentric shaft, mounted in the bed-frame, and having a cam-arm in combination with the stop-stud, substantially as described.

4. The oscillating bed and the rocking eccentric shaft mounted in the bed-frame, and having a cam-arm, in combination with the stop-stud, the spring 34, and stops 34A 34B, substantially as described.

5. The combination of the oscillating bed, the rocking eccentric shaft, having a cam-arm, and the adjustable stop-stud, substantially as described.

6. The oscillating bed and the rocking eccentric shaft, having a cam-arm, with a swiveled guide-stud thereon, combined with the sliding rod, having a stop-stud thereon, substantially as described.

7. The sliding rod bearing a stop-stud and a pin, in combination with the cam-arm, the eccentric rocking shaft, and the oscillating bed, substantially as described.

8. The revolving shaft 35A, carrying a cam, and the crank-wheels oscillating the bed; the platen, sleeved on said shaft and provided with a segment-gear, 22, and the rock-shaft 18, carrying a segment-gear, 17, and having a crank-arm, 19, all combined and operating substantially as described.

9. The adjustable gage, provided with holes for receiving the sheet-holding pins, substantially as described.

10. The jointed adjustable gage, combined with the pivoted adjustable links, substantially as described.

11. The combination of the ink-roller frame

with mechanism substantially as described, for oscillating said frame, and a locking-nut, for connecting and disconnecting said frame with or from said mechanism, substantially as described.

12. The combination of the ink-fountain 57, adjusting-screw 58, roller 56, screws 60 and 62, and clip-piece 63, all as and for the purpose set forth.

JOSIAH WADE.

Witnesses:

WALTER BRIERLEY,
ARTHUR B. CROSSLEY.