

J. WALSH.
SAW-SHARPENER.

No. 189,534.

Patented April 10, 1877.

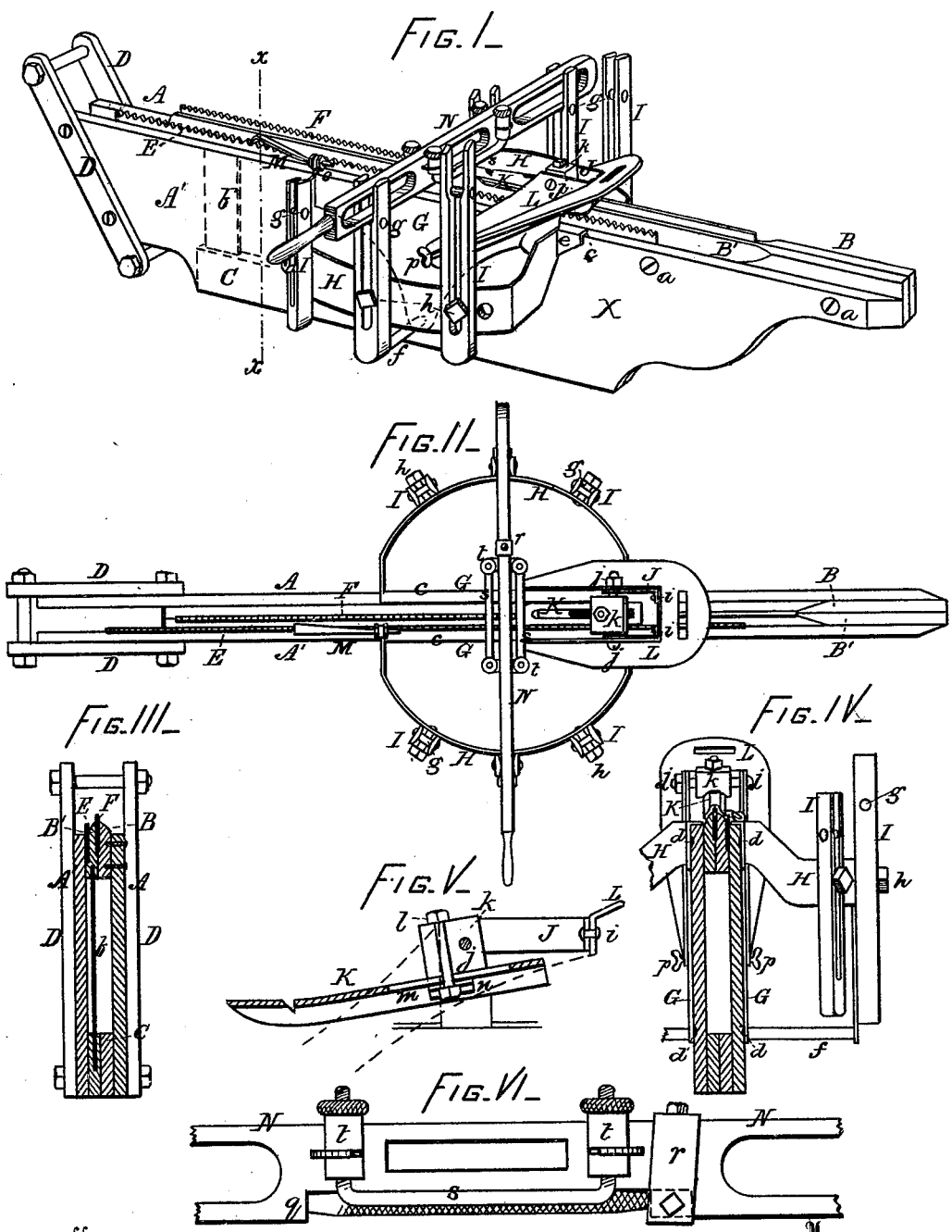

Witnesses

W. R. Wright - }
E. K. Nichols }

Inventor,
John Walsh,
By Thomas G. Orwig,
Attorney

UNITED STATES PATENT OFFICE

JOHN WALSH, OF NEWTON, IOWA.

IMPROVEMENT IN SAW-SHARPENERS.

Specification forming part of Letters Patent No. **189,534**, dated April 10, 1877; application filed October 5, 1876.

To all whom it may concern:

Be it known that I, JOHN WALSH, of Newton, Jasper county, Iowa, have invented a new and Improved Apparatus for Filing Saws, of which the following is a specification:

The object of my invention is to provide an apparatus for filing the teeth of saws, by which any person with little or no practical experience will be enabled to perform the necessary labor in an accurate manner, the whole forming an apparatus that is light, portable, and cheaply constructed. It consists of three separate and distinct parts—a clamp, a gage, and a file-holder, formed and co-operated as hereinafter fully set forth.

Figure 1 of my drawing is a perspective view of my entire apparatus, showing the different parts in position for operation. Fig. 2 is a plan view of the same. Fig. 3 is a sectional view of the clamp on the line *xx* of Fig. 1. Fig. 4 is an end elevation of the gage, showing the clamp in section. Fig. 5 is an enlarged view of the tooth-gage, showing the manner in which it is adjusted to the yoke. Fig. 6 is an enlarged view of the file-holder.

Similar letters of reference indicate corresponding parts in all the figures.

The clamp X is formed in the shape shown in Fig. 1, and is composed of two outside strips of wood, metal, or other suitable material, A A', and inside strips B, B', and C. The strips B B' extend a short distance above the outside pieces, and are beveled on the upper edge, as shown in Fig. 3. The outside pieces A A' are riveted or otherwise rigidly fixed to the lower strip C, and do not at any time require loosening; but the upper strips B B' are secured to the strips A A' by screws *a a* and clamp-pieces D D, so that when a saw is to be inserted the screws and clamp-pieces can be loosened sufficiently to allow the saw to be placed between the strips B B', and then screwed and bolted tightly in place. Between the inner strip B' and outside piece A' I place a toothed strap, E, which serves as a gage when filing the saw F, as hereinafter more fully described.

The strip *b* (shown in dotted lines in Fig. 1 and in Fig. 3) is for the purpose of holding the strip B' in place when the clamp X is loos-

ened to receive the saw, the strip B being held by rivets or otherwise secured to the piece A.

The gage is formed of two side plates, G G, which, by means of flanges *e e*, fit over and slide upon the upper edges of the clamp-pieces A A', and to prevent unnecessary friction, raised portions *d d d* are formed on the inner surfaces of the plates, which bear against the side pieces A A'. Secured to the sides of the plates G G at the points *e e*, and projecting out from the same, are the semicircular bands or standard-supports H H, on which the adjustable guides or standards I I are mounted. The curve of the bands forms that part of a circle which is best suited to obtain the angles required and allow convenient room for the movement of the file-holder in the standards. A short center arm on each side projects downward from the outside of the bands to the level of the lower extremity of the plates G G, to which it is connected by means of a light horizontal brace, *f*. The adjustable guides or standards I I are secured to the bands H H by bolts *h*, at such points as are found best suited to obtain the different angles required. It will, of course, be understood that one standard on each side, sliding and adjustable in a slot in the bands H H, will be but a modification of my arrangement; but I prefer to use three standards on each side, properly adjusted, as that will obviate the necessity of numerous changes, and thus save time and labor.

The standards I I have a slot extending almost down their entire length, wide enough at the top to receive the file-holder, which rests on the screw or pivot *g*, and from thence downward it can be made narrower. The upper part of the slot has rounded edges, to prevent the file-holder from binding when varied from a square position. The standards can, by means of this slot, be adjustable both vertically and at different angles.

J is a continuation of the side plates G G, forming an elbow-shaped arm, bent at right angles at its upper extremity, at which place it is slotted and secured to the yoke L by a bolt, *i*, passing through the slot, so that the plates G G can be adjusted to accommodate themselves to clamps of different thicknesses. The

arm J is also bolted to the yoke L by the bolt *j*, which bolt passes longitudinally through a square block, *k*, and which block, in turn, supports the tooth-gage K in the following manner: A second bolt, *l*, passes vertically through the block and through a slot, *m*, in the tooth-gage, and is then riveted to a plate, *n*, on the under side of the slot, which will thus allow the gage K to be adjusted to any desired length. The gage K is bent or formed into a semicircular shape, which allows it to slide on the rounded edges of the clamp-strips B B', before described; or the center groove may slide on the teeth. At the lower end of the yoke L are thumb-screws *p*, which serve to bind the yoke closely to the side plates G G, thus causing the yoke to act as a vise to hold all the parts firmly together.

M is a spring-catch, the object of which is, together with the gage-strap E, to regulate the movement of the gage, as hereinafter described. The catch at one end is bent at right angles to hold in the teeth of the strap E, and at the other end is rounded to pass through a hole in the bearing *o*, and, by means of nuts on either side, can be adjusted to different lengths.

N is the file-holder. (Shown in detail in Fig. 6.) The file is held in place by inserting one end in a cavity formed at *q*, and passing the other end in a small block, which is held in place by a band, *r*. The depth of cut is regulated by gage-rods *s s*, which can be raised or lowered, as required, by means of thumb-nuts *t t*.

The manner of operating my apparatus is as follows: The saw F and strip E being placed in their proper positions, the screws *a a* and clamp-pieces D D are tightened securely together. The strip E must have its notches or teeth correspond to the teeth of the saw to be filed. The clamp is now placed in a vise, or is held securely by other suitable means, and the gage placed in position, the standards being properly adjusted for the kind of cut required, and the spring-catch M fastened in the the first notch of the strip E. The file-holder is then placed between the proper standards, and a reciprocating motion given to it, by which the file cuts its way into the saw until stopped by the gage-rods *s s*. The spring-catch is then lifted and the gage moved along till the catch fastens in the next notch, when the filing is repeated, the depth of cut being always regulated by the gage-rods *s s*; and so the operation continues until the whole of the saw is filed in a perfectly true and even manner.

I claim as my invention—

The clamp X, constructed as shown and described, and strip E, in combination with side plates G G, spring-catch M, adjustable standards I I, file-holder M, gage-rods *s s*, and tooth-gage K, all arranged substantially as and for the purpose set forth.

JOHN WALSH.

Witnesses:

S. S. SMITH,
J. H. HARVEY.