

J. RIGBY.
GAS APPARATUS.

No. 189,575.

Patented April 17, 1877.

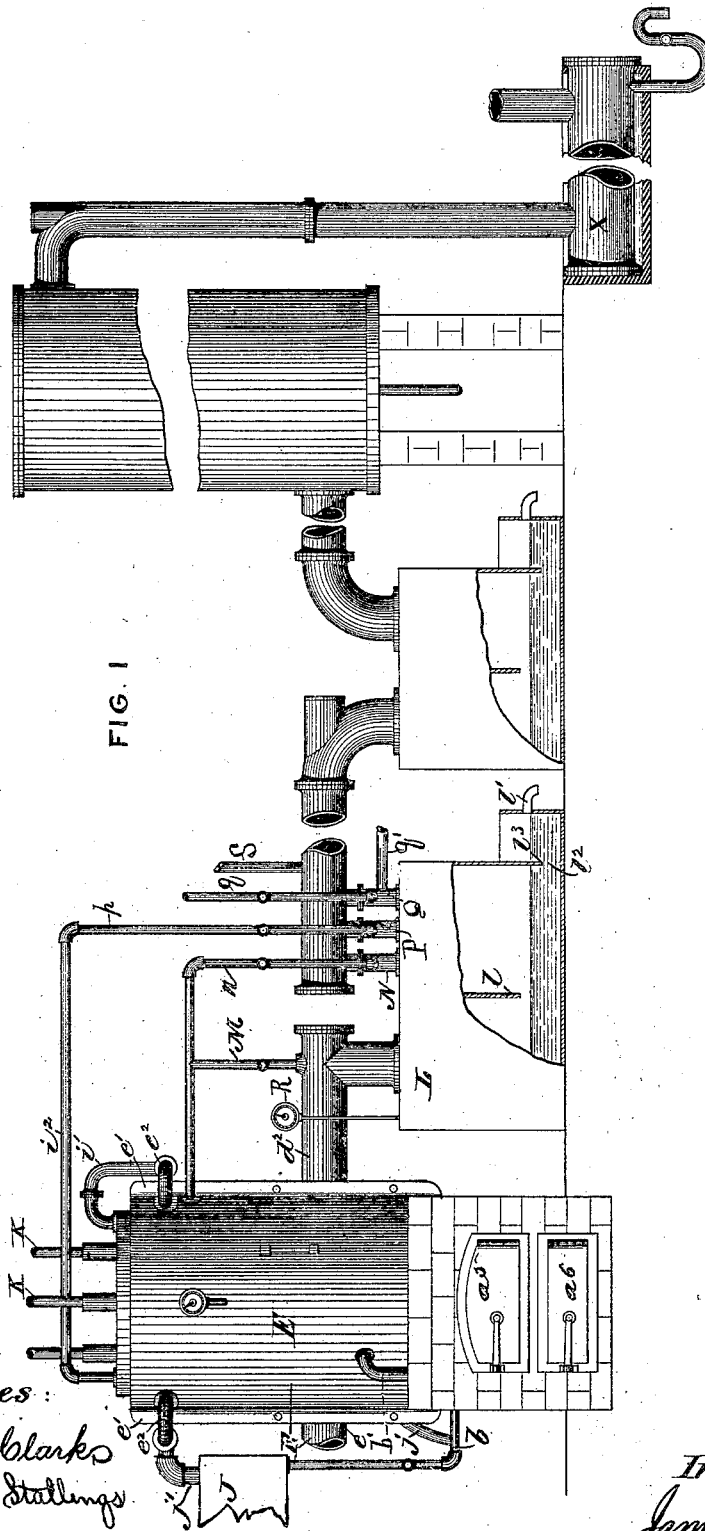

FIG. 1

Witnesses:

Harry C. Blanks
Minnie B. Stallings

Inventor
James Rigby

J. RIGBY.
GAS APPARATUS.

No. 189,575.

Patented April 17, 1877.

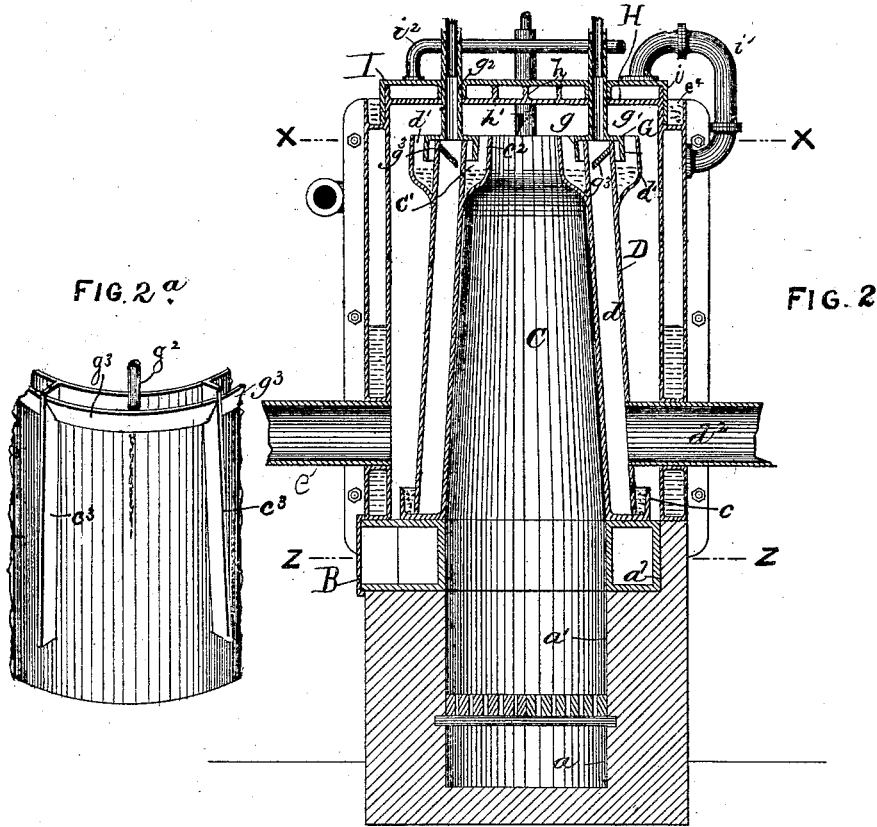

FIG. 2^a

FIG. 2

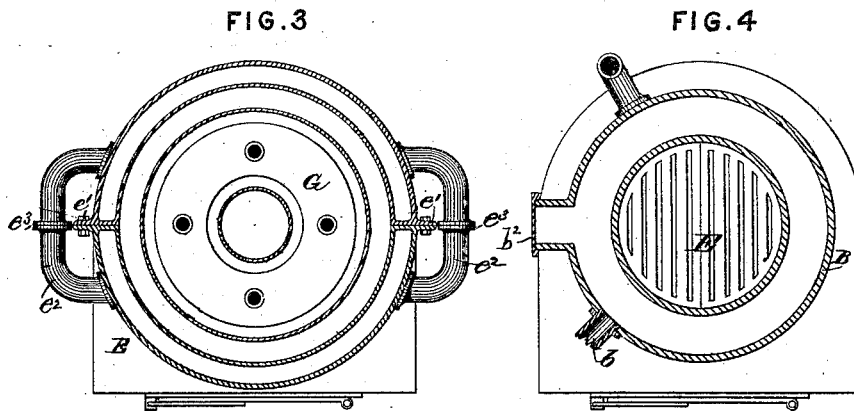

FIG. 3

FIG. 4

Witnesses:

Harry C. Clarke,
Miami B. Stallings

Inventor.

James Rigby

J. RIGBY.
GAS APPARATUS.

No. 189,575.

Patented April 17, 1877.

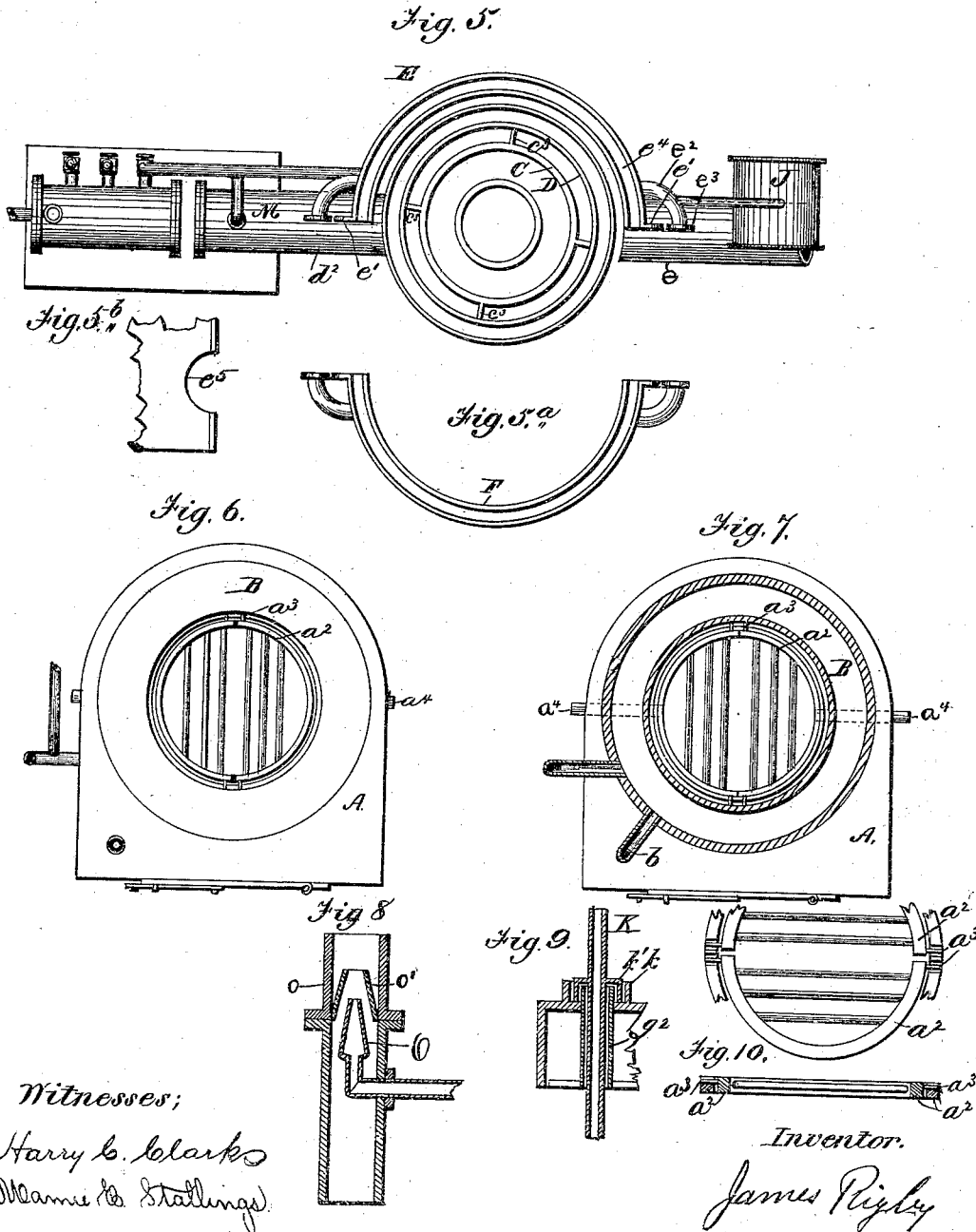

Witnesses;
Harry C. Clark
Mearns & Stallings

Inventor.
James Ripley

UNITED STATES PATENT OFFICE.

JAMES RIGBY, OF MONTREAL, QUEBEC, CANADA.

IMPROVEMENT IN GAS APPARATUS.

Specification forming part of Letters Patent No. 189,575, dated April 17, 1877; application filed March 19, 1877.

To all whom it may concern:

Be it known that I, JAMES RIGBY, a citizen of the United States, now residing at Montreal, Quebec, Canada, have invented new and useful Improvements in Apparatus for Making Gas; and I do hereby declare that the following is a full and exact description of the same, reference being had to the accompanying drawings, and to the letters of reference marked thereon.

This invention consists, mainly, in the special construction of the retort and the parts which inclose the same. It consists, further, also, in certain details of construction, all of which will be fully described hereinafter.

In the drawings, Figure 1 represents a front elevation of my improved apparatus; Fig. 2, a central vertical sectional elevation of the retort and the boiler inclosing the same; Figs. 3 and 4, transverse sectional plan of the same; Fig. 5, a plan view, representing the removable portion of the boiler detached; Fig. 6, a plan view of the base with the superstructure removed; Fig. 7, transverse sectional plan cut through the water-bridge; Fig. 8, a sectional elevation of the injector enlarged; Fig. 9, a sectional elevation of the joint uniting the pipes K to the pipe-sections g^2 ; and Fig. 10, views of the grate-sections detached.

To enable others skilled in the art to make and use my invention, I will now proceed to describe fully its construction and manner of operation.

A, Figs. 1 and 6, represents the base of the furnace, consisting of brick-work or masonry, of any suitable size, which is preferably made circular in its outline, with the exception of its front, as shown.

a , Fig. 2, represents the ash-chamber, and a^1 the fire-chamber; $a^2 a^2$, Figs. 7 and 10, the semicircular sections of a divided grate, each of which is provided with pivot-studs $a^3 a^3$, by means of which it is capable of swinging in a downward direction to drop the fire.

$a^4 a^4$, Fig. 7, represent removable pins, by means of which the grate is ordinarily held in place.

$a^5 a^5$, Fig. 1, represent doors, of any proper construction, for closing the openings into the fire and ash chambers, as shown.

a^6 , Fig. 2, represents an annular recess

formed within the upper part of the base, as shown.

B, Figs. 2, 4, and 7, represents a water-bridge, consisting of an annular hollow casting, adapted to fit into the annular recess a^7 in the furnace-base, which is supplied constantly with water through an inlet-pipe, b , Fig. 1, leading to the supply-tank, and an outlet-pipe, b^1 , leading to the boiler, as shown. b^2 , Fig. 4, represents a hand-hole opening, by means of which any deposit accumulating in the bridge may be removed. If desired, however, a blow-off cock may be used instead.

C, Figs. 2 and 5, represents the inner shell of the retort, consisting of a hollow cone, which is provided below with the annular seal cup or basin c , and above with the annular seal-cup c^1 , as shown.

$c^3 c^3 c^3$, Figs. 2 and 5, represent vertical flanges or partitions radiating from the cone, at equal distances apart, which extend downward upon the cone, but not its entire length.

D, Figs. 2 and 5, represents the outer shell of the retort, consisting of a hollow cone adapted to fit over the inner shell and inclose the intermediate space, to form the chamber d of the retort. Its lower edge rests in the basin or cup c , in which sand or mud is placed for the purpose of forming a tight joint.

d^1 represents a cup or basin formed upon its upper end, the purpose of which will be hereinafter referred to.

d^2 , Figs. 1, 2, and 5, represents a dip-pipe, through which the gas formed in the retort is conveyed to the first washer.

E, Figs. 1 and 5, represents what may be termed the stationary or fixed portion of the boiler, consisting of a hollow semi-cylinder resting upon the upper face of the brick-work, and secured thereto in any proper manner.

e represents a section of the smoke-pipe permanently attached thereto; $e^1 e^1$, ribs or flanges upon each side; and $e^2 e^2$, sections of circulation-pipes, having flanges $e^3 e^3$, by means of which they may be readily bolted to the fellow sections of the other half of the boiler, as shown in Fig. 3. If desired, these pipes may be made of copper or be provided with an expansion-joint, as may be preferred.

e^4 , Fig. 2, represents a seal basin or cup formed at the upper end of the boiler, in

which sand or other proper material may be placed to form a tight joint.

*e*⁵, Fig. 5^b, represents a semicircular recess adapted to inclose one-half of the dip-pipe, as shown.

F, Fig. 3 and Fig. 5, represents what may be termed the removable portion of the boiler, which is constructed in a similar manner to the portion E, and is adapted to unite therewith, to form one complete whole. The parts, when in place, are strongly secured together by bolts passing through the flanges, as shown in Fig. 3.

G, Fig. 2, represents a covering-plate provided with flanges *g*¹, adapted to extend into the basins *e*² *d*¹, as shown, by means of which the upper end of the retort is tightly closed.

*g*² *g*³, Figs. 2 and 9, represent pipe-sections extending through the cover-plate, as shown, by means of which oil from the main pipes is delivered to the retort.

These correspond in number with the chambers formed by the vertical flanges or partitions *c*³, and are so arranged as to discharge their contents at points centrally located between the partitions.

*g*³, Fig. 2^a, represents an apron or guide-plate, by means of which the oil is distributed toward the partitions and thrown directly upon the retort.

H, Fig. 2, represents a plate or disk having proper holes for the passage of the pipes *g*², as shown, which is provided on its upper surface with a series of division-plates, *h*, so disposed that an opening is formed at the end of each alternate plate, by which means a continuous passage-way of great length is formed, in the manner well understood.

This plate does not rest directly upon the top of the retort, but is held a little distance above it, for the purpose of forming a passage-way, *h*¹, for the products of combustion.

I represents the main cover-plate, having proper openings for the passage of the pipes *g*², and a flange, *i*, adapted to rest in the basin *e*¹ of the boiler, as shown.

This plate, in connection with the plate H, forms a superheating-chamber, into which steam is delivered from the boiler through the pipe *i*¹, and from which it is drawn, and conducted to the second injector by the pipe *i*².

J, Figs. 1 and 5, represents the supply-tank, connected by the pipe *b*, Figs. 1 and 7, with one end of the water-bridge, as before described, for the purpose of supplying the same with water, and by the branches *j* *j*¹, Fig. 1, above and below, with the steam-boiler, as shown.

K, Figs. 1 and 9, represents the pipes through which oil from the supply-tank is delivered to the retort. The construction of the joints, by means of which these pipes are united to the pipe-sections *g*², is peculiar.

k, Fig. 9, represents a cup or basin surrounding the upper end of the pipe-sections at the point where they protrude through the cover-plate.

*k*¹ represents an inverted cup, secured to pipe K at some distance from its end, which is adapted in size to fit within the cup *k*, the pipe K itself being adapted to slip into the pipe-sections *g*², as shown. When the parts are in place a very close joint is formed, which may be packed with sand, luting, or other proper material.

L, Figs. 1 and 5, represents the first washer, consisting of a box having the mid-feather *l* and basin *l*¹, with communicating opening *l*² and dip-pipe *l*³, as shown.

M, Figs. 1 and 5, represents a pipe discharging into the upper end of the vertical portion of the dip-pipe, by means of which live steam from the boiler is applied to the gas-current, for the purpose of softening the same, and throwing down its impurities into the washer-box.

N, Fig. 1, represents the first injector-pipe, through which live steam from pipe *n*, leading from the boiler, is discharged to the first injector, for the purpose of exhausting the gas from the first washer and the retort, and forcing it on through the remaining parts of the apparatus.

O, Fig. 8, represents the injector proper, consisting of a suitable nozzle of proper construction, which is centrally located in the injector-pipe, as shown.

o represents a pipe-section discharging into the second dip-pipe, leading to the second washer; and *o*¹, an injector-shield arranged over the injector-nozzle, as shown, the purpose of which will be hereinafter explained.

P represents the second injector-pipe, through which superheated steam from the pipe *p*, leading from the superheater, is discharged to the second injector, for the purpose of supplementing the action of the first injector, and also adding to the gas more or less of hydrogen from the superheater.

Q represents the third injector-pipe, the base of which rests upon the washer-box, but otherwise has no connection with it. This pipe receives steam from any proper point through the pipe *q*, for the purpose of creating the proper exhaust, to draw in hydrogen through pipe *q* from any proper source.

R represents a vacuum-gage, by means of which the condition of the first washer and the retort may be accurately known, and the injectors regulated accordingly, to increase or diminish the vacuum, if desired, according to the necessities of the case.

S represents a pipe, having a proper burner, serving as a try-light, by means of which the quality of the gas being produced may be readily ascertained, and any necessary changes in the proportions of the elements be made.

The remaining parts of the apparatus do not constitute any part of the present invention, and hence they will not be described.

The operation of this apparatus is substantially as follows:

The fire having been started in the furnace, the flames and heat will rise up through the center of the retort, pass over its top and down the sides of the same to the smoke-pipe, as indicated by the arrows. By this means the retort-chamber, where the gas is made, is exposed on every side to flame, and consequently is heated to a high temperature.

The oil from the tank is delivered, through the pipe K and pipe-sections g^2 , to the upper end of the retort, at a central point in each division, and being directed by the aprons onto its inclined surface, it runs downward thereon until converted into gas by the heat. By means of these divisions the oil is equally distributed to the retort on all sides. The gas formed therein, in consequence of the exhaust formed by the injectors, seeks the chamber formed in the lower end of the retort below the partitions, and passes off through the dip-pipe.

By the action of the injectors the gas is drawn from the retorts through the dip-pipe and first washer, and forced forward through the remaining parts of the apparatus.

By the action of the injectors, also, as well as the steam-jet in the dip-pipe, the impurities are thrown down into the washer. The operation of the former, in this respect, is much facilitated by the injector-shield, which serves to arrest the condensation-waters, and to throw them, together with the impurities, back into the washer.

The base of the retort is designed to be a permanent structure, which, when once erected, never need be materially disturbed. The superstructure may be readily removed, either in whole or in part, according to the circumstances of the case.

If it be desired to replace the water-bridge, a circumstance of rare occurrence, then the whole must be removed; but if it is desired simply to replace the retort, or to cleanse the same, then the fixed portions of the boiler, and the parts permanently connected thereto, may remain undisturbed, the remaining parts being readily removed and replaced without material loss of time.

By the employment of sand as a seal, a tight joint is obtained, which will endure the intense heat to which it is exposed.

Having thus fully described my invention, what I claim as new, and desire to secure by Letters Patent, is—

1. In combination with the permanent base A, the removable vertical boiler, composed of similar semicircular independent sections E and F, substantially as described.

2. In combination with the boiler having a removable section, F, the removable annular retort C D, having the central flue-passage, substantially as described.

3. In combination with the permanent base A and the relatively-fixed section E of the boiler, the removable section F and the removable annular retort C D, having a central flue-passage, as described.

4. In combination with the relatively-fixed section E, having recess e^5 , the removable shell D, having the outlet-pipe d^2 rigidly attached thereto, as described.

5. In combination with the boiler E F, having the seal-basin e^4 , the removable top plate H I, as described.

6. In combination with the permanent base, the removable superstructure and the removable annular bridge, as described.

7. In combination with the fire-chamber a^1 and the smoke-pipe e^1 , the annular retort C D, the cover-plate, and the inclosing-boiler, forming main and return flues, as described.

8. In combination with the retort, having a central passage, forming the main flue, the cover-plate and boiler, forming a return-flue, as described.

9. In combination with the conical shell, the removable shell D, forming the annular closed retort, as described.

10. The retort described, consisting of the shell C, with seal-cups c^1 , shell D, with seal-cup d^1 , and covering-plate G, as described.

11. In combination with the retort, the deflecting and distributing plates g^3 , as described.

12. The vertical retort, provided with the vertical partition-plates and independent oil-pipes, as described.

13. The removable cover-plates H I, having the vertical division plates h , forming a super-heating-chamber, as described.

This specification signed and witnessed this 19th day of March, 1877.

JAMES RIGBY.

Witnesses:

H. W. BEADLE,
MAMIE E. STALLINGS.