

J. BOND, Jr.
SHOE-SEWING MACHINE.

No. 189,599.

Patented April 17, 1877.

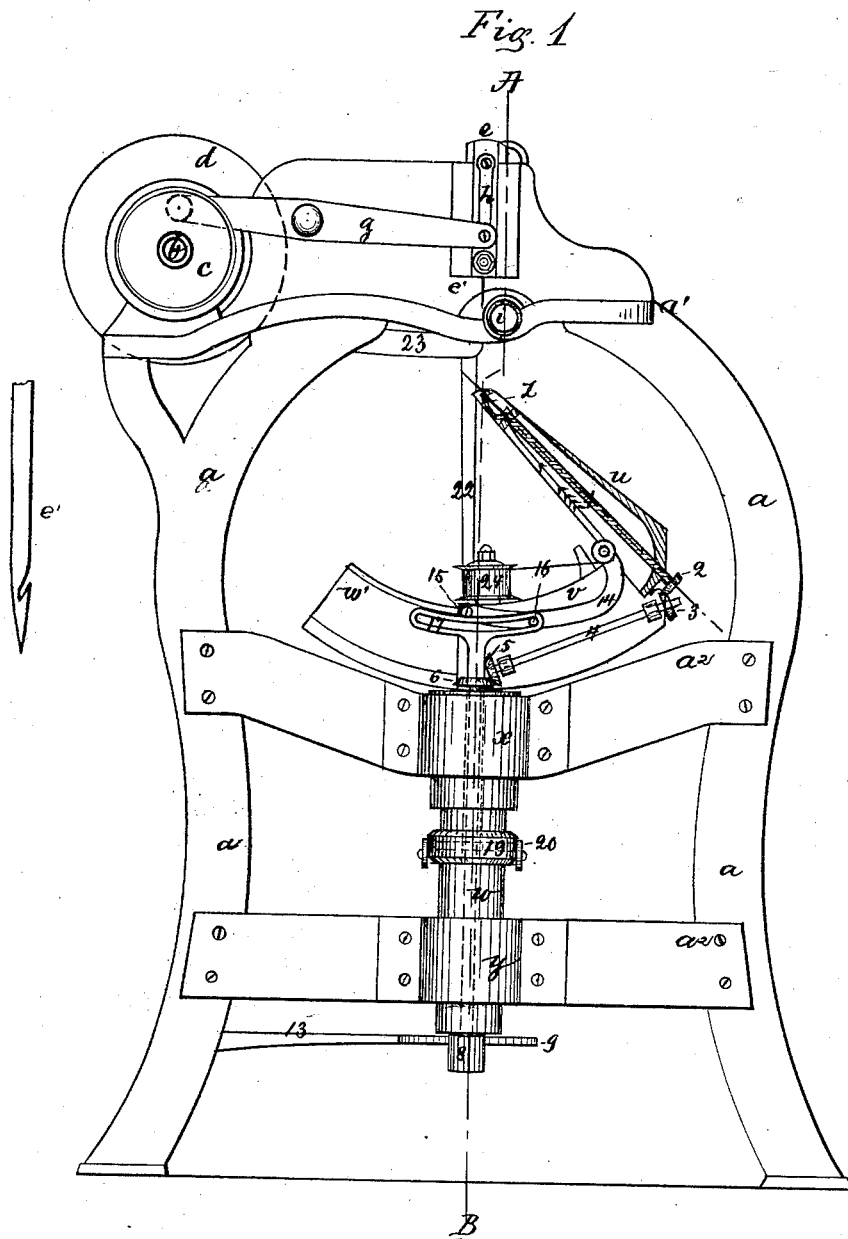

Witnesses:
John K. Beard
Fret Benjamin.

Inventor
Joseph Bond Jr.
By his atty
Charles E. Porter

J. BOND, Jr.
SHOE-SEWING MACHINE.

No. 189,599.

Patented April 17, 1877.

Fig. 2

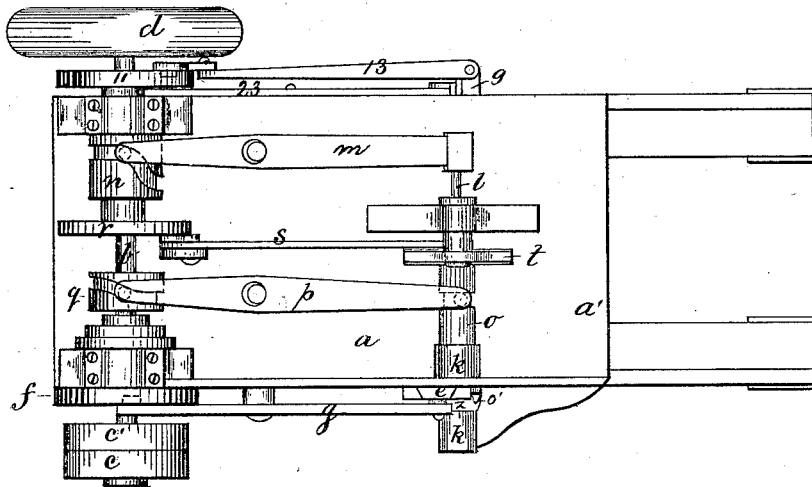

Witnesses:
 John R. Heard
 Fred Benjamin.

Inventor
 Joseph Bond Jr.
 By his attorney
 Charles E. Foster.

J. BOND, Jr.
SHOE-SEWING MACHINE.

No. 189,599.

Patented April 17, 1877.

Fig. 3.

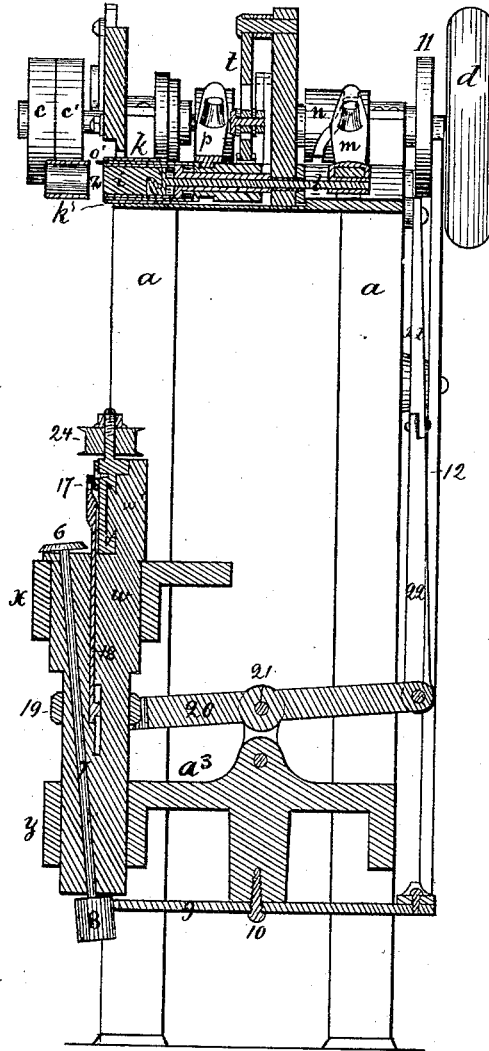

Witnesses:
John R. Heard.
Fred Benjamin

Inventor
Joseph Bond Jr.
By his atty.
Charles Foster

UNITED STATES PATENT OFFICE.

JOSEPH BOND, JR., OF WOONSOCKET, RHODE ISLAND.

IMPROVEMENT IN SHOE-SEWING MACHINES.

Specification forming part of Letters Patent No. 159,599, dated April 17, 1877; application filed December 7, 1876.

To all whom it may concern:

Be it known that I, JOSEPH BOND, JR., of Woonsocket, Providence county, Rhode Island, have invented certain Improvements in Shoe-Sewing Machines, of which the following is a specification:

The object of my invention is to sew together the soles and uppers of boots and shoes by two waxed threads, forming a lock-stitch; and this I accomplish by apparatus illustrated in the accompanying drawings, in which—

Figure 1 is a side elevation of the apparatus, partly in section; Fig. 2, a plan view; and Fig. 3 a sectional elevation on the line A B, Fig. 1.

The frame of the machine consists of side pieces *a*, supporting a bed-plate *a*¹ and cross-pieces *a*² *a*³. The bed-piece *a*¹ supports a shuttle-race, consisting of two sections, *k* *k*, guiding a cylindrical shuttle, and cams upon a driving-shaft, *b*, impart motion to the said shuttle and to a hook, *o*¹, as in the machine for which Letters Patent of the United States were granted to Hurtu & Hautin December 21, 1869.

To bearings *x* *y* of the cross-bars *a*² is fitted, so as to revolve and slide freely, a spindle, *w*, carrying a segment, *w*¹, supporting an adjustable slide, *v*, from which extends a hollow horn, *u*. A spindle extending through the horn carries at the upper end an eye-pointed looper, *z*¹, which is driven from a shaft, 7, extending through the spindle *w*, and operated from a cam on the driving-shaft through the medium of a lever, 12, vibrating segment 9, and elongated pinion 8, as shown in Fig. 3. The lower thread from the bobbin 24, carried by the slide *v*, passes around the grooved pulley on a thread-controlling lever, 14, hung to the slide *v*. A pin, 16, on the lever 14, extends into a slot, 17, in the cross-head of a bar, 18, sliding in the spindle *w*, and connected by a cross-pin to a ring, 19, sliding on the spindle, and operated from the driving-shaft through the medium of levers 20 and 22. A bar, *e*, sliding vertically between guides on the frame, and operated from the driving-shaft, carries the needle or thread carrier *e*¹, which is upon a line central with the axis of the spindle *w*, and adjacent to the opening *z*, between the two sections of the shuttle-race.

As the construction of the parts connected with the shuttle, and for distending the lower thread for the passage of the loops of the shuttle without contact, is essentially the same as in the before-mentioned patented machine of Hurtu & Hautin, it will be sufficient for present purposes to describe only the operations of these parts.

The shoe being placed upon the horn in the usual position, and properly adjusted by turning the spindle *w*, the latter is raised so as to press the shoe firmly against the lower side of the plate *a*¹, and the driving-shaft is set in motion, when the operations will be as follows: The thread-carrier *e*¹ will first descend through the leather to a position to receive a loop of the lower waxed thread, which is placed in the eye of the carrier by the operation of the looper *z*¹. The needle then rises and carries the loop to a position to be caught by the hook *o*¹, which, as it revolves, spreads the loop upon the outside of the sleeve or ring *o*, to which it is attached, when the shuttle passes across the opening *z*, carrying its waxed thread through the loop, which is released by the retraction of the sleeve *o*. The lever 14 now descends, drawing down the loop of under thread, and with it the loop of upper thread, so as to lock the two in or at the surface of the material, the shuttle meanwhile returning to its first position, as shown in Fig. 3.

These operations are continued until the work is finished, the horn being adjusted as is necessary.

Owing to the bar 18 being carried by the spindle *w*, and having a slot, 17, it will always occupy the same position relative to the said controlling-lever 14, whatever may be the position to which the segment and horn are adjusted.

By the above-described operations two waxed threads are combined, forming a lock-stitch, uniting the sole and upper of a boot or shoe, a result which is due to the combination, with the horn, looper, and thread-carrier, of devices for so spreading the lower waxed thread as to permit the passage of the shuttle without contact with the loop.

I do not here claim a boot or shoe in which the upper and sole are united by a lock-stitch of two waxed threads, as this will form the

subject of a separate application for Letters Patent; neither do I here claim any of the peculiar mechanism illustrated for operating the shuttle and hook.

It will be apparent that, without departing from the principle of my invention, various appliances may be employed in place of those described for effecting the interlocking of the threads, in the manner set forth; without, therefore, limiting myself to such appliances—

I claim—

1. The combination, in a shoe sewing machine, of a horn containing a looper carrying a waxed thread, and provided with a thread-controller, a thread-carrier penetrating the material from the outside, and carrying the lower waxed thread through the same in the form of a loop, a shuttle reciprocating above the horn, a tubular race, *k k*, and a rotating and sliding sleeve, *o*, and hook *o'*, whereby the

said loop is opened to permit the passage of the shuttle, without contact, through the loop, and the loop is drawn, with the upper waxed thread, to the material, all as set forth.

2. The combination, in a shoe-sewing machine, of a horn, a thread-carrier within the same, and a thread "take-up" mechanism for operating the thread passing through the horn to the carrier, substantially as set forth.

3. The combination of a horn, take-up lever 14, and slotted bar 18, all carried by the horn, substantially as set forth.

In testimony whereof I have signed my name to this specification in the presence of two subscribing witnesses.

JOSEPH BOND, JR.

Witnesses:

CHARLES E. FOSTER,
WM. L. BRAMHALL.