

J. C. COONLEY.  
TUMBLING BARRELS.

No. 190,009.

Patented April 24, 1877.

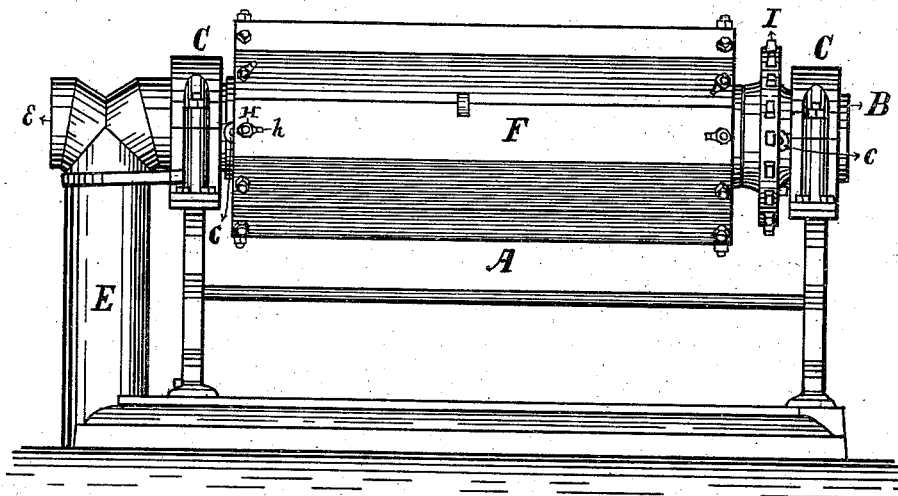

Fig. 1.

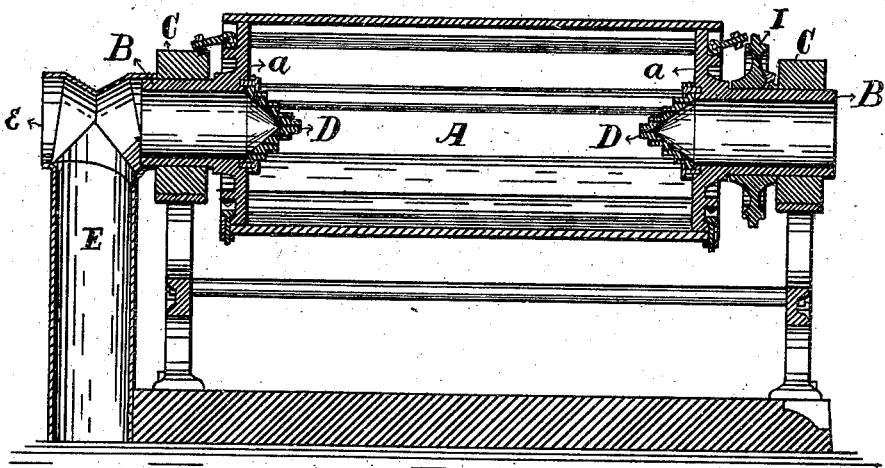
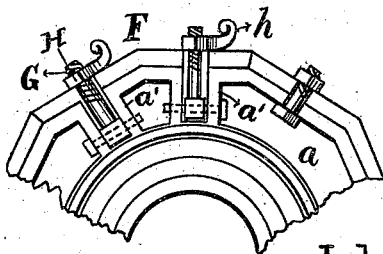

Fig. 2.

Fig. 3.



Attest  
H. C. Keolis.  
E. S. Lloyd.

Inventor.  
John C. Coonley.  
By *Robert M. ...*  
Attys

J. C. COONLEY.  
TUMBLING BARRELS.

No. 190,009.

Patented April 24, 1877.

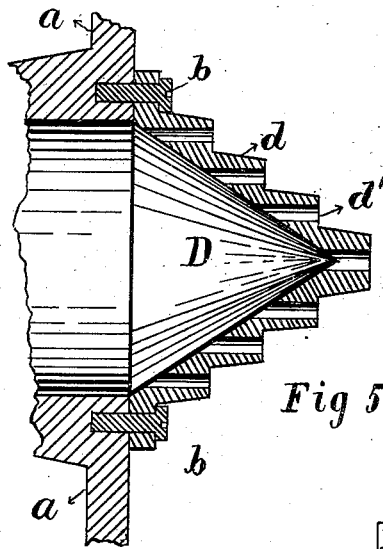

Fig 5

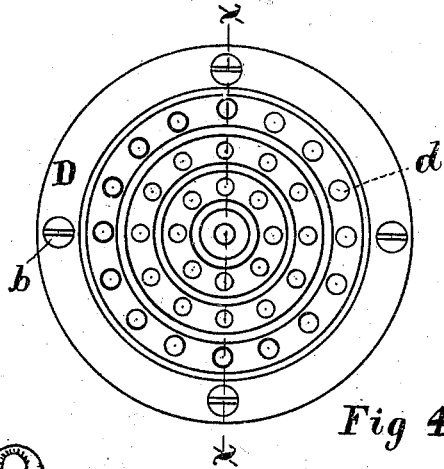

Fig 4

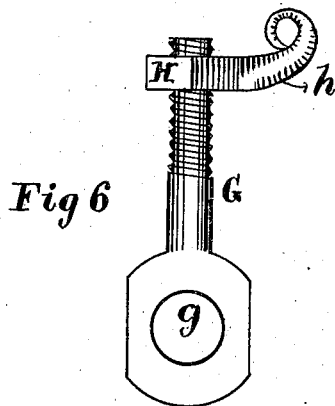

Fig 6

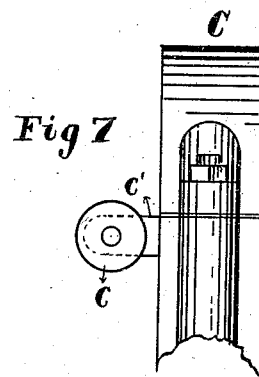

Fig 7

Fig 8

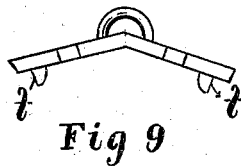
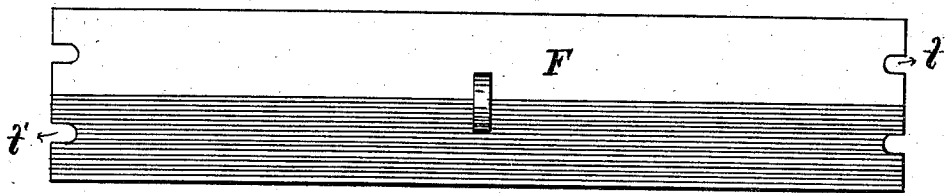

Fig 9

Attest  
*W. G. Coonley.*  
*E. S. Lloyd.*

Inventor  
John C Coonley  
By *Robert Thacher*  
Attys

# UNITED STATES PATENT OFFICE.

JOHN C. COONLEY, OF CHICAGO, ILLINOIS.

## IMPROVEMENT IN TUMBLING-BARRELS.

Specification forming part of Letters Patent No. **190,009**, dated April 24, 1877; application filed March 26, 1877.

*To all whom it may concern:*

Be it known that I, JOHN C. COONLEY, of Chicago, in the county of Cook and State of Illinois, have invented a new and useful Improvement in Tumbling-Barrels, which is fully described in the following specification, reference being had to the accompanying drawings, in which—

Figure 1 represents a side elevation of the machine; Fig. 2, a lateral vertical section of the same; Fig. 3, a detailed view on an enlarged scale of one end of the barrel, showing the device for securing the cover; Fig. 4, an interior end view of the perforated cap which covers the aperture in the end of the barrel; Fig. 5, a sectional view of the same, attached to the barrel, taken on the line X X, Fig. 4; Fig. 6, a plan view of the hinged bolt for fastening on the cover; Fig. 7, a detailed view of a portion of the standard with an anti-friction roller attached thereto, and Figs. 8 and 9 a plan and end view, respectively, of the cover.

My invention relates to an apparatus for dry tumbling. In the tumbling-barrels usually employed for cleaning small castings without the use of water, the tumbler is either close or open to the room in which it is placed. In the former case, the accumulation of dust very soon interferes with the successful operation of the machine

In the latter case the shell of the barrel is generally perforated with a large number of holes, and the dust escapes directly into the room where the tumbler is placed, making the air exceedingly uncomfortable and unhealthy for those who work therein.

The object of my invention is to obtain a machine in which all the advantages of a closed tumbling-barrel are retained, and at the same time the dust is removed at once therefrom through suitable openings, and conducted out of the room without vitiating the air therein.

The invention consists in a tumbling-barrel closed at all points except the ends, in which there are openings covered on the inside by perforated conical-shaped caps, and at one end of the barrel connected on the outside with a suction-pipe, by means of which a continual draft through the barrel is produced.

It also consists in various devices and com-

binations of devices, all of which will be hereinafter more fully set forth.

In the drawings, A represents a tumbling-barrel, which is constructed so as to be tightly closed up after the castings are placed inside, with the exception of the ends or heads of the barrel.

Circular apertures are made through the ends *a* of the barrel, from which circular flanges B extend outward, and constitute the journals of the barrel, being mounted in suitable bearings upon standards C. The journals are consequently tubular, and are open at their outer ends, as shown in Fig. 2 of the drawings, while at the inner ends they communicate directly with the interior of the barrel.

Conical-shaped caps D are placed over the openings through the ends of the barrel, being arranged upon the inside of the latter, and attached by screws to the inner faces of the heads *a*.

The outer surface of these caps is stepped or rabbeted, as shown in the drawings, the several segments *d* thus formed being inclined upon the outer surface to represent sections of a cone, as shown in Fig. 5 of the drawings. Through each of these segments perforations *d'* are made entirely around the section, which establish direct communication between the hollow journals B and the interior of the barrel.

The caps D, being attached by screws *b* to the heads of the barrel, may be readily detached therefrom for repairs or any other purpose required. One of the tubular journals B is left open into the room in which the machine stands, but the other is connected at its outer end with a pipe, E, which is carried outside of the room and is connected with a fan or any other suitable suction device, by means of which a continual current of air may be established from the room into and through the barrel and out through the suction-pipe E, the air passing through the holes *d'* in the caps D, which are large enough to permit the passage of the dust from the castings, which is, therefore, carried out of the barrel with the current of air and conducted away outside of the room by the suction-blast.

The suction-pipe E is shown in the draw-

ings with two branches, *e*, at its upper end. This is for the purpose of connecting two barrels with the same pipe, if desired, the open branch *e* being connected for this purpose to the hollow journal of another tumbling-barrel arranged on its side in the same manner as described above.

In order to permit the introduction of castings into the barrel, a section, *F*, of the case is made removable, so as to be used as a cover or door. This cover has flanges *f* upon its inside surface, which fit between projecting flanges from the adjacent sections on which the edges of the cover rest, and at each end of the cover are shallow recesses *f'*, as shown in Fig. 8 of the drawings. The bolts *G*, by means of which the cover is fastened in place upon the barrel, are elongated and provided with an eye, *g*, at one end, as shown in Fig. 6 of the drawings. By means of this eye the bolts are pivoted to the ends *a* of the barrel, the latter being provided with flanges *a'* upon the outside to receive the pivot-bolts, as shown in Fig. 3 of the drawings. The outer ends of these bolts have a screw-thread cut upon them, and are fitted with nuts *H*, which are provided with a projection, *h*, at one side, which serve as handles for turning the nuts.

When the cover *F* is placed upon the barrel the bolts *G* are swung up and their upper ends enter the recesses *f'* in the ends of the cover, when the nuts *G* are turned down upon the cover, as shown in Fig. 3 of the drawings, thereby securing the latter very firmly in position. A sprocket-wheel, *I*, is attached to one of the journals of the barrel, by means of which the latter is revolved by a suitable chain, but any other device suitable for this purpose may be employed.

At the upper end of the standards *C* a small anti-friction roller, *c*, is mounted upon a short stud, *c'*, projecting from the inner side of the standard, and on each side of the barrel. At one end of the barrel these rollers are arranged to rest against the outer face of the wheel *I*, but at the other end they rest against a circular flange on the end of the barrel; or if the device for revolving the barrel should be arranged outside of the standard, the rollers should be arranged to rest against the flanges at each end of the barrel.

The interior of the barrel is provided with ribs, if desired, in the ordinary way.

It is evident that in the operation of the mechanism described above, the dust, arising within the barrel as the castings are tumbled by the rotation of the latter, will be carried out of the barrel by the suction-blast, which may be made as strong as desired, and conducted through the pipe *E* to some point outside of the room in which the tumbler is in operation, and, in fact, outside of the building, if desired. As the suction is directly through the barrel there is no accumulation of dust in the latter, and the cleaning of the castings is, therefore, effected much more rap-

idly than with a tumbler of ordinary construction. At the same time there is no escape of dust into the room; but, on the contrary, there is a constant draft out of the room through the barrel, so that the workmen are protected from all deleterious effects of the dust from the tumbler escaping into the room, and at the same time the latter is, to some extent, ventilated.

The peculiar form of the conical caps *D* is designed for the purpose of obtaining air-passages directly through the caps into the barrel, but at different distances from the heads, so as to prevent clogging, and the inclination of the surface is also intended to prevent the accumulation of dust upon the caps.

The cover is readily removed, whenever desired, by simply loosening the nuts *H* slightly and swinging down the bolts *G*, and the latter, when turned down in the position shown in Fig. 2 of the drawings, will serve as stops to prevent the rotation of the barrel, the projections *h* of the nuts being turned so as to catch into recesses or against projections on the standards *C*. The rollers *c* steady the barrel in its revolution, so that there is no wobbling motion or unnecessary strain upon the journals and their bearings.

Having thus described my invention, what I claim as new, and desire to secure by Letters Patent, is—

1. The close tumbling-barrel *A*, in combination with tubular journals *B* communicating with the interior of the barrel, and a suction-pipe, *E*, leading out of the room and connected to one of the tubular journals; while the other is left open, substantially as and for the purpose set forth.
2. The tumbling-barrel *A*, in combination with the tubular journals *B*, and conical perforated caps *D*, substantially as and for the purpose set forth.
3. The conical cap *D*, constructed with its exterior surface stepped, as described, and provided with a series of perforations through each segment or section, substantially as set forth.
4. The cover *F*, having recesses *f'* in its ends, in combination with the pivoted bolts *G* and nuts *H*, substantially as and for the purpose set forth.
5. The friction-rollers *c* on the standards *C*, in combination with the tumbling-barrel *A*, provided with a guideway, against which the rollers rest, substantially as and for the purpose set forth.
6. The closed tumbling-barrel *A*, in combination with the tubular journals *B*, conical perforated caps *D*, constructed as described, and the suction-pipe *E*, substantially as and for the purpose set forth.

JNO. C. COONLEY.

Witnesses:

WILLIAM D. EWART,  
L. A. BUNTING.