

W. F. THOMAS.
SEWING-MACHINE.

Patented April 24, 1877.

No. 190,098.

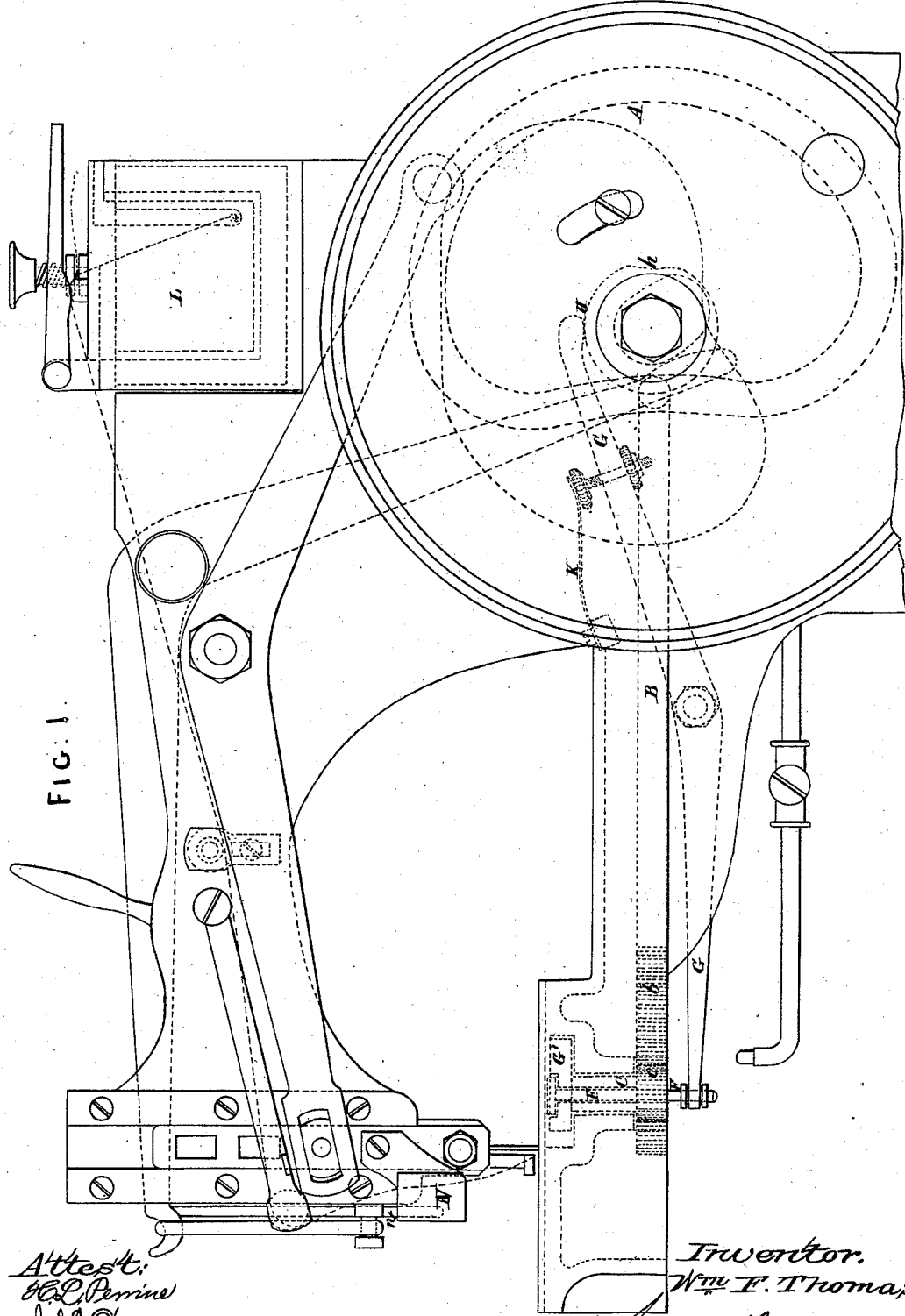

FIG. 1.

Attest:
H. P. Perrine
J. L. Groulx

Inventor.
Wm. F. Thomas.
James L. Norris
 Attorney.

W. F. THOMAS.
SEWING-MACHINE.

No. 190,098.

Patented April 24, 1877.

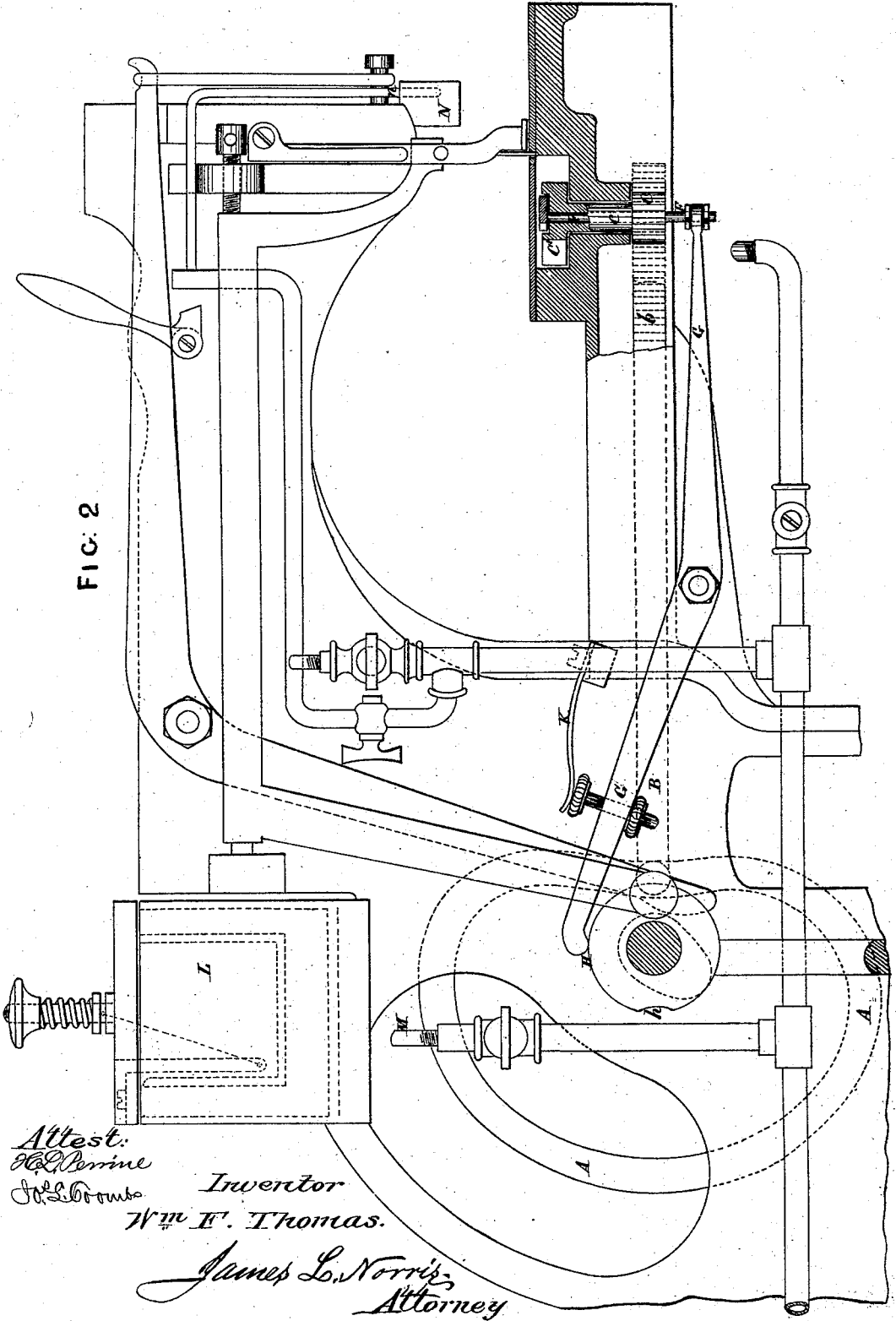

FIG. 2

Attest.
H. L. Perrine
J. S. Brown

Inventor
Wm F. Thomas.

James L. Norris,
Attorney

W. F. THOMAS.
SEWING-MACHINE.

No. 190,098.

ented April 24, 1877.

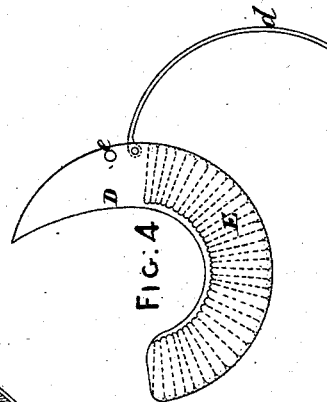
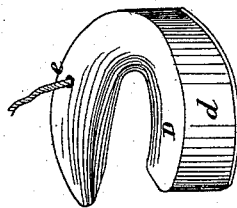
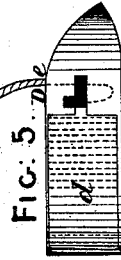
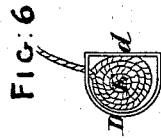
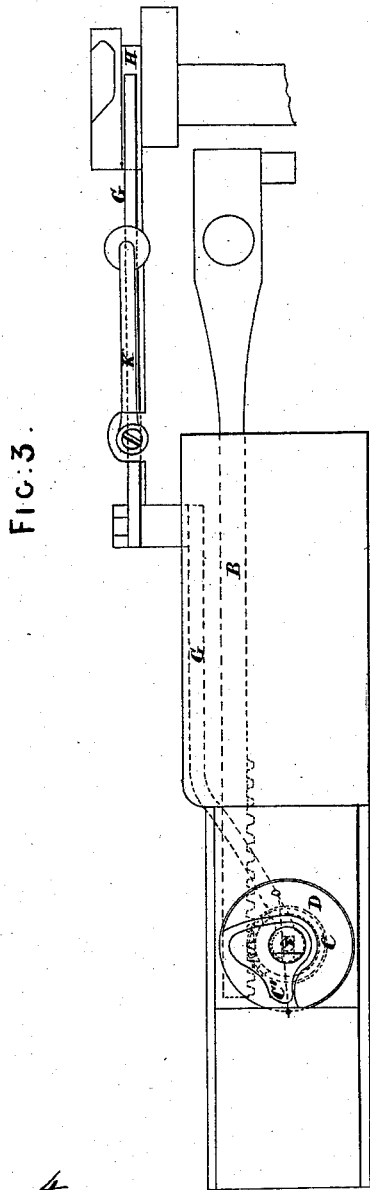

Attest:
Edw. Perrine
J. S. Coombs

Inventor.
 W^m F. Thomas.

James L. Norris,
 Attorney.

UNITED STATES PATENT OFFICE.

WILLIAM F. THOMAS, OF LONDON, ENGLAND.

IMPROVEMENT IN SEWING-MACHINES.

Specification forming part of Letters Patent No. **190,098**, dated April 24, 1877; application filed January 16, 1877.

To all whom it may concern:

Be it known that I, WILLIAM FREDERICK THOMAS, of No. 1 Cheapside, in the city of London, England, have invented an Improvement in Sewing-Machines; and do hereby declare that the following description, taken in connection with the accompanying drawings, hereinafter referred to, forms a full and exact specification of the same, wherein I have set forth the nature and principles of my said improvement, by which my invention may be distinguished from others of a similar class, together with such parts as I claim and desire to secure by Letters Patent—that is to say:

This invention relates to an improvement in lock-stitch sewing-machines, particularly such as are applied to the stitching of leather, or other purposes for which waxed threads are employed.

I provide a tubular shuttle, bent to a circular curvature, with a pointed end for entering the loop of the needle-thread; and into this shuttle I insert the under thread as a cop, which bends to the curvature of the shuttle. I place the shuttle in a circular race formed under the table of the machine, in such a position that the needle descends in a chase at the side of a race. A spindle mounted in the center of the race, and having on it an arm for driving the shuttle, receives a reciprocating rotary motion from a cam, such motion being properly timed, so that the shuttle is caused to enter the loop of the needle-thread. During the passage of the shuttle through the loop the latter has to slip only along the inner periphery of the shuttle, which is short, and presents a curvature that renders the slip easy. As the shuttle rotates, its thread is carried across the central part of the race; and in order to provide the necessary tension I cause the shuttle-thread to be pressed against the cover of the race by a lever acted on by an adjustable spring, the pressure of the spring being relieved, when required, by the action of a cam.

Figure 1 represents a front view, and Fig. 2 a back view, (partly in section,) of a wax-thread sewing-machine embodying my improvements. Fig. 3 is a plan of the lower arm, on which the material to be sewed is placed. Figs. 4, 5, 6, and 7 represent, respectively, a

plan, a side view, a transverse section, and a perspective view of the shuttle.

The movements of the needle and feed are effected by cams in the ordinary way. A cam, A, on the main shaft of the machine, works a sliding bar, B, on which is a toothed rack, *b*, gearing with a pinion, C, the axis *c* of which projects upward into the middle of the circular shuttle-race, and has on it a shuttle-driver, *c'*, so that at each revolution of the main shaft the shuttle-driver is caused to make a partial rotation—about three-quarters of a whole revolution—forward and backward. The shuttle D is of the form shown in section at Fig. 6, with a flat side toward the needle, and the opposite side rounded. A portion of the flat side *d* is hinged, so as to form a lid, which is shown opened out in Fig. 4, for the purpose of placing within the shuttle the cop of under thread E, which is readily bent to lie in the curved shuttle. The end of thread taken from the interior of the cop is passed down through a hole, and then up again, so as to issue from the upper side of the shuttle at *e*. The spindle of the shuttle-driver is bored up, and a small spindle, F, carrying a button at top, is fitted to work vertically therein without revolving. The lower end of the spindle is screwed into a square nut, and secured therein by a lock-nut, and this square nut is held in the fork of a lever, G, the end of which rests on the edge of a cam, H. A spring, K, adjustable by screws, presses down the one end of the lever G, thereby forcing the button of the spindle F up to the cover of the shuttle-race whenever the hollow *h* of the cam H presents itself to the end of the lever G. The needle-thread may be taken from a reel in the ordinary way, having been previously waxed; or it may be waxed as it is used by passing it through a pot, L, containing wax, which pot is placed in a jacket containing oil heated by a gas-flame, M. As the thread on its way from the pot L to the needle is cooled, I prefer to pass it through a tube, N, close to the needle, against which tube, as it oscillates upward and downward with the needle, a small gas-jet, *n*, plays.

Although I have shown in the drawings the shuttle working in its circular race horizontally on the inner side of the needle, it is

obvious that it might be arranged to work on the other side of the needle, and also in a vertical instead of a horizontal plane.

I am aware that a shuttle for sewing-machines has been constructed of an annular tubular ring having a heel and point, the heel part being adapted to be opened for the insertion of a bobbin or a cop, and such I therefore disclaim.

Having thus described the nature of my invention, and in what manner the same is to be performed, I claim—

1. The combination of the sliding spindle F, lever G, spring K, and operating-cam H with the cloth-plate of a sewing-machine, substantially as and for the purpose described.

2. The segmental shuttle D, constructed with an open outer portion, in combination with the flat side d, hinged to the shuttle, and forming a lid to such open side, as and for the purpose described.

In testimony whereof I have signed my name to this specification in the presence of two subscribing witnesses this 29th day of December, 1876.

W. F. THOMAS.

Witnesses:

CHAS. D. ABEL,
OLIVER IMRAY.