

G. McKAY.

PROCESS OF MAKING SHOES.

No. 190,153.

Patented May 1, 1877.

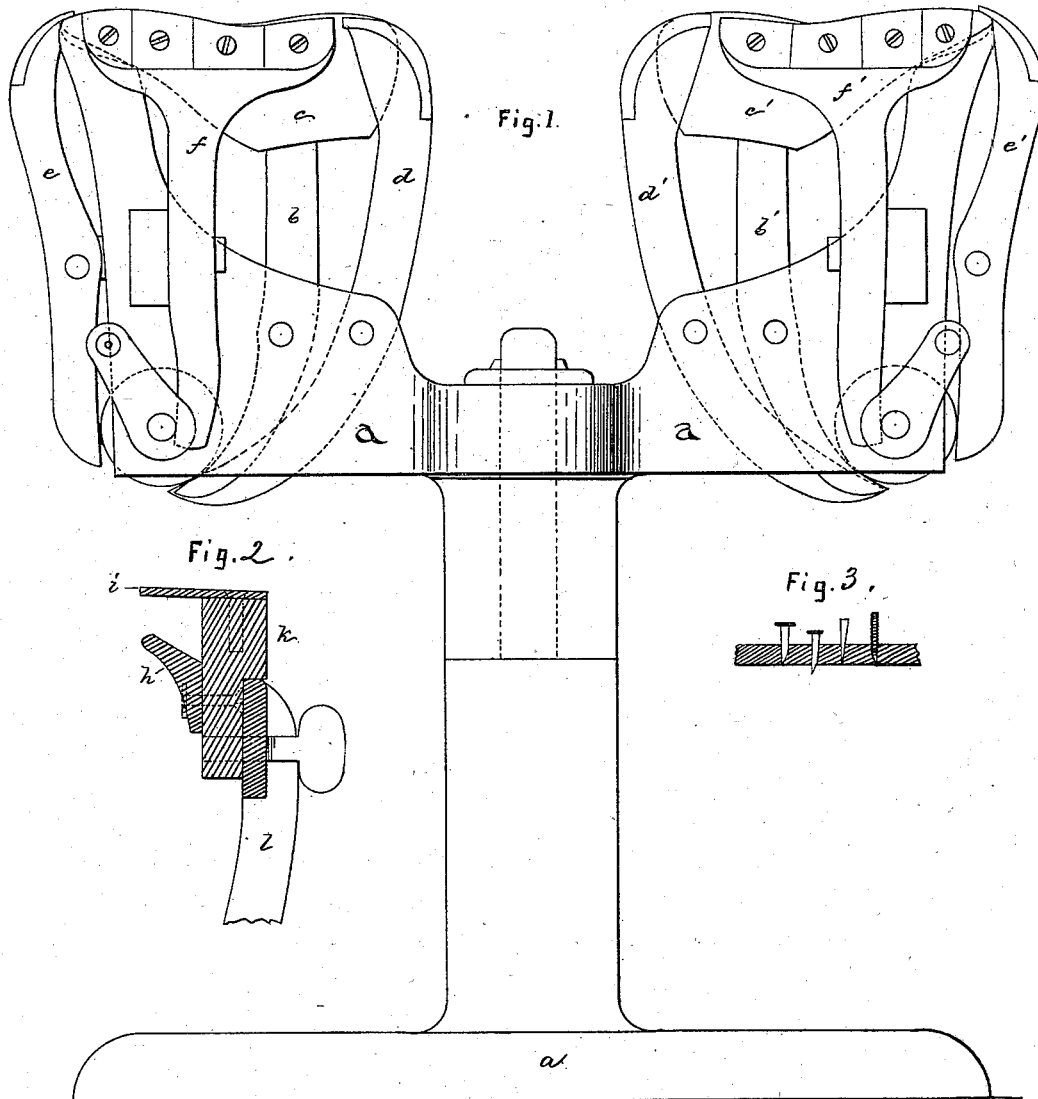

Witnesses.

W. L. Latimer.
W. J. Pratt.

Inventor

George McKay
per *Levi S. Longory* A775

UNITED STATES PATENT OFFICE.

GORDON MCKAY, OF CAMBRIDGE, MASSACHUSETTS.

IMPROVEMENT IN PROCESSES OF MAKING SHOES.

Specification forming part of Letters Patent No. **190,153**, dated May 1, 1877; application filed December 11, 1876.

To all whom it may concern:

Be it known that I, GORDON MCKAY, of Cambridge, in the county of Middlesex and State of Massachusetts, have invented an Improved Process of Making Boots and Shoes, of which the following is a specification:

In the manufacture of boots and shoes, as now practiced, the upper, drawn closely over the inner sole laid upon the bottom of a last, is confined in position by nails or tacks driven into the turned-over edge of the upper and the inner sole. After this lasting operation, so called, which may be done either by hand or by a machine, the outer sole is applied to the lasted shoe, two or more nails confining it in position, and then the outer sole is finally secured, either by pegging, nailing, or sewing.

In the improved process hereinafter claimed the upper is pressed or crowded over the edge of the last by means of a lasting mechanism provided with lasting devices of usual construction, but preferably provided with jaws to bend the upper closely about the last, or the last and inner sole. The shoe, while yet in the lasting-machine, with the edge of the upper held about the last, preferably by the jaws or equivalent lasting devices of the lasting-machine, or otherwise, as hereinafter named, has applied directly to it an outer sole provided or studded with a row of nails or metallic sole-fastenings, preferably headed nails, set back from its edge at the desired distance, and then the nails or metallic fastenings held firmly in, but only partially driven into or through the sole, are driven into the turned-over edge of the upper and into the inner sole, if one is used, the nails being clinched upon an iron or iron-plated last.

In carrying out this invention any ordinary lasting devices may be used, as, for instance, those represented in the lasting-machine made by the McKay Lasting-Machine Association. I prefer to use devices made as jaws provided with gages, against which the edges of the sole may be placed, in order to place the sole in correct position upon the lasted shoe or boot. Such gage and jaws will be made the subject of a separate application.

Two or more of these lasting mechanisms will in practice be mounted upon a movable or rotating frame, so that as one operator at one

position manipulates the lasting devices to draw over and retain the upper in position, another operator can apply a sole to a shoe previously lasted, and yet in the machine, with its upper yet held in proper position either by the lasting devices, or by a very few nails or tacks.

In this way it is obvious that the outer sole can be applied and secured directly to a lasted shoe held upon the lasting-machine by the lasting devices, thereby obviating the use of lasting tacks, nails, or appliances to the extent now commonly and necessarily used to hold the upper and inner sole in position to permit the lasted shoe to be removed from the lasting-machine to a jack to receive the outer sole. The gist of this process, therefore, consists in attaching the outer sole to the upper and inner sole while they are held together by the devices that operated to draw the upper about the last.

It is obvious that the lasting-jaws may be partially opened after they have been fully closed, in order to permit the application of nails quite near the edge of the sole. In such case there may be used, if necessary, a few lasting-tacks to assist in retaining the upper in place, while the jaws are partially withdrawn.

Figure 1 represents one form of lasting device, and illustrates one way in which the invention may be embodied; Fig. 2, a modified form of jaw, it being like the jaw in the McKay lasting-machine; and Fig. 3 a sole with nails.

Fig. 1 shows a bed or platform, *a*, upon which are supported two or more standards, *b b'*, and lasts *c c'*, to hold the uppers to be lasted, and to which soles are to be applied. In this instance the lasting devices consist of heel and toe lasting-jaws *d e* and *d' e'*, and two side jaws *f* or *f'*, one only being shown. The jaws are mounted upon levers operated by suitable cams on shaft *g*. When one operator lasts a shoe by means of the devices *d e f*, another operator applies an outer sole, as described, to the lasted shoe held, say, on the lasting-machine, having the jaws *d' e' f'*.

Instead of the devices shown in Fig. 1 any usual lasting mechanism, with lasting devices adapted to press against and push the upper over the edge of the last, may be employed.

In Fig. 2 the jaw is like that used in the

McKay lasting-machine. The piece of india-rubber *h*, as it is forced against the upper, is compressed, and acts to engage the upper at the side of, and stretch it over, the last, the jaw *i* acting with it to turn the edge of the upper over the inner sole. If the jaw *i* were moved back a little, as before described, to permit the nail to be driven very near the edge of the sole, the edge of the india-rubber piece *h*, compressed as described, would not be released at once from the upper, but would yet hold the upper against the side of the last at or near its edge sufficiently close for the application of the outer sole. The part *k* to which *i* and *h* are secured is made detachable from the lever *l*, to permit the use of jaws of the proper curve for the size of the shoe to be lasted.

In this process it is unnecessary to use tacks or nails, as heretofore, to hold the upper and inner sole together, while the outer sole is being secured, although in some kinds of shoes, where the uppers are very stiff, a few nails may be used, as before mentioned, though the number will be much less than when the last is removed from the lasting-jaws before the sole is permanently fastened to the shoe in the old way.

Instead of driving the nails completely down while the shoe is held by the lasting devices, it is obvious that the nails might be nearly driven, and then completely driven after the shoe was removed from the machine, and the subsequent beating out of the shoe, either by hand or machine, will bring the nails flush with the surface of the sole.

In practice, a broad-faced hammer-like piece of iron, capable of striking a number of nails at one operation is employed; but this is not herein claimed.

The nails or tacks set or studded in the sole

will be but partially driven. Preferably the points of the nails will not be permitted to quite penetrate the sole. Fig. 3 shows a section of a sole studded with tacks.

Lyman R. Blake has invented some different means of driving tacks or nails in this way.

I claim—

1. In the manufacture of boots and shoes, first lasting the upper over the last and inner sole by means of a lasting-machine, and then applying to the lasted shoe while in the lasting-machine a sole set or studded with nails, and then further driving the nails into the outer sole and into the upper and inner sole, substantially as described.

2. In the manufacture of boots and shoes, the process of applying a sole, loaded or set with nails, as described to a lasted shoe having its upper held in position by the lasting devices of a lasting-machine, and then driving the nails held by the outer sole into the upper held by the lasting devices, or into the upper and inner sole, substantially as set forth.

3. In the manufacture of boots and shoes, the described process of attaching the outer sole to the upper and inner sole by a series of nails or metallic fastenings held by, and partially driven into, the outer sole, from which they are subsequently driven into the upper and inner sole, while the lasting devices hold the upper about the last and inner sole, substantially as described.

In testimony whereof I have signed my name to this specification in the presence of two subscribing witnesses.

GORDON MCKAY.

Witnesses:

G. W. GREGORY,
S. B. KIDDER.