

J. ZANE.  
WATER-CLOSET.

No. 190,178.

Patented May 1, 1877.

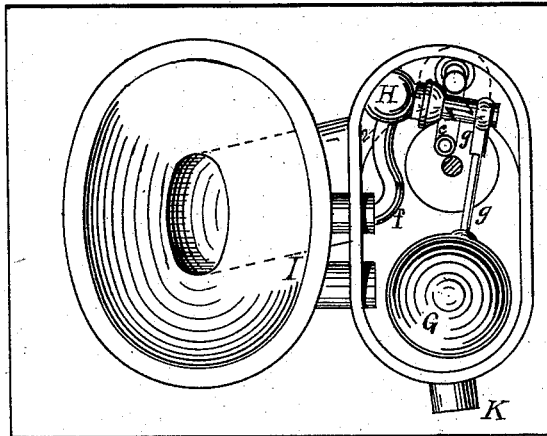

Fig. 1.

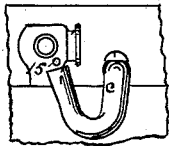

Fig. 4.

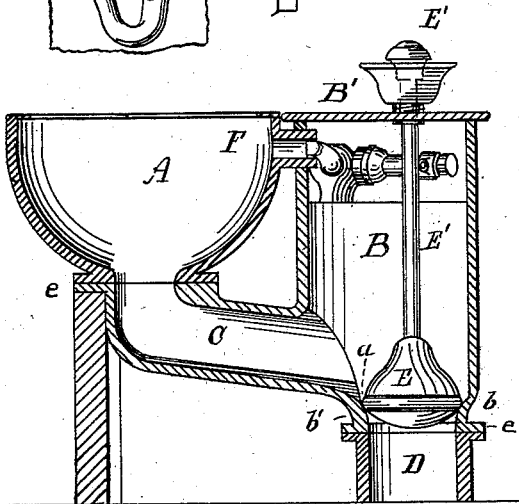

Fig. 2.

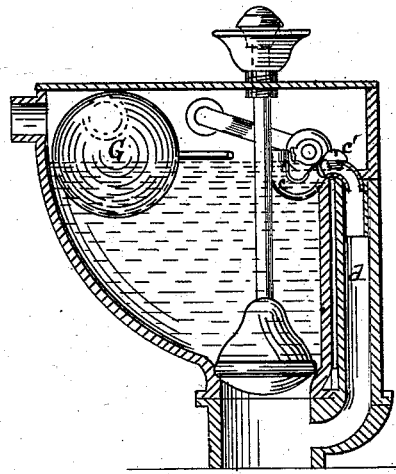

Fig. 3.

WITNESSES

*F. F. Raymond & Co.*  
*Francis Roach*

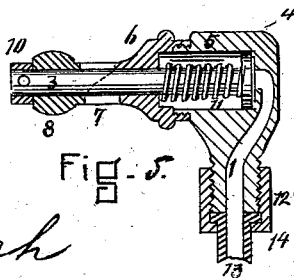

Fig. 5.

INVENTOR

*Joseph Zane*

J. ZANE.  
WATER-CLOSET.

No. 190,178.

Patented May 1, 1877.

*Fig. 6*

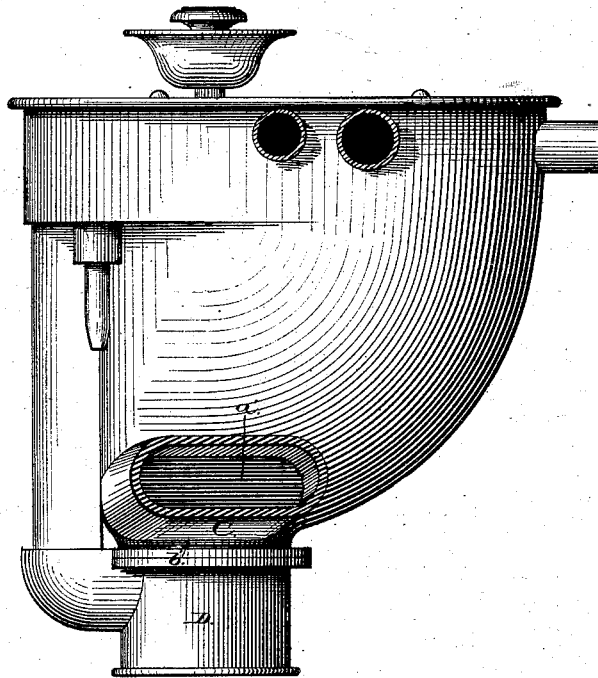

*Attest:*

*H. L. Raymond*  
*Francis Roach*

*Inventor:*

*Joseph Zane*

# UNITED STATES PATENT OFFICE.

JOSEPH ZANE, OF BOSTON, MASSACHUSETTS, ASSIGNOR OF ONE-HALF HIS  
RIGHT TO FRANCIS ROACH, OF SAME PLACE.

## IMPROVEMENT IN WATER-CLOSETS.

Specification forming part of Letters Patent No. **190,178**, dated May 1, 1877; application filed  
February 17, 1877.

### *To all whom it may concern:*

Be it known that I, JOSEPH ZANE, of Boston, in the county of Suffolk and State of Massachusetts, have invented an Improvement in Water-Closets, of which the following is a specification:

This invention has for its object the following purposes: first, the perfect flushing of the bowl and outlet pipe at every discharge of their contents; second, in preventing the escape of sewage-gas and unpleasant odors from the bowl; third, in so constructing my improvements that they are applicable to any of the bowls commonly in use.

These results I obtain by the following described mechanism and arrangement of parts, relative to each other.

Reference is made to the accompanying drawing, forming a part of this specification, in explaining the same, in which—

Figure 1 is a plan of the water-closet; Fig. 2 is a vertical section on the line *x x*, Fig. 1, and Fig. 3 is a vertical section on the line *y y*, Fig. 1. Figs. 4 and 5 are detail views. Fig. 6 is a cross-section, showing the oval shape of the outlet-pipe.

Arranged immediately next to, and preferably on the right side of, the bowl A, is the reservoir B; and the outlet C—the cross-section of which presents an oval or somewhat elliptical form of less vertical than horizontal measurement, (represented in Fig. 6 at *a'*), which thus enables this closet to be placed over the stench-trap set for a pan-closet of usual construction, and to have the usual bowl of such a closet set upon the flanges *e* of the said oval pipe without raising the seat unduly, and without making the outlet C of too little inclination to be practical, as in some previous contrivances—is inclined from the bottom of the bowl to the base of the reservoir, connects the two parts, and conveys the contents of the bowl to the waste-pipe D.

A plunger, E, with the handle E<sup>1</sup> and packing *a*, closes the waste-pipe D by the contact of the packing with a valve-seat, *b*. The reservoir is covered by plate B.

Water enters the bowl through supply-pipe F, and its volume is regulated by the height of the water in the reservoir, which, through the weighted ball G and arm *g*, operate a cock, H, whose construction will be hereinafter explained.

A small stench-trap, *c*, provided at its upper bend with a hole, *c'*, with pipe *d'*, which communicates from or near the top of the reservoir, to the waste-pipe below the valve-seat, together serve in providing an overflow or water-escape from the reservoir.

The bowl is also provided with the entrance I opening into the reservoir a trifle below the opening of the supply-pipe, and the hole K upon the side of the reservoir, near its top, is designed to open into a pipe leading to the hot flue of a chimney, or some other ventilator.

The cock or faucet which regulates the feeding of the water is arranged inside the reservoir, and consists of an induction-way, 1, an eduction-way, 2, a spindle, 3, a valve, 4. The casing of the cock is composed of the chamber 5, the cap 6, which screws onto the chamber as shown, and is provided at its other end with cams 7, a key, 8, with cams conversely arranged to those on cap 6, and an arm, 9, projecting from the key and provided with a hole for the reception of the arm *g*, which is fastened therein by a set-screw. The key is held on the spindle by the washer and pin 10, or any other suitable contrivance. Inside the chamber, and surrounding the spindle, is the spring 11, one end of which bears against the end of the cap and the other upon the valve, which constantly acts to force the valve to its seat. The valve has a packing arranged over and somewhat larger than the induction-way inserted on its face, and the valve-seat is formed by the end of the chamber.

One end of chamber 5 projects outside the reservoir, and is provided with a screw-thread, upon which cap 12 is screwed. This cap not only serves to hold the nipple 13 against the end of the joint by means of the flange 14, but it also holds the cock in position on the inside of the reservoir by being screwed tightly against the wall of the reservoir outside the same.

Hole 15 is formed in chamber 5 or in the eduction-way 2, immediately over and opening into the top of stench-trap *c*. It is very small in size, and is designed to permit the escape of a small stream of water into the stench-trap every time the cock is opened, so that the water-seal in the trap may not be broken by evaporation. Fig. 4 clearly shows this construction.

It is substantially a self-closing cock, which, if the weighted ball were detached, would close against the pressure of the water.

It is designed to make the reservoir and the outlet from the bottom of the basin in one casting, or, if desired, of sheet metal, and of a shape that will enable my attachment to be fitted to most of the bowls now in use, and for this purpose I form the flanges *e* on the same.

The operation of my invention is as follows: The water is first fed, under the usual shield, to obtain a surface-washing into the bowl, from which it flows into the reservoir, and the bowl and reservoir are filled to the top of the overflow. Upon the lifting of the plunger the contents of the bowl and reservoir are discharged through the waste-pipe *D*, and by the lowering of the water in the reservoir the cock is opened by the descent of the ball, and a fresh volume of water is let into the bowl, which completely flushes it. Meanwhile all odors and sewage-gas is drawn from the bowl through the opening *K* into the reservoir by the partial vacuum formed by the rapid lowering of the water in the reservoir, and escapes from the reservoir through the opening into the chimney-flue or ventilator.

The cock is so adjusted as to be closed when the water has reached the level of the top of the overflow *e*, a sufficient amount escaping from hole *l* to keep the water-seal in the overflow from being broken by evaporation at every opening of the cock.

It will be observed that the sewage-gas cannot escape through the overflow because of the water-seal, and it will be seen that provision is made for cleaning the trap easily, by means of the hole *c'*, into which a screw is fitted.

The advantages of my invention consist in the complete flushing of the bowl and the removal of its contents to the waste-pipe, in the manner described, and the providing of an escape for sewage-gas from the bowl and reservoir.

The ball-cock (shown in section at Fig. 4, and in elevation and plan in the other figures) has a peculiarity of action, caused by its peculiarity of construction.

The ordinary compression ball-cock depends for its action upon a fine adjustment between the position of the bulb and its relation to the screw in which the stem works and the seat of the valve, and the rise of the water in the reservoir by lifting the ball screws the valve directly to the seat, and often the valve-seats are injured by a failure of this adjustment.

In the cock shown, the spring *ll* compresses the valve to the seat by a constant power, which can never exceed, but must always be less than, the pressure of the spring when the water is not on, and the work of the ball is to open the valve only by compressing the spring.

This requires a heavier ball than the usual one, with less power of flotation, and is therefore short-handled, and submerged below its center.

When the valve is on its seat, the flotation power of the ball is exerted not to screw the valve to the seat, but to screw the cap of the cock on, and this whole combination makes a novelty in ball-cocks specially useful in this apparatus, because they decrease the requisite size of reservoir *B* by being short-handled, deeply immersed, and quick-moving, and very sensitive, and thus prevent waste of water, the immersion lessening the height and the shortness of handle the length of the reservoir.

When the soil-pipe *D* is trapped below the reservoir the stench-trap *c* may be dispensed with, and it is made simply as a crooked pipe dropping into the overflow *d*.

Having thus fully described my invention, I claim and desire to secure by Letters Patent of the United States—

1. In a reservoir water-closet, the combination of reservoir *B* with the bowl *A*, by means of the inclined outlet *C* of less vertical than horizontal measure, and fitted and formed to receive the bowl *A*, substantially as described.

2. The described means of ventilating the reservoir *B* and bowl *A* by the communication *I* between the reservoir and bowl, and the communication *K* from the reservoir to a ventilating-flue, substantially as described.

3. The spring compression-cock herein described, in which the valve is compressed to the seat against the flow of the water solely by an independent spring, and the spring-pressure is relieved and the valve raised by single-acting screw-cams rotated against the pressure of the spring by a short-handled ball deeply immersed, and with very slight power of flotation.

4. In a reservoir water-closet, the combination of the covered reservoir *B*, automatically supplied with water discharged into the bowl, and regulated in quantity by mechanism in the reservoir, and having a gas-escape, *I*, provided between the reservoir and bowl, with a soil-pipe, *D*, whose capacity for discharge is sufficiently in excess of the water-supply to create a draft through said communication *I* during the discharge of bowl, substantially as and for the purpose described.

5. The combination of the stench-trap *c*, with the cock *h*, provided with a hole for the escape of water into the top of the stench-trap, when the cock is open, whereby the water-seal in the stench-trap is prevented from being broken by evaporation, substantially as and for the purpose described.

JOSEPH ZANE.

Witnesses:

F. F. RAYMOND, 2d,  
FRANCIS ROACH.