

A. BECK.  
QUILTING-MACHINE.

No. 190,184.

Patented May 1, 1877.

Fig. 1.

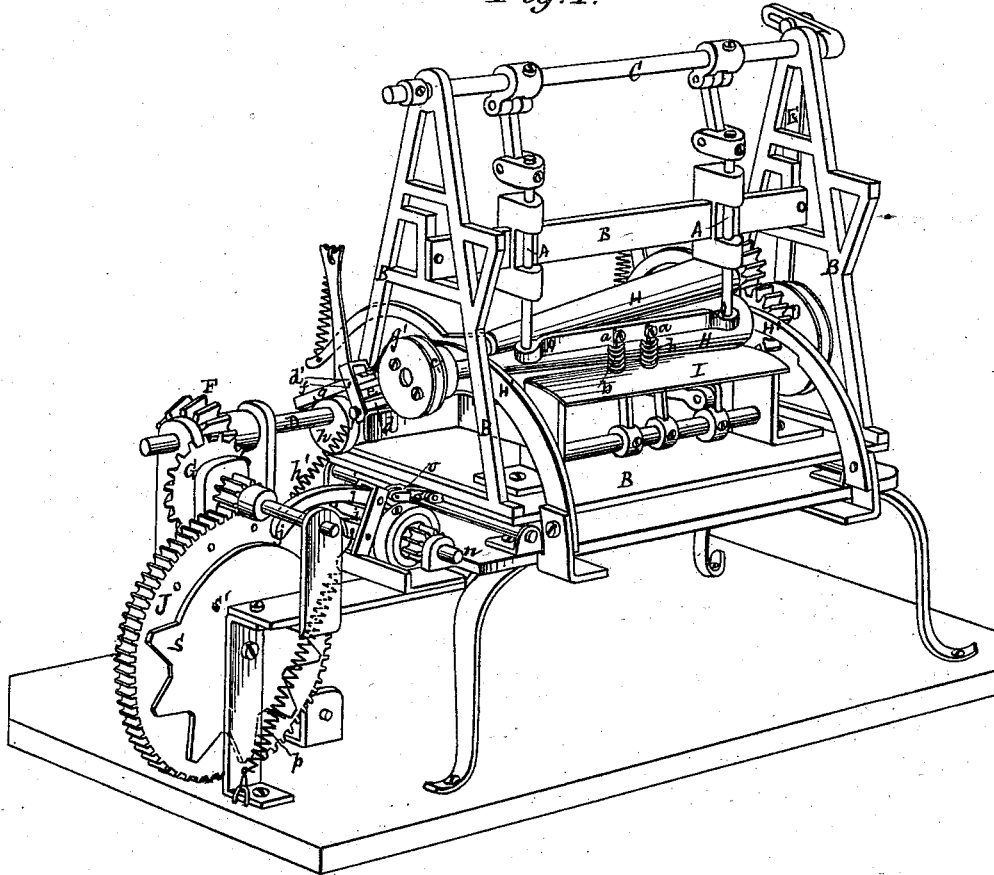

Witnesses:

Evell A. Dick  
D. T. Fowl.

Inventor:

August Beck by  
Atty. Pollock & Bailey.

A. BECK.  
QUILTING-MACHINE.

No. 190,184.

Patented May 1, 1877.

Fig. 2.

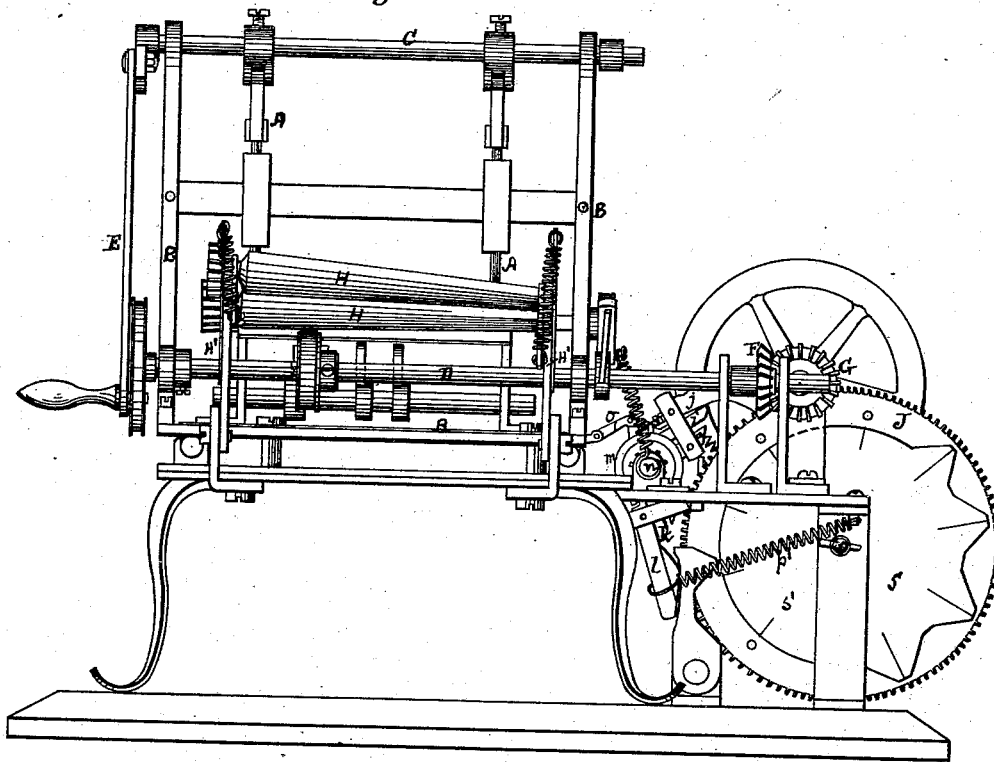

Fig. 3.

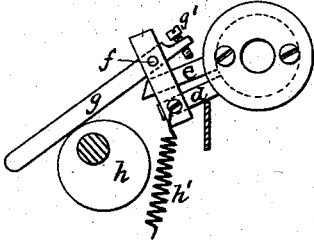
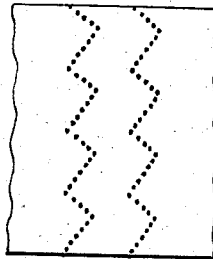

Fig. 4.



Witnesses:  
Evelle Dick  
D. F. Low

Inventor:  
August Beck by  
Atty Pollock Daily

# UNITED STATES PATENT OFFICE.

AUGUST BECK, OF NEW YORK, N. Y., ASSIGNOR TO LOUIS DRYFOOS AND JOSEPH DRYFOOS, OF SAME PLACE.

## IMPROVEMENT IN QUILTING-MACHINES.

Specification forming part of Letters Patent No. **190,184**, dated May 1, 1877; application filed February 27, 1877.

*To all whom it may concern:*

Be it known that I, AUGUST BECK, of the city, county, and State of New York, have invented certain new and useful Improvements in Quilting-Machines, of which the following is a specification:

The machine to which my invention relates is a sewing-machine intended to be used for quilting fabrics. It may be used, however, for sewing ornamental patterns of various kinds.

My invention consists of certain improvements on the quilting-machine described and shown in my Letters Patent No. 159,884, dated February 16, 1875, these improvements having reference to the presser-foot, the feed, and the mechanism for laterally reciprocating the sewing-frame. They will be explained by reference to the accompanying drawing, in which—

Figure 1 is a perspective view of the machine. Fig. 2 is a rear elevation of the same. Fig. 3 is a side elevation, on an enlarged scale, of the mechanism through the intermediary of which the feed is effected. Fig. 4 is a pattern of the stitching made by the machine.

I shall give but a general and brief description of such parts of the machine as are not immediately related to my improvements. The general organization does not materially differ from that of the machine described in my above-recited Letters Patent.

In the use of my patented machine difficulty was experienced in the use of the presser-feet, which, under the arrangement described in the patent, were apt to rub and drag on the cloth, which was, therefore, at times caused to follow the reciprocating movement of the sewing-frame. The arrangement itself was, moreover, somewhat complicated and cumbersome.

My present improvement consists in combining, with each and every needle bar or holder *a*, an annular vertically-yielding presser-foot, *b*, attached to, and moving up and down with, the bar, and surrounding the needle. The presser-feet thus press the goods only during the formation of the stitches. They rise with the needles, and their pressure

on the goods is entirely taken off when the needles are out of the cloth.

They are made vertically yielding by being in part composed of spirally-coiled wire springs, as shown.

The needle-holding frame (marked A) moves up and down in guides in the laterally-reciprocating sewing-frame B, this up-and-down movement being imparted from a rock-shaft, C, which is operated by a crank and driving-shaft, D, through the medium of a connecting-rod, E, jointed to a slotted arm on shaft C, in which arm its joint-pin is adjustable to or from the axis of shaft C, in order to regulate the length of needle-stroke. The driving-shaft D is rotated by gearing F G, the gear-wheel F having fixed bearings, and being connected with the shaft D by a spline-and-groove connection, which permits the shaft to laterally reciprocate with the sewing-frame independently of the driving-gear.

In my patented machine the regular forward feed of the goods was effected by feed-rollers intermittently rotated by means of a pawl and ratchet. No adequate provision was there made for a change of feed.

I now use a different mechanism for actuating the feed-rolls, and so organize it that the length of feed may be varied at pleasure.

The feed-rolls are shown at H. They are intended, in this instance, to feed the conical bodies of skirts or skirt-borders, and are, therefore, for this purpose, made conical. The cloth to be sewed passes over the cloth-plate I, under and back of the lower roll; thence up between the two rolls, and to the front of the upper roll, over which it finally passes. The rolls are made conical only for the purpose above mentioned. To feed straight goods they are made cylindrical. They do not move with the sewing-frame. They have no movement of lateral reciprocation, but revolve in bearings formed in a stationary frame, H'. They act intermittently, resting during the formation of the stitch, and feeding the goods when the needles are out of the cloth. The intermittent movement of rotation is produced as follows:

The lower roll is the one that is positively acted on. The other roll has movable boxes acted on by springs, which cause it to bear with a yielding pressure on the lower roll, the two rolls being geared together, as shown.

The shaft or journal of the lower roll is, at one end, prolonged to extend beyond its bearing, and on this prolonged end is mounted a hub, the periphery of which is encircled by a spring ring-like clasp, *c*, which is not a continuous ring, but has separate ends, one of which, *d*, carries a yoke, *d'*. The other end, *e*, directly above the end *d*, is free, and normally is somewhat separated from the other. Pivoted at *f* in the yoke *d* is a lever, *g*, whose shorter arm overhangs the end *e*, and whose longer arm is in contact with a cam, tappet, or eccentric, *h*, on the driving-shaft, said part *h* being of a width sufficient to allow it to reciprocate with the sewing-frame without quitting the lever.

When the longer arm of the lever is raised by the cam, its shorter arm bears on the end *e* of the spring-clasp, and first forces it down toward the other end, and so causes the clasp to clutch the hub. The continued movement of the lever now causes the hub to make a movement of partial rotation, thus operating the feed-roll. The extent of movement of the roll is determined by the amount of lost motion of the lever, and this lost motion is regulated by means of a screw, *g'*, in the shorter arm of the lever, which may be caused to approach the end *e* of the clasp more or less, as required.

I thus, in effect, have a friction-clutch which is caused to engage and operate the feed by means of a vibratory lever, which is caused to act on the clutch sooner or later in its stroke, according to the length of stitch required. The lever is held down to the eccentric *h* by a spring, *h'*.

The same kind of mechanism is employed to give movement to the laterally-reciprocating sewing-frame. In this case, however, as seen in the drawing, the mechanism is duplicated, one friction-clutch, *i*, and lever *j* being required to move the frame in one direction, and one friction-clutch, *k*, and lever *l* being required to move the frame in the other direction. The mechanisms are mounted one on one side, and the other on the other side, of a central flange, *m*, on a shaft, *n*, which is rocked back and forth by the action of the clutches, and is connected with the sewing-frame by a rod, *o*, jointed at one end to an arm projecting from the sewing-frame, and at the other end to a radial arm projecting from the shaft *n*, or from the flange *m* thereon.

The levers *j* and *l* are held by springs *p* *p'* against the pattern-cams, by which they, respectively, are acted on, and this brings me to the last portion of my improvements, which relates to the pattern mechanism, or mechanism

for giving to the sewing-frame the lateral movement required for the particular pattern to be made.

In my patented machine I use for this purpose a peripherally cam-grooved pattern-wheel. This wheel is required to be changed not only for each regular feed—*i. e.*, for varying length of stitches, but also for every figure or pattern. To remedy inconveniences arising from this plan I have now adopted a permanent wheel, *J*, gearing with the driving mechanism, and carrying on its opposite faces the cams *s*, which operate the levers of the friction-clutches. These cams are removable from the wheel, and may be replaced by others, so that with the same wheel any number of pattern-cams can be interchangeably used. The cam-points *s* may be in one piece with the central disk *S'*, or they may be made separate from the disk, and attached independently of one another to the wheel. The wheel is of a size to make one element of the design or pattern, so that at each revolution of the wheel one element of the design will be completed. For instance, the cams shown in the drawing will make the zigzag pattern shown in Fig. 4, and that pattern is composed of a number of elements, each of which consists of up-and-down lines in **V** form. While the series of cams on one side of the wheel act on one lever, the other lever is opposite the open space on the cam-disk on the other side of the wheel. Thus the one set of cams, acting on one lever by a series of intermittent-impulses, draws the sewing-frame in one direction. Those cams then become inactive, and the opposite set commences to act on the other lever, causing the frame to move in a similar manner in the other direction, thus, in conjunction with the regular forward feed, causing a pattern to be produced like that shown in Fig. 4.

I have described only so much of the machine as required to illustrate my improvements. The stitch-forming mechanisms, one for each needle, may be of any approved pattern, embracing tension, take-up, spool-holder, shuttle or hook for the under thread, &c.

Having described my improvements, what I claim, and desire to secure by Letters Patent, is—

1. The combination, substantially as set forth, with a series of vertically-reciprocating needles, of a like number of vertically-yielding and elastic annular presser-feet, one for each needle, each presser-foot surrounding its needle, and attached to and moving with the needle bars or holder, and rising from the cloth-plate when the feed takes place.

2. The combination of the laterally-reciprocating sewing-frame and independent forward feed with a series of needles carried by said sewing-frame, and a like number of vertically-yielding annular presser-feet, one for each

needle, each presser-foot surrounding its needle, and attached to and moving with the needle bar or holder, as shown and set forth.

3. The described mechanism for operating the feed, consisting of a friction-clutch clasp- ing the feed-shaft, in combination with a vi- bratory pivoted lever, supported on one end of the clutch, and having one of its arms over- hanging, but not attached to, the other and free end of the clutch, substantially as set forth, so that the movement of said lever shall cause the clutch first to close upon the shaft, and then to rotate the same, as set forth, and this I claim whether the said mechanism be used to operate the forward or the lateral feed.

4. The combination of the friction-clutch, the feed-shaft embraced by the same, and the vibratory lever, provided at that end which acts on the clutch with means of adjustment, whereby the lost motion of the lever may be increased or decreased at pleasure, to regu- late the length of the feed.

5. The combination, with the sewing-frame, of the pattern-wheel and removable pattern-

cams, one set on each face of the wheel, the one set designed to move the sewing-frame in one direction, the other set in the other direc- tion, each set acting alternately on the frame, and both being removable to allow different sets of pattern-cams to be interchangeably used on the same wheel.

6. The pattern-wheel, with removable pat- tern-cams, one set on each face of the wheel, in combination with friction-clutches and their operating-levers, one set for each set of pat- tern-cams, and a rock-shaft, on which said clutches are mounted, connected with and imparting a laterally-reciprocating movement to the sewing-frame, substantially as herein shown and set forth.

In testimony that I claim the foregoing as my own I affix my signature in presence of two witnesses.

AUGUST BECK.

Witnesses:

W. S. DEHART,  
GEORGE F. LANGBEIN.

2,400