

W. A. CLARK.
HORSE DETACHER.

No. 190,197.

Patented May 1, 1877.

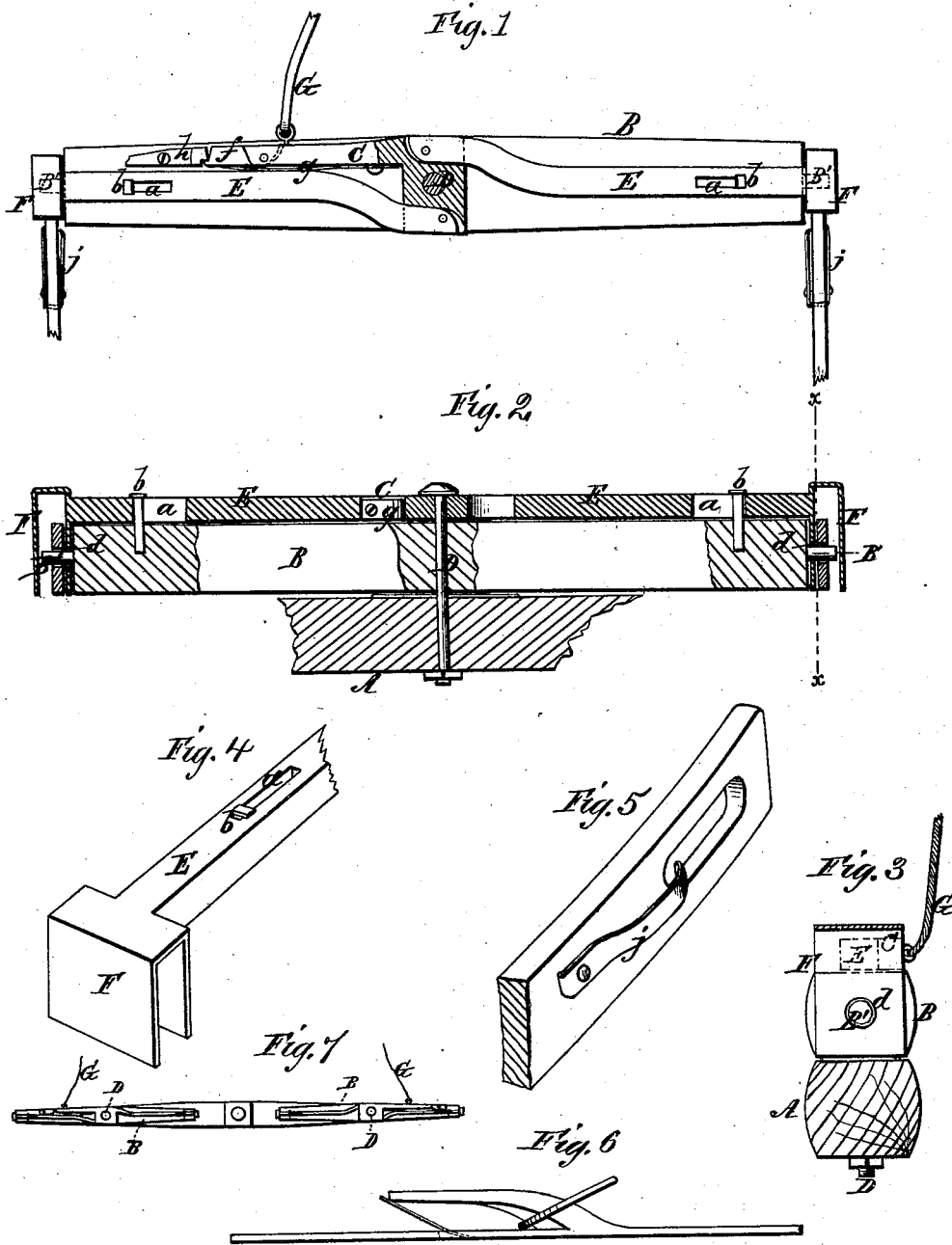

Witnesses.
James Martin Jr.
J. P. Theodore Lang

Inventor.
William A. Clark.
By
Mason, Fenwick & Lawrence.

UNITED STATES PATENT OFFICE.

WILLIAM A. CLARK, OF JACKSONVILLE, GEORGIA.

IMPROVEMENT IN HORSE-DETAACHERS.

Specification forming part of Letters Patent No. **190,197**, dated May 1, 1877; application filed February 16, 1877.

To all whom it may concern:

Be it known that I, WILLIAM A. CLARK, of Jacksonville, in the county of Telfair and State of Georgia, have invented a new and useful Improvement in Horse-Detachers for Vehicles; and I do hereby declare that the following is a full, clear, and exact description of the same, reference being had to the accompanying drawings, forming part of this specification, in which—

Figure 1 is a top view of a single-tree of a vehicle with my invention applied to it. Fig. 2 is a vertical central section, showing the single-tree and supporting-bar of a vehicle with my invention applied to it. Fig. 3 is a vertical cross-section in the line *xx* of Fig. 2. Fig. 4 is a perspective view of a portion of one of the harness-trace-detaching levers. Fig. 5 is a perspective view of a portion of one of the harness-traces. Fig. 6 is a side view of one of the fastenings for harness holdback-strap. Fig. 7 is a top view of a double-tree with the invention applied to it.

The object of my invention is to provide a simple mechanical appliance for vehicles, whereby one or two horses may, at will, be detached from a carriage or vehicle by the driver, and thus serious damage prevented at times when the horse or horses become unmanageable.

The nature of my invention consists in certain constructions, combinations, and arrangements of parts, as hereinafter described and specifically claimed.

In the accompanying drawings, A represents the cross-bar of a vehicle, to which the shafts are attached. B is the single-tree, formed with pins B' on its ends to receive and support the harness-traces. C is an L-shaped lever fastened to the single-tree and cross-bar by a bolt, D, which forms the pivot for the single-tree and for the lever. E E are arms pivoted to the short end of the elbow-lever on opposite sides of its fulcrum-bolt D. These arms are slotted at *a a*, and through these slots guide and stop or gage pins *b b* are passed into the single-tree. These pins prevent the arms and their cuffs moving too far while unhitching a horse. F F are U-shaped cuffs or trace-strippers formed on the ends of the arms. Through the inner sides of the cuffs

the holes *d* are formed for the passage through them of the pins B' of the single-tree. The long arm of the lever C extends along toward one end of the single-tree, while its short arm extends across its central portion. To the extremity of the long arm a catch, *f*, is pivoted, and this catch is acted upon by a spring, *g*, and caused to latch into a latching-piece, *h*, attached to the single-tree. G is a strap, made of a material which allows it to yield to a limited extent. This strap is fastened to the lever and carried back to the driver's seat and fastened in a proper manner. When the single-tree vibrates, the strap permits the same without releasing the catch, but when the elasticity of the strap is exhausted by a pull with the hands the catch is operated and the lever operates the arms and releases the traces from the pins.

In connection with the devices described a spring or springs, *j*, are fastened to the outside of one or both of the traces near their attaching slotted ends, and the slots of the traces are made oblong. The spring or springs *j* serve to hold one of the traces between the sides of the cuff in proper position for passing its slotted end over a pin of the single-tree, while the other end is being adjusted to the same position, and the oblong slots in the traces permit the springs to clear the cuff after the traces are properly fastened. To attach the traces, the L-shaped lever is moved backward. This causes the outer side of the cuffs to move out from the ends of the pins of the single-tree. The trace with spring fastened to it is inserted between the sides of the cuff with its slot in line with the pin. The other trace is next adjusted in same manner, and the lever moved forward far enough to become latched, which operation causes the cuffs to force the traces upon the pins, where they are held by the outer sides of the cuffs, as illustrated in Fig. 2.

To release the traces the lever has only to be again pulled back by the strap.

In order to have the holdback-strap of the harness detachable with the traces a holdback-hook with spring to close its opening is employed on each of the shafts, as shown in Fig. 6.

If it is desired to use the invention in con-

nection with double harness or two-horse carriages, two single-trees, such as the one represented in Fig. 1, are applied to the double-tree in the manner shown in Fig. 7, and the breast-chains will be allowed to slip out from a hook fastened on the end of tongue, the hook being similar to the one used with the breeching or holdback strap.

My invention is applicable to different kinds of wheeled vehicles and to agricultural machines—such as plows, planters, cultivators, horse-powers, and reapers—and it will be of great benefit in cases where the safety of the driver and others and protection of machinery depends upon the release of the horse or horses from the carriage or machine.

What I claim as new is—

1. In combination with the pins *B'* on the ends of the single-tree, the arms *E E*, having the cuffs *F F*, and slots *a*, guided by pins *b* on the single-tree, the said arms being constructed to move horizontally with the sin-

gle-tree when operated by the lever *C*, and caused to remain horizontal with the single-tree when latched, substantially as described.

2. The combination of the strap *G*, operated as specified, spring-catch *f*, latching-piece *h*, lever-arms *E E*, cuffs *F F*, and single-tree, substantially as and for the purpose described.

3. The combination of the trace provided with a spring, *j*, and oblong slot, and the *U*-shaped cuffs *F* of the arms *E*, substantially as described.

4. The angular lever *C*, having a hinged latching portion on its long arm, substantially as and for the purpose described.

Witness my hand in the matter of my application for a patent for an improved horse-detacher for vehicles this 9th day of February, 1877.

WILLIAM A. CLARK.

Witnesses:

J. D. WYNNE,

D. H. McINTOSH.