

J. A. OSENBRÜCK.
RAILWAY WHEEL.

3 Sheets—Sheet 1.

No. 190,246.

Patented May 1, 1877.

FIG. 3.

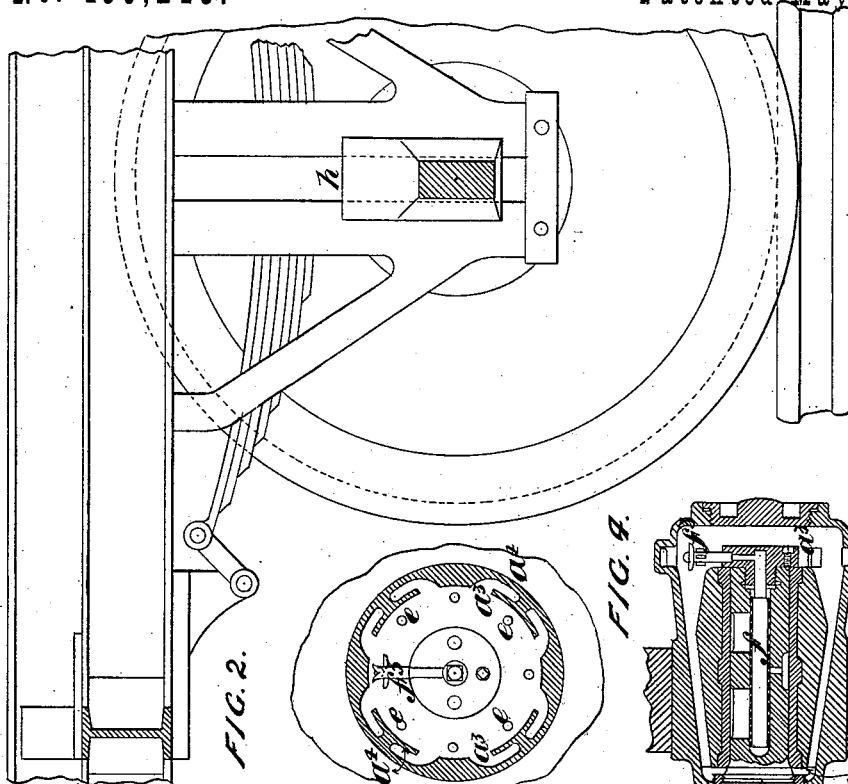

FIG. 2.

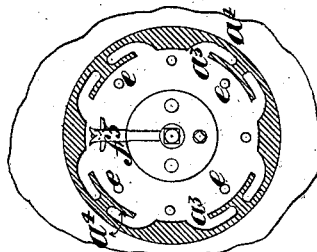

FIG. 4.

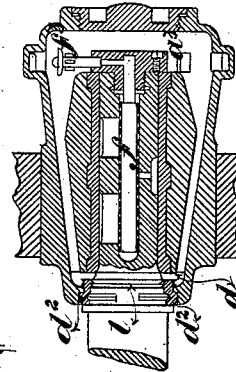

FIG. 1.

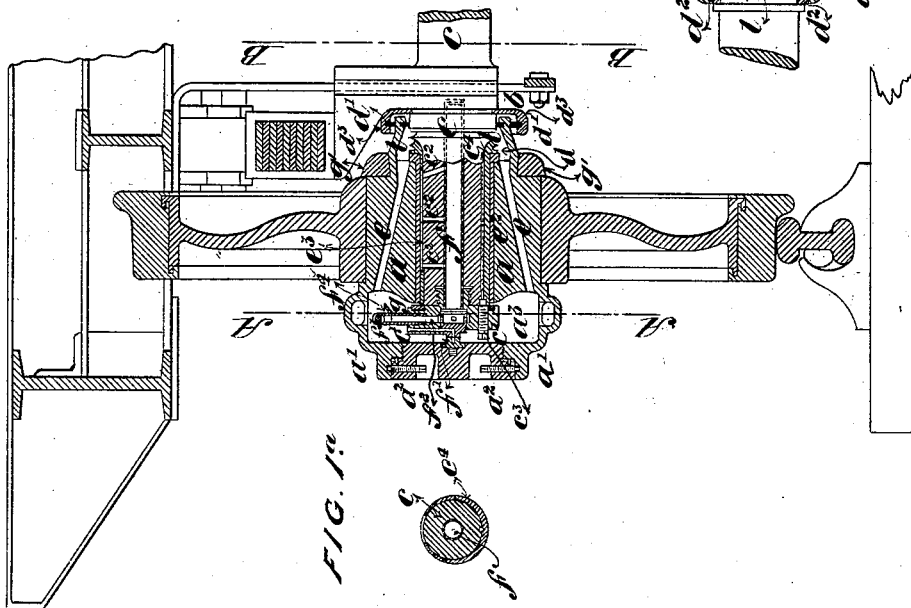

FIG. 1st

Witnesses

Chas. Smith
Harold Ferrill.

Inventor.

J. A. Osenbrück.
per Lemuel W. Ferrill atty.

J. A. OSENBRÜCK.
RAILWAY WHEEL.

3 Sheets—Sheet 2.

No. 190,246.

Patented May 1, 1877.

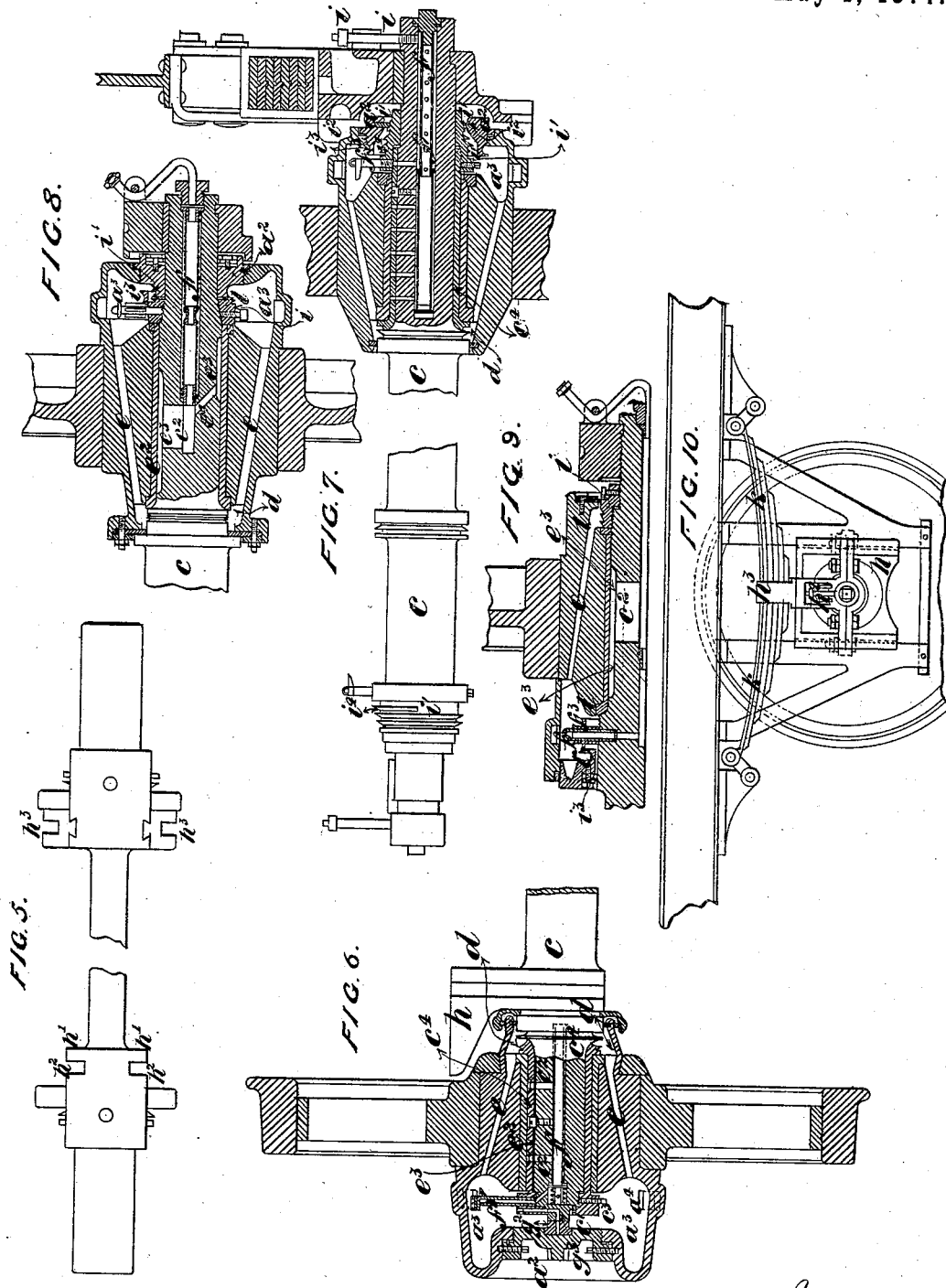

Witnesses

Charles Smith
Harold Ferrell

Inventor

J. A. Osenbrück
per Lemuel W. Ferrell atty.

J. A. OSENBRÜCK.
RAILWAY WHEEL.

3 Sheets—Sheet 3.

No. 190,246.

Patented May 1, 1877.

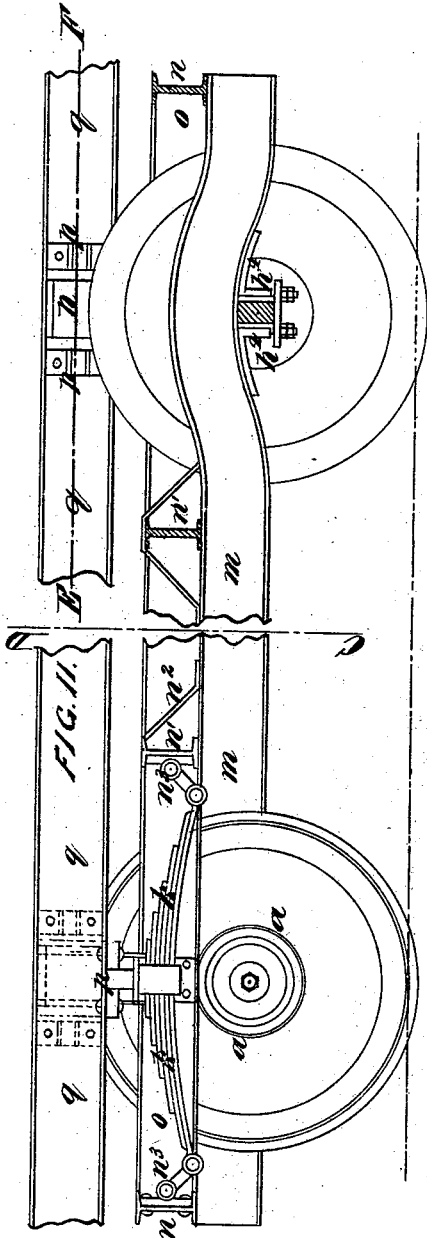

FIG. 10.

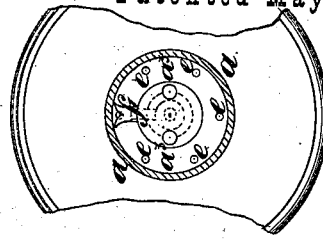

FIG. 14.

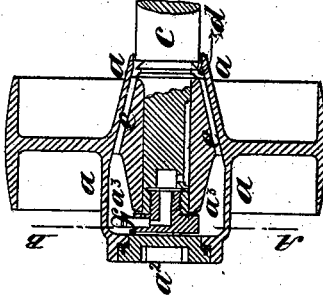

FIG. 12.

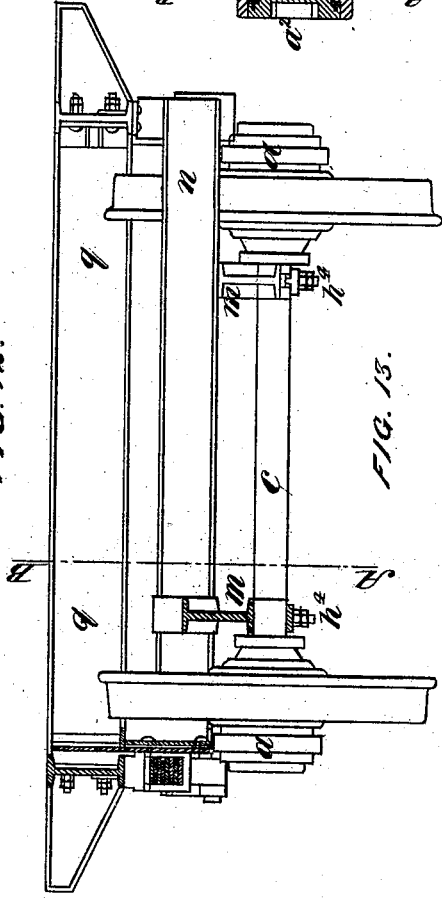
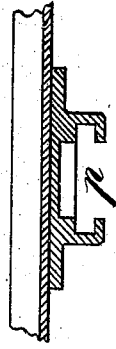

FIG. 15.



Witnesses
Charles Smith
Harold Serrell

Inventor
J. A. Osenbrück
per Lemuel W. Serrell atty.

UNITED STATES PATENT OFFICE

JOHANNES A. OSENBRÜCK, OF HEMELINGEN, NEAR BREMEN, GERMAN EMPIRE.

IMPROVEMENT IN RAILWAY-WHEELS.

Specification forming part of Letters Patent No. 190,246, dated May 1, 1877; application filed December 2, 1876.

To all whom it may concern:

Be it known that I, JOHANNES AUGUST OSENBRÜCK, of Hemelingen, near Bremen, in the German Empire, have invented new and useful Improvements in Railway-Wheels and Axles, which improvements are fully set forth in the following specification, reference being had to the accompanying drawings.

The principal objects of this invention are as follows: To overcome the evil effects arising from the friction which takes place at present between railway-car wheels and rails, especially in passing round curves; to improve the means of lubricating the bearing or journal surfaces of such wheels and their axles, and to diminish the wear and tear in such journals; to reduce vibration and the violent twisting-strain to which such axles as at present constructed are subjected; and to obtain by these means a steadier and easier motion of the carriage, so that as a result a train shall require less draft-power and be run at a less expense for fuel, oil, and repairs.

According to this invention the axles are fast, and the wheels revolve loose thereon, all as hereinafter described.

The improvements refer to the construction of the wheel-bosses, the axles, and especially the journal parts of same, and the bearing-brackets, and other parts of the under part of the carriage, by which parts the axles are carried.

I will first describe this invention with reference to loose railway-wheels placed outside the supporting-springs and horn-plates.

Figure 1 is a vertical section of a railway-wheel and axle, and parts connected therewith. Fig. 2 is a transverse section at line A A, Fig. 1. Fig. 3 is a transverse section at line B B, Fig. 1, viewed from between the wheels.

a is the wheel-boss, which in this case is forced into the wheel by hydraulic pressure, the wrought-iron ring g^1 being then shrunk on. The nave is in front surrounded by a concentric mantle, a^1 , closed oil-tight by an end cover, a^2 . The space a^3 between this mantle a^1 and the front part of the boss a forms what may be termed the oil-supply or centrifugal chamber. At the back or inner side

of the wheel-boss a there is another concentric but smaller mantle, b , closed oil-tight by a leather or other suitable packing-ring forming joint with the axle c . The space d within forms the oil-collecting chamber. The oil-supply chamber a^3 and the oil-collecting chamber d are united by one or more passages, e , slanting from the latter down to the former. On Fig. 2 are shown seven such passages. The collecting-chamber d is, by preference, made sloping inside, as shown, increasing in diameter toward the opposite side of the wheel and the slope of the connecting passage or passages e to the front or centrifugal chamber. a^3 is, by preference, made less than that of the oil-collecting chamber d . The axle is formed with a central chamber, f , which may be fitted or filled, as here shown, with a filter or filtering appliance. The central chamber f in the axle communicates by the passage f^2 with a catch-tube, f^3 , fastened to the axle c itself, or, as here shown, to a ring or disk, c^1 , screwed onto the axle c . This tube f^3 reaches nearly to the greatest inside diameter of the supply-chamber a^3 , being, by preference, placed in a vertical position, as shown. Its mouth is splayed in both directions of revolution of the wheel. It has also a catch-basin, f^4 , beneath the mouth communicating with the interior of the tube f^3 . The use of this catch-basin will be described presently. The central or filtering chamber is connected by several holes, e^2 , with the journal to be lubricated.

To prevent the wheel from running off, the disk c^1 is screwed on the fore part or outer end of the axle c , and a set-screw, c^2 , may be put through it for greater security to prevent the disk c^1 from working loose. The disk c^1 has, preferably, a gun-metal facing, g , where it works against the nave or its cast-steel bush. The aforesaid ring g^1 has a bearing against the inner side of the wheel. The oil is supplied to the oil supply chamber a^3 by taking off the front cover a^2 . When this cover, then, is closed oil-tight no oil can escape in that direction. From the inner side of the nave oil-escape is prevented by a leather ring, d^1 , (or it might be a cup-leather or turned-up collar,) fitted to the nave, and forming joint with the surface of the axle, or with a collar thereon.

The axle has also a groove, l , (or it might be more than one,) between the leather ring d^1 and the journal. The groove is, by preference, of the form here shown—that is, flat or broad at the bottom, and with a sharp edge, the front side to same being vertical and the back sloping; or, instead of a leather ring on or in the nave, a ring, d^2 , as shown at Fig. 4, may be applied, consisting of lead, with a slight addition of antimony, cast on the axle, and formed with one or more grooves, l , as aforesaid, the edge of the nave running on this hard lead ring; or the axle may here be formed with a projecting turned ring, with, say, four parts cut away, and the hard lead ring has corresponding parts cut out of its inner corresponding surface. The lead ring is slipped onto this part of the axle, as shown, for further security, and especially against the entry of dust. A wrought-iron disk, d^3 , may be shrunk on a grooved part of the axle forming joint with the outside of the nave, by means of a leather ring, as shown.

The supply or centrifugal chamber a^3 has in its inner circumference one or more pockets or receptacles, a^4 , and one or more pockets a^4 in the opposite direction. There are here shown four of each. The object of these pockets is to insure a proper lubrication even at the slowest speed where the centrifugal power is not sufficient to distribute the oil all round the inside of the chamber a^3 , and thus enable the tube f^3 to catch it. The catch-basin f^4 on the catch-tube f^3 is a little wider than the pockets, and of suitable length. When the railway wheel revolves slowly all the eight pockets or receptacles a^4 are filled one after another when in their lowest position; four empty themselves again immediately, but the other four carry their oil up and empty it into the basin f^4 of the catch-tube f^3 , whence the oil flows into the tube f^3 , and thence to the filtering-chamber f .

The filter may consist of a perforated tube surrounded by wire-gauze and flannel. After it has been inserted into the central chamber in the axle the opening is closed oil-tight by a stop-screw, f^1 .

The next part of this invention refers also more particularly to railway-wheels; and the special objects attained by this part of the invention are, first, a reduction of vibration, with its consequent molecular changes in the nature of the axle, whereby the metal of same becomes crystalline in its structure, as is well known at the present time; second, a primary reduction of friction of the wearing-surfaces in contact; third, a secondary reduction of such friction by the diminution of the vibration; fourth, a consequent reduction in the wear and tear of rubbing-surfaces; fifth, a diminution of the draft-power required, and, sixth, an increase in the durability of the axle and wheel boss.

By the use of a soft-metal bush in the nave, as heretofore, the evil arises that this bush quickly wears larger in diameter than the

bottom wearing-surface of the axle. The surface of contact between both is thus much reduced, and heat and undue friction and wear result. By the improvements herein described the area of the wearing-surface of nave and axle are little reduced, the wear being practically only in the nave. The proportion found most suitable for the purpose of this invention is to make the width of the axle-bottom wearing-surface about three-fourths of the diameter, and to make the length of the journal about two and a quarter the diameter, at least. This part of the invention is illustrated by Figs. 1 and 1^a, in the first instance, and subsequently by Figs. 4, 6, 7, 8, and 9. The wearing-surface of the revolving nave a is formed with a hard surface, for which purpose it is preferably bushed with a cast-steel bush, e^2 , or the nave a may be cast on a chill, and afterward, if required, ground true. The corresponding axle-journal part is formed with a softer surface, for which purpose it is here coated with gun-metal, bronze, or other alloy. This soft-metal coating e^4 is shrunk, forced, or pressed firmly onto the axle c , and may further be prevented from turning or becoming loose by the set-screw e^3 , preferably inserted endwise in shaft c and coating e^4 , and by a feather or key, or by either of these contrivances, or this may be done by brazing. Fig. 1^a is a sectional view of the coating e^4 . The journal-part of the axle is, for about three-fourths of its length, turned eccentrically, having its eccentricity toward the top, the remaining outer fourth part being concentric with the inner shoulder of the axle, as shown, or it may be only slightly eccentric toward the top, the bottom line forming a continuation of the eccentric part. The coating e^4 of the axle has a flange inside, as shown, working against the cast-steel bush e^2 of the nave. The coating e^4 has by preference the greatest thickness below, as shown, where the wear is greatest, and its outer aforesaid fourth part is a ring, but the remaining three-fourths have the greater portion of the upper half left out. The holes from the central or filter chamber f terminate at the cavity or space e^3 thus formed, and a plentiful supply of oil is maintained here. The wearing-surface at the bottom is only about one fourth of the circumference, in order to save unnecessary friction.

The axle between the horn-plates is, by preference, made of an oblong or rectangular section, as shown at Fig. 3, its greater axis being vertical. In order to bring the springs as near as possible to the wheels, they rest on a bridge or bracket, h , which reaches over the inward-projecting part of the nave a , and is formed with grooves or projecting parts, or both, for holding the axle, which latter is formed with corresponding projecting or slotted parts, or both, to suit. Fig. 5 is a plan of an axle, which, at one end, is formed with projections h^1 and grooves h^2 for the bucket h for the bracket h to fit over and into, re-

spectively. The other end of the same view shows another arrangement, according to which similar parts h^3 are fitted on separately by dovetails, so that they may be replaced when worn. To prevent oscillation, the springs are made somewhat stiffer or stronger than usual.

Fig. 6 is a vertical longitudinal section of a slightly-modified arrangement as to some details. The oil-chamber at the upper part of the axle is here formed between the upper part of the axle and its coating c^1 , and is continued to each end. The ring or disk c^1 , which is screwed onto the end of the axle, and is further secured thereto by a set-screw, c^3 , as shown, is here made of gun-metal, and can take its bearing directly against the cast-steel bush e^2 of the nave, and the axle is formed with a small groove all round communicating with the oil-chamber e^3 . The back flange of the coating-bush c^1 , which can take its bearings against the cast-steel bush e^2 , is formed with oil-grooves for facilitating the access and distribution of oil to this part from the oil-collecting chamber d .

The friction between the end of the axle and the nave is further distributed or taken up by a hard steel block, g^2 , fixed in the end cover a^2 , and taking its bearing against a corresponding hard steel block, g^3 , fixed in the end disk c^1 . The lubrication of these parts is effected by a passage through both, and communicating with a recess formed in the upper part of the edge of the disk c^1 . The set-screw c^3 is, in this case, inserted radially through the disk c^1 . A small set-screw is passed through the front or face of the disk c^1 for holding the steel block g^3 . The filter is held in place by a spiral spring passing round a bush fixed to the block g^3 , and fitting over a central bar formed with a shoulder at the other or inner end. By taking hold of this bar the filter may be withdrawn when required. The brass coating c^1 is, in this case, the same thickness all round except in two places at the oil-passages e^2 , where the chambers are formed extending some distance—say three-fourths—down on each side. The coating c^1 is prevented from turning by a set-screw entering the axle.

In the preceding figures the improvements have been shown applied to cases where the axle does not project out through the nave. I will now describe some constructions of wheel where the axle projects out through the nave and the carriage-springs are outside of the wheels where the load comes on the axle. Fig. 7 is a vertical longitudinal section of a wheel-boss adapted to this construction. The oil is supplied to the nave by means of a stoppered filling-tube, i , passed through the front end of the axle and communicating with the central filtering-chamber in the axle. The upper stoppered opening of this tube i should be higher than the mouth of the catch-tube f^3 in the centrifugal chamber. The means for preventing oil leakage in front is a bush, i^1 ,

fixed on the axle. This bush is formed with one or more annular grooves all round, increasing in diameter toward the inside, and preferably flat or broad at the bottom and with sharp edges, the front side of the edge being vertical and the back sloping. The oil collects here and drops into a surrounding ring-chamber formed in an end cover-ring, a^2 , screwed oil-tight onto the nave, and having a leather ring, v^2 , forming joint with the bush i^1 or the axle itself. The outer gutter-shaped part v^2 of this chamber collects the oil which drops from the nave while at rest, and conducts it into the lower part of the supply-chamber a^3 , or it may drop directly into the same. To prevent the oil splashing from the catch-tube f^3 in the direction of the end cover a^2 , a half ring or shield, v^1 , is fitted or formed on the upper half of the bush i^1 just inside the chamber formed in the cover a^2 , so that the oil drops down from this shield v^1 into the lower part of the centrifugal chamber a^3 without touching the axle.

From the inner side of the nave oil-escape is prevented by similar means, as described with reference to the previous figures. The central filter f is here made in two parts, the filter proper within the journal, and the outer, which is a smaller perforated tube for collecting the oil from the filling tube i . This part may also be covered with wire-gauze.

Fig. 8 is a vertical longitudinal section of a slightly-modified arrangement. The cover a^2 is here formed with one of the annular grooves l , described with reference to the bush i^1 , Fig. 7. The axle has also a similar bush, i^1 , with a similar groove, l , and also with an outer half-gutter-shaped part, v^2 , for collecting the oil dropping from the nave while at rest, and conducting it to the bottom of the chamber a^3 without dropping onto the axle. The central filter is made in two parts, with an intervening empty space for the oil to collect in, so as to insure a free flow of the oil, and thus prevent the stopping up of the filter. The space or cavity e^3 , formed at the upper part of the axle, communicates with the central filtering-chamber by means of a long passage or slit, c^2 , and a hole, e^1 , leads from thence to another cavity, e^5 , at the bottom of the axle. In Fig. 9, which is a half longitudinal section of another modification, the catch-tube f is at the inner end of the nave. The oil-collecting grooves l , at the inner end of the nave, are here formed in the axle itself by the side of the catch-tube, which latter is formed or fitted with a half-shield, v^1 . The oil-collecting grooves l at the outer end of the nave are formed on a bush, i^1 , screwed onto the axle, against which bush a leather ring on the revolving nave forms a joint. The oil-chamber e^3 is broad, and formed by a flat on the shaft at this place, and clogging by dirt is thus prevented, and an even distribution of oil insured.

In the last two figures the nave is provided with a hard-metal bush, e^2 , which may be of some suitable composition run in in a molten

state, the nave being first heated, in order to hold the bush tightly when cooled. Or a hard-metal bush, say of hard phosphor bronze, may be drawn in by hydraulic power, the nave being preferably heated first, and a ring is afterward soldered on at one end, as shown here. The shaft is not shown coated in these two cases, being made of wrought-iron. This arrangement may be applied to any of the first-described construction.

When the wheels are placed inside of the springs, more particularly as regards the arrangement shown at Fig. 6, the springs k rest on bearing-brackets in two halves or parts, h and h^1 , as shown at Fig. 10, and formed with a boss, in which the projecting axle rests with a set-off, to steady the axle axially, and, furthermore, united by feather or key and key-way, to prevent it turning round. The spring holders h^3 pass through the brackets.

Referring to Figs. 7, 8, and 9, it will be observed that these improvements are applicable to the ordinary existing railway-carriages, which can be fitted with fixed axles and loose wheels without altering the other parts of the carriage.

According to another arrangement, namely, when the springs k are outside the wheels, but the axle-supports inside the wheels, a peculiar construction of supporting-brackets, and other parts belonging to the framing for the under carriage, is necessitated. This construction may be as shown at Figs. 11, 12, and 13, Fig. 11 being a side view at one end and a vertical section through line A B, Fig. 12, at the other end. Fig. 12 is half end view and part section through line C D, Fig. 11, and Fig. 13 as a horizontal section through E F, Fig. 11.

On the fixed axles c , and just inside the wheel-bosses a , rest two longitudinal girders, m , fixed thereto by bolts and nuts h^2 . In front and behind each pair of wheels, and projecting beyond them, a cross-girder, n n^1 , is placed transversely on the aforesaid longitudinal girders m , and secured thereto. The inner cross-girders n^1 are stayed by slanting ties or struts n^2 , and the outer ends of each pair of cross-girders n n^1 are united by a girder, o , outside the wheels. The eyes n^3 , or other attachments for holding the ends of the springs k , are fixed to the cross-girders n n^1 , the springs being placed upside down, as compared with the usual mode. At each wheel a frame, p , is fixed to the longitudinal girders q of the carriage-body, and each of these frames p

has vertical grooves, as shown clearly at Fig. 13, which is a cross-section of same.

By thus being able to place the springs outside the wheels greater stability is obtained for the carriage.

When the naves are made separate from the wheels, as in the examples here illustrated, the important advantage is gained that the nave can be used again for a new wheel when the old wheel is worn out. The naves may be of cast-steel, and then, of course, lighter than here shown.

Fig. 14 is a vertical section of a belt-pulley with my improved means of lubrication shown applied. Fig. 14^a is a section of Fig. 14 at line A B, and Fig. 14^b an end view of closing-cover a . a is the wheel-boss; a^3 , the oil-chamber; f , the catch-tube, and e the communicating passages.

The lips of the boss a , which overlap the axle c , may, if preferred, be caused to form a tight joint therewith by means of a leather or lead ring. Grooves l are also provided for the purposes hereinbefore described.

And having thus fully described the nature of this invention, I declare that I claim—

1. The coating c^4 , in combination with an axle, c , an internal filtering-chamber, f , one or more passages, c^2 , and oil-chamber e^3 , substantially as set forth.
2. The coating c^4 , in combination with the ring or bush i , disk e^1 , ring g^1 , and hard blocks g^2 g^3 for keeping the nave in place on the axle shaft or stud, and taking the axial end thrust or wear of one against the other, substantially as set forth.
3. The boss or nave of a wheel revolving loosely on its axle, and formed with a chamber, a^3 , pockets a^4 , and catch-basin f^4 , chamber d , and one or more slanting communicating passages, e , in combination with a catch-tube, f , fastened to the axle shaft or stud, a passage, f^2 , a filtering-chamber, f , and passage or passages c^2 , communicating with the upper journal wearing-surface, substantially as set forth.
4. The pockets a^4 , formed or fitted in a revolving nave, and the catch-basin f^4 , in combination with a pipe or passage for leading the oil from the basin f^4 to the journal, substantially as and for the purposes set forth.

JOHANNES AUGUST OSENBRÜCK.

Witnesses:

FRITZ OSENBRÜCK,
ADOLF OSENBRÜCK.