

J. DRAKE.

VENTILATORS FOR CHIMNEYS.

No. 190,294.

Patented May 1, 1877.

Fig: 1.

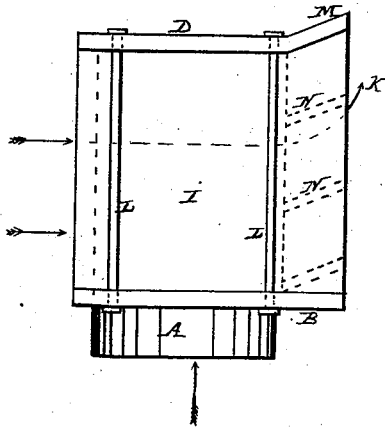

Fig: 2.

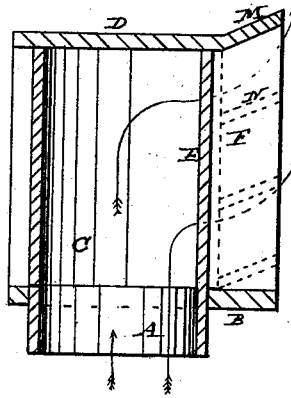

Fig: 3.

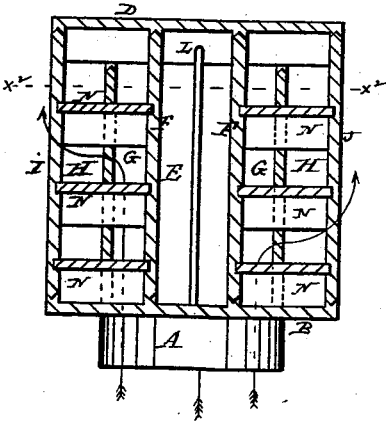

Fig: 4.

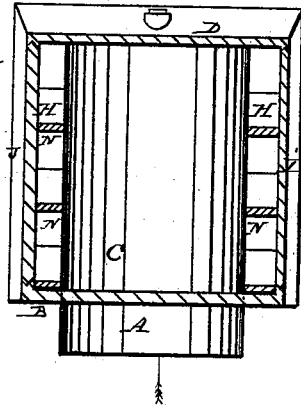
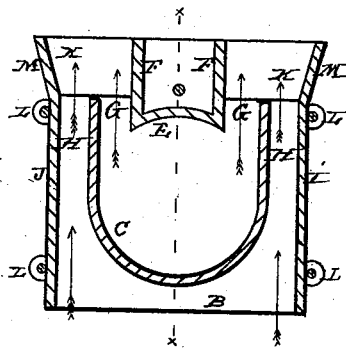

Fig: 5.



Witnesses
Walter Prinsie
J. Calver

Inventor
Jacob Drake
by atty
Ch. Parrott

UNITED STATES PATENT OFFICE.

JACOB DRAKE, OF NEW YORK, ASSIGNOR OF ONE-HALF HIS RIGHT TO
ANDREW VAN HORN, OF BROOKLYN, N. Y.

IMPROVEMENT IN VENTILATORS FOR CHIMNEYS.

Specification forming part of Letters Patent No. 190,294, dated May 1, 1877; application filed
March 23, 1877.

To all whom it may concern:

Be it known that I, JACOB DRAKE, of the city, county, and State of New York, have invented a new and Improved Ventilator for Chimneys and other purposes, which improvement is fully set forth in the following specification and accompanying drawings, in which—

Figure 1 is a side elevation of the ventilator. Fig. 2 is a vertical cut section of the same through the line *x x*, Fig. 5. Fig. 3 is a back-end view of the ventilator. Fig. 4 is a front-end view of the same. Fig. 5 is a plan view through the line *x² x²*, Fig. 3.

The same letters of reference, wherever they occur in the drawings, refer to similar parts.

The object of my invention is to obtain a full exhaustion of the smoke rising in the chimney, and at the same time prevent all back currents of air entering it, or being choked up by drifts of snow; and the nature of my invention consists in combining, with a double-slotted U-shaped vertical smoke-pipe, a square box or case, with open ends front and rear for the passage of currents of atmospheric air through the box, externally of the smoke-pipe, for the purpose of exhausting the smoke from the chimney, and carrying off the same as fast as it escapes from the slots in the vertical pipe.

Letter A represents the pipe for connecting the ventilator to the chimney, having its upper side secured to the lower side of the box or bed-plate B of the ventilator. On the upper face of the bed-plate is secured a vertical smoke-pipe, C, of about one-third greater length than the diameter of the pipe A, and hermetically closed at its upper end by a cap-plate, D, forming the top of the box. The pipe C, at its front side, is curved, and about of the same diameter as that of the pipe A, so as to allow the smoke to ascend into it freely. Its back side is made open, forming a U-shaped outline, with the open ends of the U extending a little way beyond the diameter of the circle of its front end, as represented in Fig. 5. Between the ends of the U is interposed a deflector, E, having side walls F,

which project beyond the ends of the sides of the U to the full depth of the end of the box.

By this means the rear or open side of the vertical smoke-pipe is divided into two slots, G, for the escape of the smoke. The object of this is, first, to cause the smoke to escape in a sheet as it ascends the length of the slots, and thus be more readily acted upon by the passing currents of atmospheric air through the box than if the smoke was allowed to escape by a circular aperture; and, second, for the purpose of compelling the sheet of smoke, as it escapes by the slots, to impinge upon the currents of air passing through the space H between the pipe and side plates I and J of the box, as indicated by the arrows K, Fig. 5.

These several plates, forming the case or box in which the vertical smoke-pipe is arranged, are intended to be made in separate pieces, and secured together by rods L, or by any other suitable means for such a purpose. The sides of the case or box, at its front and rear ends, extend beyond the greatest diameter of the U of the smoke-pipe some twelve inches, more or less, as may be deemed best, for the admission of the currents of atmospheric air, and discharge of the same and smoke from the rear end of the ventilator.

To cause the smoke to escape more freely, the rear end of the box is made flaring, as shown at letter M, Figs. 1 and 5.

For the purpose of deflecting the smoke upward as it escapes from the rear end of the ventilator, one or more slats, N, are arranged in an upward-slanting position across the vertical slots in the smoke-pipe, and air-passage-ways at the side of it, and between the walls F of the deflector E and the sides I and J of the box. By this means the sheet of smoke is not only broken to facilitate its escape, but at the same time is enabled more readily to commingle with the passing current of atmospheric air through the box.

For the purpose of adapting the ventilator to the varying changes of wind, it is designed to surmount it with a vane and support it on

a spindle, in the common and well-known way of making revolving ventilators.

Having now described my invention, I will set forth what I claim and desire to secure by Letters Patent of the United States:

1. The combination of the U-shaped vertical smoke-pipe C with the deflector E, having its sides F within the mouth of the U, and extending beyond the same to the end of the case or box, as and for the purposes set forth.

2. The combination of the U-shaped vertical smoke-pipe C and deflector E, having side walls F, as described, with the side plates I and J of a square box, and air-passage-ways

H between them and the sides of the vertical smoke-pipe, as and for the purposes set forth.

3. The combination of the horizontal slats N, side walls F of deflector E, slots G of vertical smoke-pipe, and atmospheric-air passage-ways H, all arranged and operating as and for the purposes described.

JACOB ^{his} X DRAKE.
mark.

Witnesses:

BENJN. DEAKE,

ANDREW VAN HORN.