

J. M. FORNEY.  
DRAFT EQUALIZER.

No. 190,302.

Patented May 1, 1877.

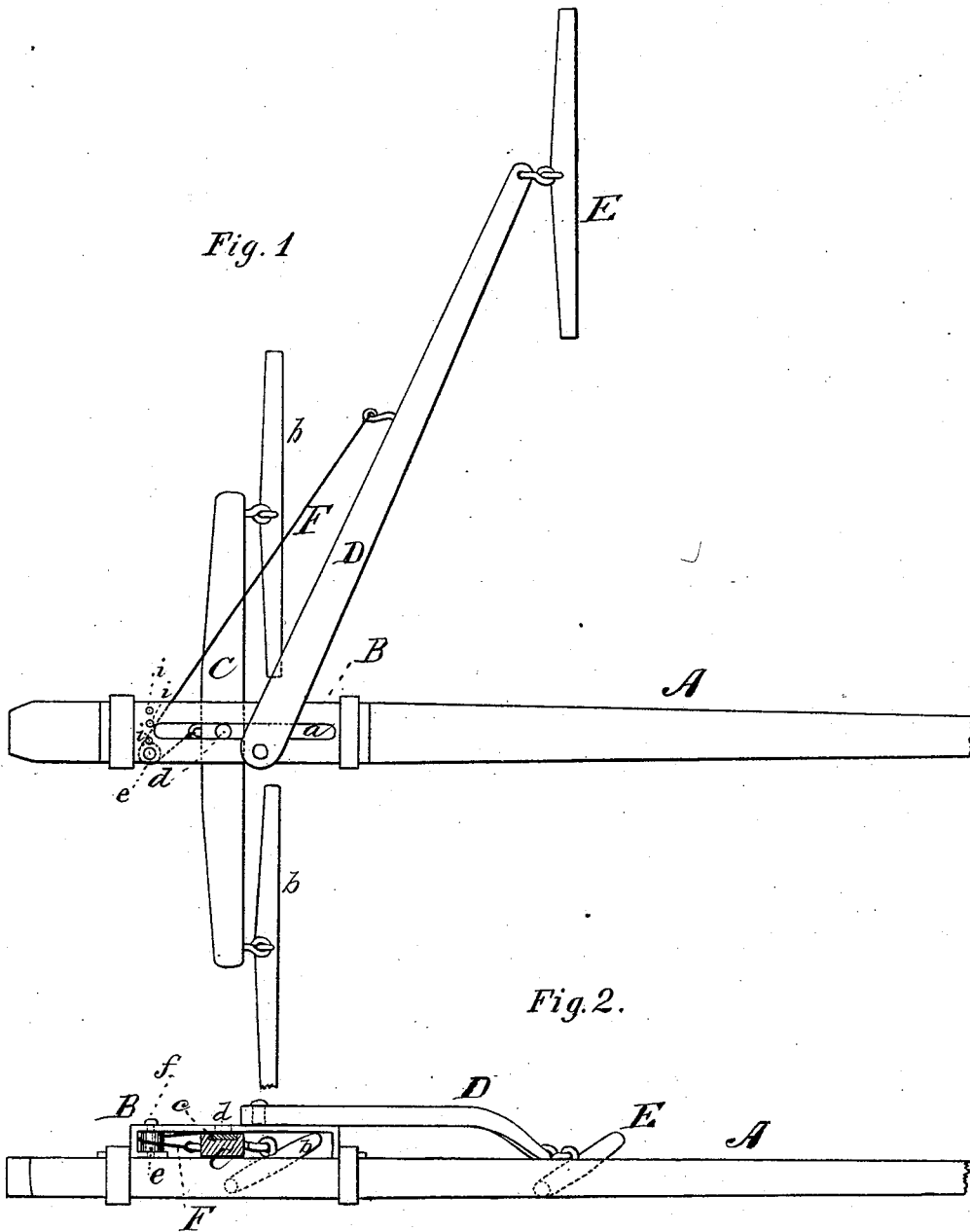

WITNESSES  
*Walter C. Massi*  
*A. J. Massi*

INVENTOR  
*John M. Forney,*  
*by E. W. Anderson,*  
ATTORNEY

# UNITED STATES PATENT OFFICE.

JOHN M. FORNEY, OF VICTOR, IOWA.

## IMPROVEMENT IN DRAFT-EQUALIZERS.

Specification forming part of Letters Patent No. 190,302, dated May 1, 1877; application filed March 10, 1877.

### *To all whom it may concern:*

Be it known that I, JOHN M. FORNEY, of Victor, in the county of Iowa and State of Iowa, have invented a new and valuable Improvement in Three-Horse Equalizers; and I do hereby declare that the following is a full, clear, and exact description of the construction and operation of the same, reference being had to the annexed drawings, making a part of this specification, and to the letters and figures of reference marked thereon.

Figure 1 of the drawings is a representation of a top view of my improved equalizer, and Fig. 2 is a side view thereof, partly in section.

This invention has relation to improvements in three-horse equalizers; and it consists, first, in a bridge-cap passing over the pole, near its junction with the hounds, adapted to receive the double-tree between it and the said pole, and provided with a longitudinal slot adapted to receive a pin or bolt on the tree, whereby the said tree is capable of a vibratory movement relative to the said pole, and also of a parallel movement to the front or rear.

It also consists in the combination, with a pole and a longitudinally-slotted bridge-cap secured thereto, of a horizontally-vibratory and front and rearwardly movable double-tree, a lever pivoted at one end to the said bridge-cap, and carrying the single-tree upon its other end, a pulley upon the bridge-cap, and a chain or rope extending from the double-tree to the rear over said pulley, and to the front to said lever.

It also consists in combining with a vibratory third-horse lever pivoted to the pole and a double-tree, having a front and rear and vibratory movement relative to said pole, a rope or chain passing around a laterally-adjustable pulley and connecting the said lever and double-tree, whereby the power of the single-tree lever relative to that of the double-tree may be readily increased or diminished according to the strength of the third horse, all as hereinafter shown and described.

In the annexed drawings, the letter A designates the pole of a vehicle, plow, cultivator, or other device drawn by horse-power. B represents a strong metallic bridge-strap provided with a longitudinal slot, *a*, and rig-

idly secured to the pole by means of bolts, or otherwise, at, near, or in rear of its junction with the hounds of a vehicle or other like device. C represents an ordinary double-tree, having at each end the usual single-tree *b*, and provided at the middle of its length with a strong metallic plate, *c*, having a round spur, *d*.

The double-tree is located, when in use, under the bridge-strap, and the spur *d* of its plate *c* is engaged in the slot *a* thereof, so that the said tree has not only the usual vibratory movement, but also one to the front and rear.

D indicates a lever pivoted to the bridge-strap or to the pole at a point near the middle of the length of the former, and carrying on its free end the usual single-tree E.

This lever is connected with the double-tree by means of a rope or chain, F, extending from the former to the rear over a pulley, *e*, whence it is carried and attached to the lever aforesaid.

It is evident that this construction of an equalizer causes an equilibrium of forces—that is, causes each and every horse to bear its due proportion of the draft.

Pulley *e* is adjustable laterally relative to the pole by means of a pin or bolt, *f*, having its bearings in the bridge-strap and pole. The pin or bolt extends through the said pulley, and is capable of being shifted to one side or the other through spaced perforations *i* formed in the said bridge and pole.

By this means the power exercised by the lever D may be regulated according to the strength and disposition of the third horse.

What I claim as new, and desire to secure by Letters Patent, is—

1. In combination with the pole A, having bridge-strap B, provided with slot *a*, the double-tree C, having plate *c* and spur *d*, substantially as specified.

2. The combination of the pole A, having the longitudinally-slotted bridge-strap B, provided with pulley *e*, with the third-horse lever D, and the rope or chain passing over said pulley, and secured at its ends, respectively, to the double-tree and lever, substantially as specified.

3. The laterally-adjustable pulley *e* and cord F, in combination with the vibrating lever D, and the vibrating and front and rearwardly movable double-tree C, substantially as specified.

4. The longitudinal bridge-strap B, having slot *a*, in combination with the double-tree *c*, having a projecting spur working in said slot, substantially as specified.

5. The combination, with a vibrating lever, D, a draft-pole, A, and a vibrating and front

and rearwardly movable double-tree, of the bridge-strap B, having spaced perforations *i*, the pulley *e*, the pin *f*, and rope or chain F, substantially as specified.

In testimony that I claim the above I have hereunto subscribed my name in the presence of two witnesses.

JOHN M. FORNEY.

Witnesses:

S. B. CUSHEN,  
JOHN DOBBS.