

J. GREEN.

FORMERS FOR MAKING FOLLOWER-PLATES FOR DRAWHEADS.

No. 190,315.

Patented May 1, 1877.

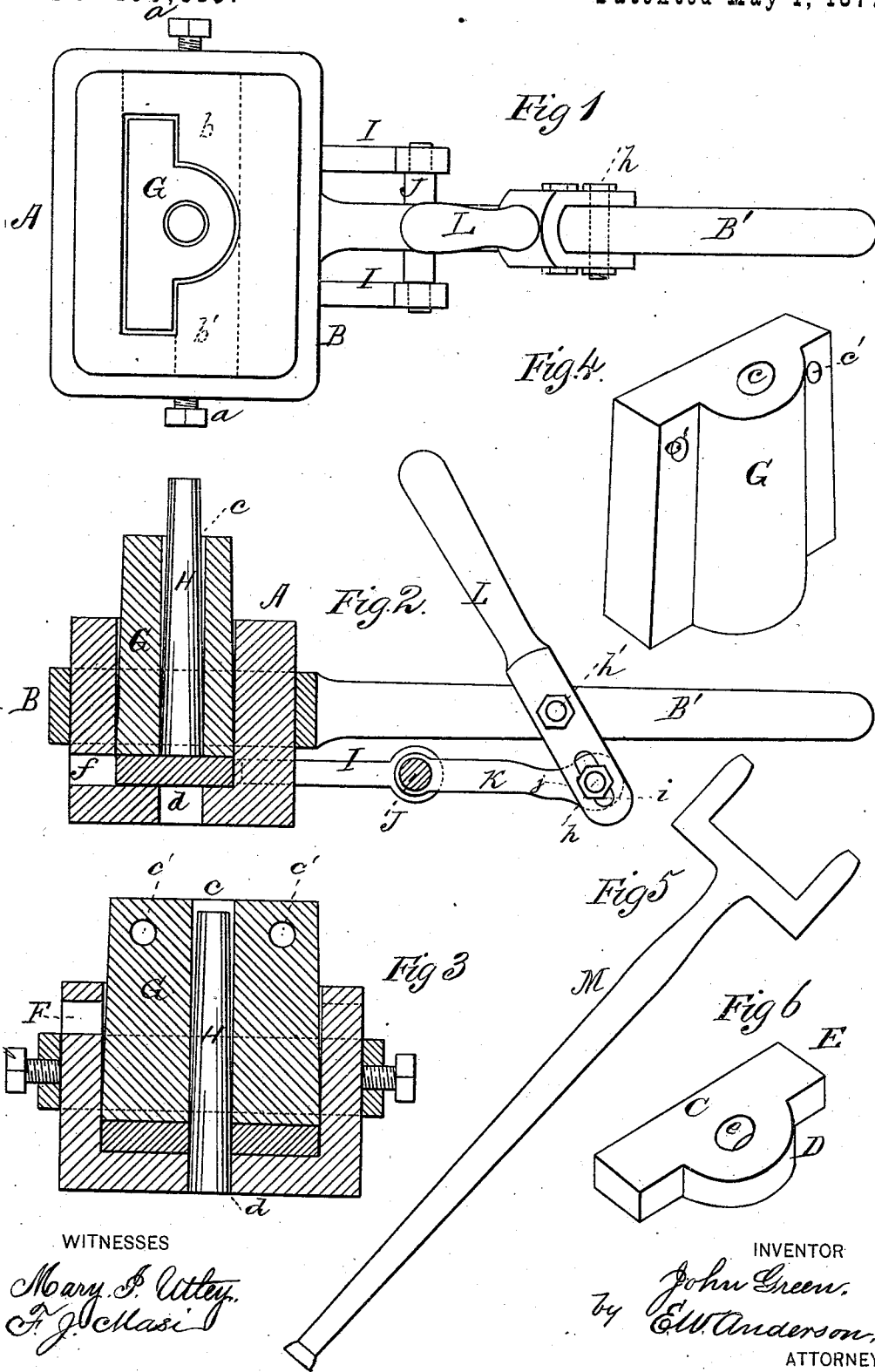

WITNESSES

Mary S. Utley.
A. J. Chasie

INVENTOR

John Green.
by E. W. Anderson,
ATTORNEY

UNITED STATES PATENT OFFICE.

JOHN GREEN, OF SUNBURY, PENNSYLVANIA, ASSIGNOR OF ONE-HALF HIS RIGHT TO JOHN M. McKEE, OF SAME PLACE.

IMPROVEMENT IN FORMERS FOR MAKING FOLLOWER-PLATES FOR DRAW-HEADS.

Specification forming part of Letters Patent No. 190,315, dated May 1, 1877; application filed March 24, 1877.

To all whom it may concern:

Be it known that I, JOHN GREEN, of Sunbury, in the county of Northumberland and State of Pennsylvania, have invented a new and valuable Improvement in Formers for Making Follower-Plates for Draw-Heads used on Railroad-Cars; and I do hereby declare that the following is a full, clear, and exact description of the construction and operation of the same, reference being had to the annexed drawings, making a part of this specification, and to the letters and figures of reference marked thereon.

Figure 1 of the drawings is a representation of top view of my invention. Fig. 2 is a longitudinal section thereof. Fig. 3 is a vertical cross-section of the same; and Figs. 4, 5, and 6 are detail views.

My invention has relation to improvements in "formers" for making follower-plates for the draw-heads of cars.

The object of my invention is to devise a former and die which will make the follower-plates of precisely the same size, and turn them out in a finished condition ready for use.

The nature of my invention will be fully understood from the following description:

In the annexed drawings, the letter A designates a hollow metallic box, preferably of rectangular form, and made in one or more parts, as I may elect. In either case the former will have a strong metallic yoke, B, carrying a handle, B', by means of which the box can be conveniently handled, and this yoke will be adjusted on the box by means of set-screws *a*. The hollow of the box will be in shape that of the usual follower-plates—that is, of a rectangular bar, C, having a semicircular enlargement, D, on one edge, as shown in Fig. 6.

Box E is slotted through, near its upper edge, from side to side, and the breadth of this slot F being somewhat greater than that of the follower-plate designed to be formed, sideways *b b'* are made, in which the blank will be received. This blank is rectangular in form, and is passed into the body A through one end of the slot F.

When the blank is in place its end bears against the side wall, and the opening of the

box is completely closed. In this position the die G is placed in the box, with its cutting-face resting upon the blank, and the box is placed under the steam-hammer. Die G is in cross-section of precisely the same construction and form as the follower-plate E, which it is designed to cut, and it conforms snugly to the contour of the box; consequently, when the die is forcibly struck by the hammer, it will cut out of the blank a plate of precisely the same shape as its cutting-face. The die G is provided with spaced perforations *c'* at its upper edge, and with a circular opening, *c*, extending through it from end to end, that registers with a corresponding perforation, *d*, in the bottom of the box A. When the plate has been cut by the die out of the blank, it is forced to the bottom of box A, where it covers the perforation *d*. An ordinary punch, H, is then thrust into opening *c* of the die until it bears against the said plate, and is struck by the hammer with sufficient force to cut the orifice *e* in said plate, the clipping cut out by said punch falling out of perforation *d*. After orifice *e* in plate E has been made, the upper end of punch H will be flush with the upper end of the die G. The box containing the follower-plate and the die is then placed under the hammer, and the plate E accurately flattened out, so as to do away with burrs or flanges produced by the action of the die, by a blow or blows of the hammer on the die. This being accomplished, the plate E is thrust out of the box A through a slot, *f*, of suitable dimensions, by means of pushers I, that extend through spaced perforations in the wall opposite slot *f* aforesaid. These pushers afford bearings in their outer ends for a cross-head, J, having a connecting-rod, K, secured at its outer end to a lever, L, fulcrumed on handle B', by means of a bolt, *h*, passing through oblong slots *i* in the furcated end of said lever, and an eye, *j*, in the end of said rod.

By this means the pushers I are actuated in a right line, and are prevented from bending in the box, and as they act at the ends of the plate E it is forced out without jamming in box A or the exit-slot *f*.

As shown in Fig. 1, the slides *b b'* are on

the same side of the opening into the box A, and the end of the blank abuts against the end of the box without entering the slot; consequently, only one side (that having the curvature) and one end of the blank (that next the entrance of slot F) require to be cut by the die. This die is removed from the die-box by means of the forked rod M.

Having described my invention, what I claim as new, and desire to secure by Letters Patent, is—

1. The combination, with the die-box A, having slot F, slideways *b b'*, the punch-aperture, and exit-slot *f*, of the die G, having a central orifice, *c*, registering with the orifice *d* aforesaid, substantially as specified.

2. The combination, with a die-box, A, having an exit-slot for the struck-out plate, of the pusher-rods I and the cross-head J, connect-

ing said pushers, the connecting-rod K, and a vertically-vibrating lever, L, substantially as specified.

3. In combination with a die-box, the yoke B, embracing said box, and provided with a handle and set-screws, substantially as specified.

4. In combination, the die-box A, having exit-slot *f*, the spaced pushers I, the cross-head J, its connecting-rod K, having an eye, *j*, the furcated lever L, having oblong slots *i*, and the pivot-bolt *h*, substantially as specified.

In testimony that I claim the above I have hereunto subscribed my name in the presence of two witnesses.

JOHN GREEN.

Witnesses:

R. P. MCCARTNEY,
T. D. GRANT.