

H. WELLINGTON.  
GASOLINE COOKING STOVES.

No. 190,393.

Patented May 1, 1877.

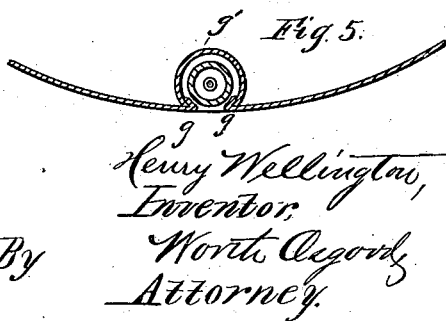
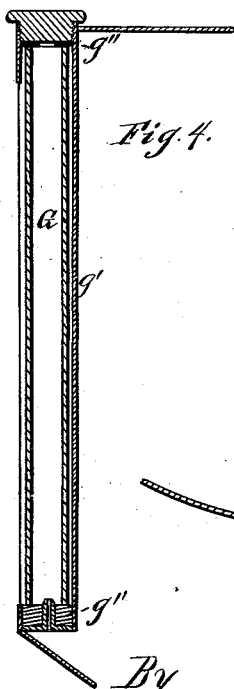
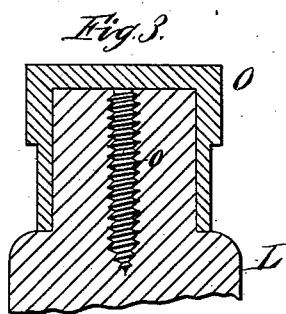
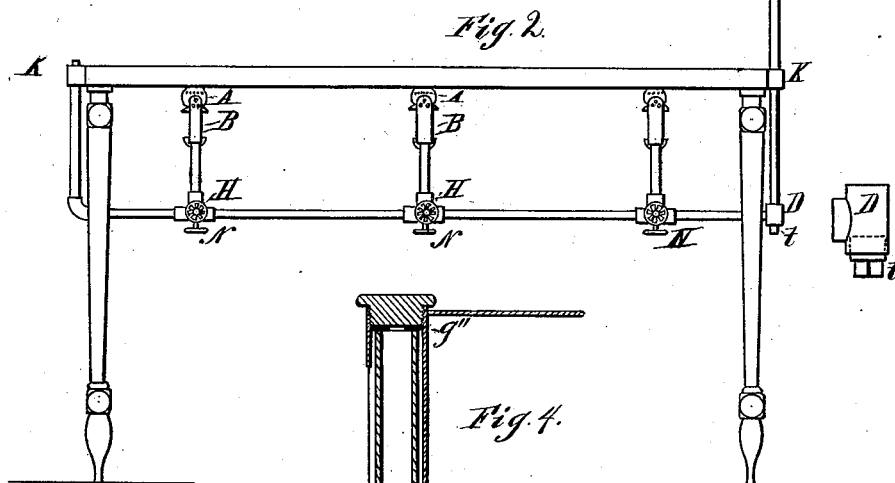
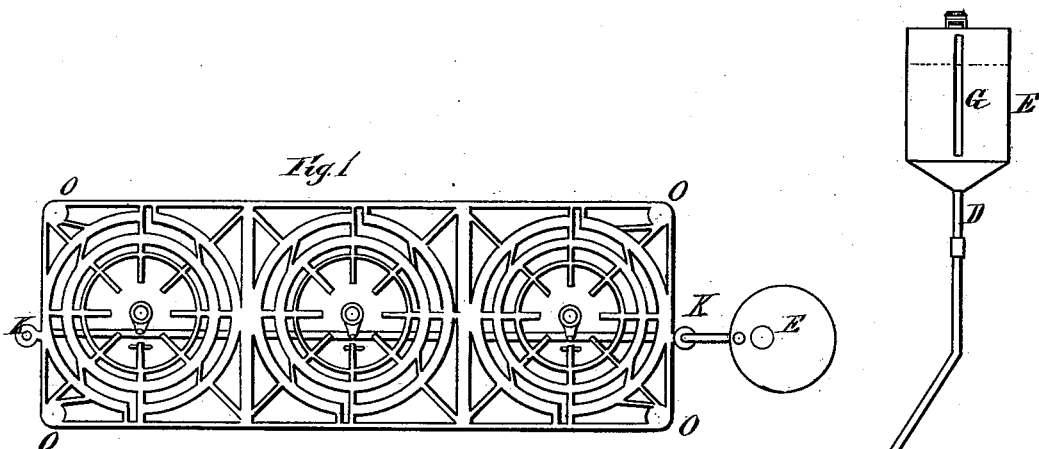

Attest.  
C. H. Searle,  
N.P. Clerk.

By

Henry Wellington,  
Inventor,  
North Ogden,  
Attorney.

H. WELLINGTON.  
GASOLINE COOKING STOVES.

No. 190,393.

Patented May 1, 1877.

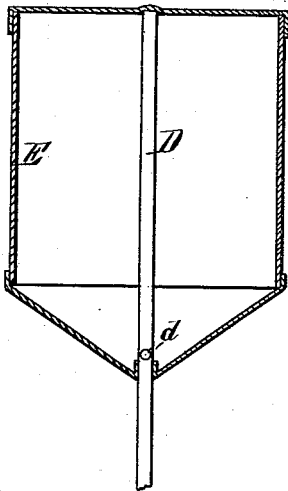
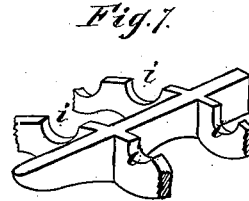
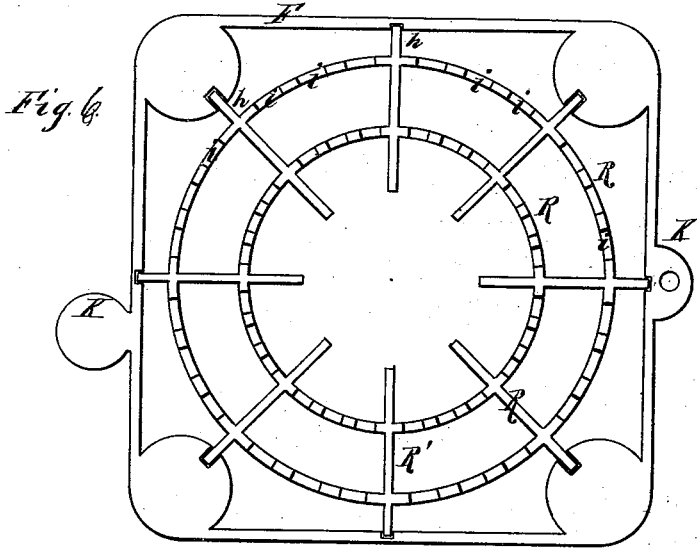

Fig. 10.

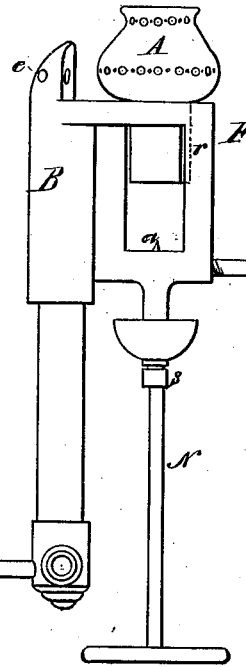

Fig. 8.

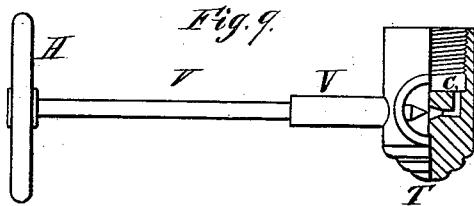

Fig. 9.

Attest.  
*C. H. Smith*  
*D. P. Lowe*

*Henry Wellington,*  
 Inventor.  
*North Ogden,*  
 Attorney.

# UNITED STATES PATENT OFFICE.

HENRY WELLINGTON, OF BROOKLYN, E. D., NEW YORK.

## IMPROVEMENT IN GASOLINE COOKING-STOVES.

Specification forming part of Letters Patent No. **190,393**, dated May 1, 1877; application filed March 14, 1877.

*To all whom it may concern :*

Be it known that I, HENRY WELLINGTON, of Brooklyn, E. D., county of Kings, and State of New York, have invented certain new and useful Improvements in Gasoline Cooking-Stoves, of which the following is a full, clear, and exact description, reference being had to the accompanying drawings, and to the letters of reference marked thereon.

Figure 1 is a plan view of my improved stove, and Fig. 2 a side elevation thereof, showing the location of the burners and supply-pipe, and the legs supporting the whole metallic structure. Fig. 3 is a section of the stove-leg socket and a portion of the leg, illustrating the method adopted for securing the two together. Fig. 4 is a vertical section, and Fig. 5 a horizontal section, of a portion of the oil can or fount, showing the manner of inserting a gage-tube. Fig. 6 is a plan view of the most approved form of top plate, showing the method of supporting the supply-pipe therefrom; and Fig. 7 is a perspective view of a small portion of said plate, exhibiting more clearly the form given the supporting-bars thereof. Fig. 8 is a side elevation of a burner, and Fig. 9 a detail view of the T-joint employed for connecting said burner with the supply-pipe. Fig. 10 is an axial section of the oil can or fount, showing the means of supporting the same.

Like letters in all the figures refer to corresponding parts.

My invention has relation to that class of devices known as "gasoline-stoves" or "vapor-burning stoves;" and it consists, first, in certain improvements upon the burner, by means of which the conversion of the oil into gas is rendered certain and easy to be accomplished; second, in the means adopted for connecting the burner with the supply-pipe, whereby greater facility in manipulation and increased advantages are secured; third, in certain improvements on the top plate of the stove, rendering the same not liable to warp and crack under the excessive heat, adapting it for use with one, two, or more burners, and furnishing means for supporting the oil-supply pipe; fourth, in the means employed for supporting said top plate, and the method of connecting the legs thereto; fifth, in an improved method

of connecting the oil fount or reservoir with the supply-pipe, all of which will be first fully described, and then pointed out in the claims.

In the drawing, A is a removable cone-shaped top, usually denominated the "burner or mixing chamber." It receives the combined air and gas, and burns the mixture in the usual way. B is the oil-tube of the burner, leading to the gas-orifice *a*. In order to facilitate the necessary conversion of oil into gas, I extend the tube B upward slightly beyond the face which supports the cone, and perforate this extension above the oil-passage, as at *e*, Fig. 8; and in the cone I make two or more perforations, in such position that the burning gas will be directed through the before-mentioned perforations in the pipe B, and serve as an auxiliary heating-flame. The close proximity of said auxiliary flame to the oil in the pipe B and the conducting powers of the material of which the pipe is made render this a very efficient means of accomplishing the desired ends. In order that the auxiliary jets may always assume the proper direction, the removable cone is provided on one side with a rib, *r*, which fits in a corresponding groove cut in the burner-frame; and this insures a certain location of the cone whenever it is placed in position for burning.

In order that two or more burners may be located beneath the top plate of the stove and upon the same supply-pipe, it is desirable that the flow of oil to either may be regulated independently of any other, and at the same time the valve-stems of the oil-cocks should project toward the front of the stove, so as to be convenient for handling, and at the same time removed from the vicinity of the needle-valve stem N, for greater facility in manipulating the latter. To provide for these desirable features I have designed a T joint or connection between the burner and the supply-pipe, which is constructed substantially as follows:

At right angles to the lower portion I form the valve-stem socket, which is screw-threaded throughout its entire length in order to properly receive said stem. The oil-channel corresponding to the direction of the supply-pipe is so cored out as that it shall be

of about half the size of said pipe, the remaining portion of the joint remaining solid until properly drilled to form the necessary valve-seat and vertical oil-channel leading to the oil-tube of the burner.

V is the valve-stem, and V' its socket. The valve is considerably smaller than the horizontal oil-channel, and thus permits the oil to flow past it to other burners beyond without interference. The valve-seat is located accurately in the direction of the socket V', and the oil-channel from said seat is drilled through to intercept the vertical channel *c* within the solid portion of the joint, and leading up to the burner above. By use of this joint I am enabled to accomplish the results specified, and also to remove the valve-stem handle H from beneath the flame, where heretofore it has commonly been placed.

The top plate of the stove, upon which the cooking-utensils rest, is made of cast-iron, as being the most suitable metal for the purpose. Considerable annoyance has been occasioned by the cracking and warping of the plate under the intense heat, and many experiments have been made with a view of avoiding this difficulty. It is essential that the top plate be in the form of open work, so arranged as to properly support the smallest articles of stove-furniture, and yet afford as much space as possible for contact of the flame with said articles. When constructed in the fanciful form shown in Fig. 1, the second of these considerations is perfectly attained; but it is found that the objection alluded to is not entirely obviated.

In Figs. 6 and 7 is shown a construction and arrangement of the bars forming the open-work, which is found highly satisfactory, and all that is desirable with respect to the above.

Two or more rings, R R, are united by the radial pieces R' R', the parts being at suitable distances from each other, and of uniform thickness horizontally, which renders them about equally expandible. The tops of the rings R R are indented, as at *i i*, &c., (more clearly represented in the perspective view, Fig. 7;) and similar indentations may be made on the under sides, if desired. These indentations afford the requisite passages for the flame, and also probably assist in preventing the cracking alluded to.

It is desirable that provision be made for increasing the size of the stove, so that any number of burners may be employed. This may be done, as indicated in the plan view, Fig. 1, by casting the required number of sections in one piece, which renders the top plate quite firm and substantial, and is withal a very desirable method of construction; or, by making the open-work removable from the frame thereof, this frame may be of any required length, and the several sections made up by inserting the corresponding number of open-work plates. This construction

is shown at Fig. 6, wherein the frame F is provided with suitable sockets *f f*, &c., adapted to receive and hold the projections *h h*, &c., upon the open-work plate R R'.

The operation of this feature of the invention is apparent from the drawing, and needs no further description.

Aside from the advantages alluded to above, the removable open-work is readily replaced, in case it be broken by any accident, without necessitating an entire new top plate.

The oil-supply pipe has heretofore been attached to the legs of the stove or the top plate by means of separate clamps or couplings, which attachment was insecure, and difficult and expensive to make. I have conceived the idea of casting two lugs, K K, with the top plate or its frame, one at each end, as indicated at Figs. 1, 2, and 6, and passing the supply-pipe D through these.

The pipe is carried completely under the stove from one end and turned up toward the other end, in order to attach it to the opposite lug, by reason of which arrangement the reservoir may be located at either end of the stove, as desired. The end opposite the reservoir should, of course, be plugged up in some suitable manner.

In the larger stoves these lugs are usually thrown a little to one side of the central line, as shown in Fig. 1 and at the left of Fig. 6; but for the smaller sizes, or single burners, they are generally placed on said central line, as shown at the right of Fig. 6. This method of attachment renders the connection between the supply-pipe and the stove firm and durable, and it is, at the same time, cheaper and better than the old method, or any other now known to me.

The support for the top plate is a very important feature of the invention. The stove should be elevated to about the height of an ordinary cooking-stove, and the whole structure should be made as light as is consistent with the nature of the offices it has to perform, that it may be moved from one position in the room to another. I find that wooden legs are the best and cheapest for the purpose, all things being considered. The legs are secured at the four corners of the stove, as in Figs. 1, 2, and 6, and for the larger sizes may be braced by suitable wooden stays running from one to the other.

Fig. 3 shows an enlarged view of the corner socket O, which is made sufficiently deep to securely hold the leg L against any lateral movement. A screw, *o*, is embedded in the center of the socket, (preferably in the casting,) and enters the upper end of the leg, thereby securing the same against withdrawal, except by purposely unturning it. This construction enables me to separate the legs from the top, if needed, in order to pack the structure in a narrow compass, and otherwise fulfils all the objects of this portion of the invention.

Since the reservoir occupies an elevated position with respect to the stove, and is supported solely by the feed-pipe, it is essential that the two be connected as rigidly as possible; and this I accomplish by projecting the feed-pipe D up through the reservoir E until its extremity touches the under side of the top thereof and bears closely against the same. A slight indentation may be provided in the top for the reception of the end of the pipe, or any convenient means of attachment or connection may be employed.

Within the reservoir and near the bottom thereof the pipe D is perforated, as at *d*, Fig. 10, through which perforations the oil finds its way into the pipe.

In this class of stoves it is desirable to have a sufficient quantity of oil in the reservoir before lighting the burners in order that it will not be necessary to introduce any oil while the stove is in operation; and on account of the elevated position of the reservoir, it frequently occurs that the filling is continued until the oil flows over the filling-orifice.

To afford a means of determining the quantity of oil in the reservoir, I attach a gage-tube thereto, as shown at G, Figs. 4 and 5, which I prefer to locate within the oil-reservoir, as indicated, so that it may not be damaged in shipping, or by any accident while in use. For this feature I propose to apply for separate Letters Patent.

In order to remove any sediment or other obstruction which may find its way into the supply-pipe D, or to draw off the oil in the can E, as is sometimes found necessary, I place a screw-plug, *t*, at one of the angles in said pipe. By removing this plug the oil may be withdrawn without detaching the burners, and the operation of cleaning out the pipes may be accomplished by introducing a wire or rod.

Having thus fully described my invention, what I claim as new, and desire to secure by Letters Patent, is—

1. In a gasoline-burner of the character herein specified, the combination, with the removable cone of the extended portion of the oil-pipe elevated above the cone-seat and perforated to permit the passage of the auxiliary heating-jets from said cone, substantially as shown and described.

2. In a gasoline-burner of the character herein specified, the combination of the re-

movable cone, having a feather or rib, *r*, and the slotted or grooved frame which forms a portion of the burner and a seat for the cone, substantially as and for the purposes set forth.

3. In combination with the supply-pipe of a gasoline cooking-stove, conducting oil to two or more burners, the herein-described T-joint, adapted to attach said burners to the supply-pipe and afford a passage for the oil thereto, the same being provided with a valve-stem socket and seat, and otherwise constructed and arranged as shown and described.

4. In combination with the frame of the top plate for gasoline cooking-stoves, constructed substantially as shown and described, the removable open-work top plates, provided with projecting ribs adapted to engage with corresponding slots in the frame, substantially as shown.

5. In an open-work top plate for gasoline cooking-stoves, the combination of the rings R R and radial pieces R' R', the former being indented, as shown, and the two being of about equal horizontal section, as and for the purposes explained.

6. In combination with the open-work top plate of a gasoline cooking-stove, the wooden legs adapted to support the whole metallic structure, as set forth.

7. In combination with the open-work top plate of a gasoline cooking-stove, cast with corner-sockets O O, and screws depending therein, the wooden legs L secured in the manner set forth.

8. In combination with the top plate of a gasoline cooking-stove, the lugs K K cast therewith and adapted to secure and hold the supply-pipe D, in the manner shown and described.

9. In combination with the elevated reservoir of a gasoline cooking-stove, the perforated supply-pipe D, terminating within said reservoir and abutting against the top plate thereof, for the purpose of rigidly supporting said reservoir, in the manner shown and described.

In testimony that I claim the foregoing, I have hereunto set my hand in the presence of two witnesses.

HENRY WELLINGTON.

Witnesses:

C. R. SEARLE,  
GEO. F. GRAHAM.