

C. M. CARNAHAN

CAR-COUPLING.

No. 190,418.

Patented May 8, 1877.

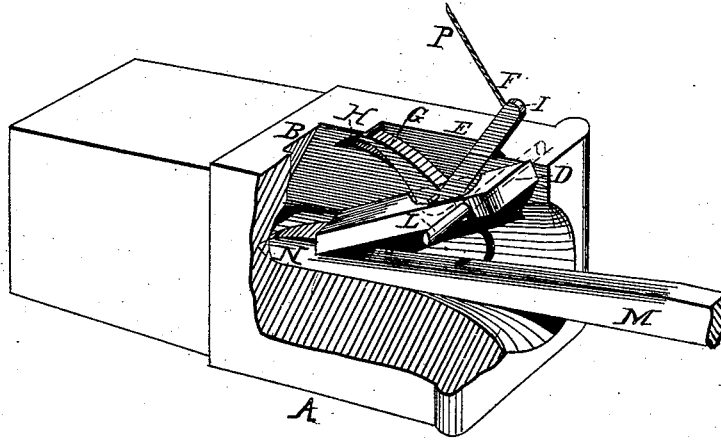

Witnesses

*Chas. Gill*  
*H. M. Dowell*

Inventor

*Cyrus M. Carnahan*  
*by his Attys.*  
*Cox and Cox*

# UNITED STATES PATENT OFFICE.

CYRUS M. CARNAHAN, OF UTICA, PENNSYLVANIA.

## IMPROVEMENT IN CAR-COUPINGS.

Specification forming part of Letters Patent No. 190,418, dated May 8, 1877; application filed April 2, 1877.

### *To all whom it may concern:*

Be it known that I, CYRUS M. CARNAHAN, of Utica, in the county of Venango and State of Pennsylvania, have invented a new and useful Improvement in Car-Couplers, of which the following is a specification, reference being had to the accompanying drawings.

The invention relates to an improvement in car-couplers, and consists in the devices hereinafter specifically described, the object being to provide a suitable automatic means of connecting cars.

The figure shown represents a perspective view of a device embodying the elements of the invention.

In the accompanying drawings, A represents the buffer, which has its upper portion immediately above the central recess cut away for a portion of its length, forming the slot B, to receive the jack D, the rear end of which is beveled from front to rear, corresponding with bevel on the rear of the slot B, thereby preventing the jack from losing its position, and insuring a proper operation of the device. Upon one side of the slot B the buffer is provided with the triangular shaped alcove E, in which the bell-crank lever F moves, the arm G of which extends rearward in the curved recess H, which protects it, and the arm I protruding upward and being furnished with the means of freeing the connecting-link from the coupler.

The angle of the bell-crank is pivoted to the side of the jack D at a point to be governed by the size of the couplers.

The forward end of the jack is mounted in the upper front portion of the buffer on the pin L, and has a hinged movement thereon.

The central recess of the coupler is rounded at the buffer end and gradually tapers to a point opposite the rear of the jack D, where it contracts into a square and continues to taper rearward a suitable distance to allow the connecting-link M ample space to operate. It is evident that, as the lower surface of the connecting-link is slightly concave, this form of recess will permit it to gravitate and replace itself beneath the jack when uncoupled,

and that when cars are being connected the link will enter the recess and be compelled to pass rearward beneath the jack. At the same time the link has room to adjust its movement with that of the car, but is prevented from turning and becoming uncoupled.

The connecting-link may be of any convenient form, but preferably it is rounded on the lower surface, and reduced to a squared point at either end, the shoulders N being formed at suitable points near its extremities.

In the operation of the device the shoulders N pass beyond the rear end of the jacks, which automatically fall upon the link in front of them, and thereby prevent its withdrawal.

To the arm I of the bell-crank is fastened one end of the rope P, the other end of which extends upward, and may be secured to any convenient and proper means attached to the car for retaining the jacks D in an elevated position, or dropping them and coupling the cars when desired.

It is obvious that by drawing the rope or chain P upward the jack is elevated, when the link can be withdrawn, and when the tension of the same is loosened the jack is lowered, securing the link, the whole lower surface of the arm G of the bell-crank lever acting as a bearing for the jacks.

What I claim as my invention, and desire to secure by Letters Patent, is—

1. In a car-coupler, the bell-crank F, in combination with the jack D, substantially as set forth.

2. A car-coupler provided with the slot B, oscillating jack D, and bell-crank F, having arms G I, substantially as expressed.

3. The combination of the jack D, bell-crank lever F, and connecting-link M, substantially as specified.

In testimony that I claim the foregoing improvement in car-couplers, as above described, I have hereunto set my hand this 7th day of March, 1877.

CYRUS M. CARNAHAN.

Witnesses:

ISAAC R. STEWART,  
J. F. McIVISTOON.