

P. C. DAWSON.

TRUMPETS FOR RAILWAY HEADS AND DRAWING FRAMES.

No. 190,422.

Patented May 8, 1877.

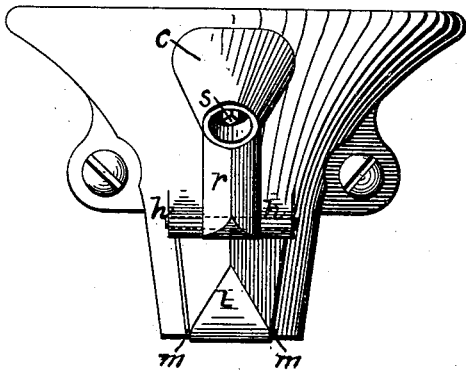

FIG. 1.

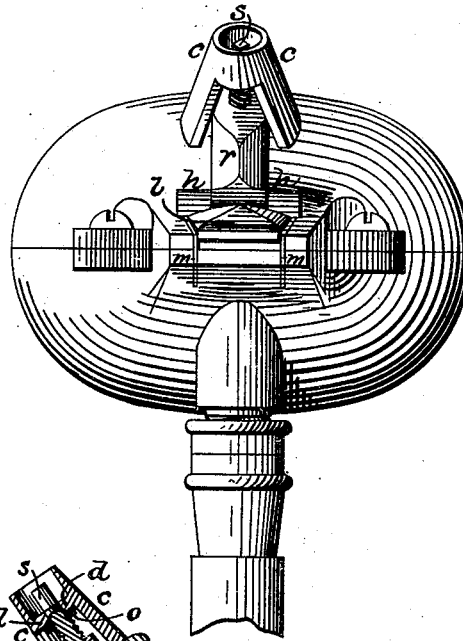

FIG. 2.

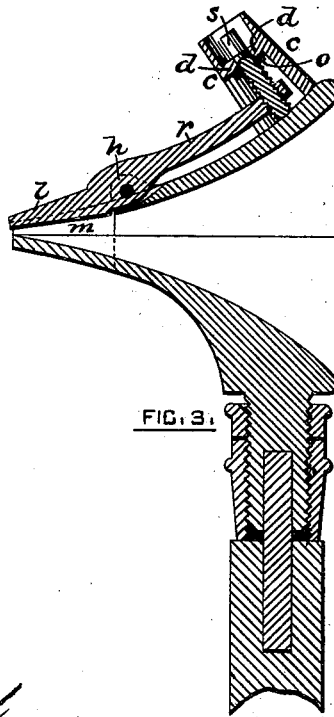

FIG. 3.

WITNESSES.

J. E. Rockwood
Edson S. Jones

INVENTOR.

Patrick C. Dawson
By his Attorney
O. Lapham

UNITED STATES PATENT OFFICE

PATRICK C. DAWSON, OF PROVIDENCE, RHODE ISLAND.

IMPROVEMENT IN TRUMPETS FOR RAILWAY-HEADS AND DRAWING-FRAMES.

Specification forming part of Letters Patent No. **190,422**, dated May 8, 1877; application filed March 2, 1877.

To all whom it may concern:

Be it known that I, PATRICK C. DAWSON, of the city and county of Providence and State of Rhode Island, have invented certain Improvements in Trumpets for Railway-Heads and Drawing-Frames, of which the following is a specification:

It is well known that the rapid passage of the sliver of cotton through the trumpet on railway-heads and drawing-frames wears away the nozzle of the trumpet, so as to render the substitution of a new trumpet necessary, while all the other parts of the trumpet are uninjured, and also that great nicety is required in adjusting a new trumpet to the size of the sliver that is to pass through it, repeated filing away of the inside of the nozzle often being necessary; and, still further, after the nozzle has been properly adjusted to the sliver, and the desired amount of friction obtained, changes in the atmosphere materially disturb this amount of friction, and render some convenient means of regulating the friction or tension in the trumpet very desirable.

The object of my invention is to make the nozzle of the trumpet adjustable, and enable the operator to increase or diminish its interior capacity at will.

In the accompanying drawings, Figure 1 is a top view of my improved trumpet. Fig. 2 is a front view of the same. Fig. 3 is a vertical central section.

The trumpet is cast, as usual, in two parts—upper and lower—which are riveted or otherwise fastened together. The upper half, however, instead of being cast in one piece, is provided with a lip or leaf, *l*, which forms the upper side of the nozzle. This lip is hinged at *h*, and is provided with a lever, *r*, extending toward the top of the trumpet. The lever is operated by means of a screw, *s*, which passes through the end of the lever, and is so confined that by turning it to the right or left it raises or lowers this end of the lever, and closes or opens the nozzle of the trumpet, and at the same time holds the lip firmly in whatever position may be given it. Various methods of operating a lever in this manner and of holding it in position are too well known to require description; but to prevent meddling with the adjustment I prefer to so arrange this part

of the construction that the screw cannot be easily changed except by a key which may be kept in the hands of the proper person in charge of the machine. For this purpose I cast a cap, *c*, which is fastened to the trumpet in the position shown in the drawing, and which covers the screw and the end of the lever, leaving an opening or slot in one side to allow the lever sufficient motion, and with an opening in the top for the insertion of the key. The foot of the screw may rest and turn on the side of the trumpet, and for a bearing in the opposite direction it may be provided with a collar, *o*, bearing against a corresponding shoulder, *d*, on the inside of the cap *c*.

It is important that the lip *l* should form close-fitting joints in whatever working position it occupied, whether more or less open, as the cotton is closely packed or confined in the nozzle as it passes through, and the tendency is to force itself into crevices and apertures and become entangled, and thus clog the trumpet.

In order to secure a more exact fit at the sides of the lip after the latter is set into the trumpet, I make a vertical cut with a saw through the upper and lower halves of the nozzle, and on each side of the lip *l*, and parallel therewith, cutting the side of the lip at the same time. This incision is carried up as far as the lip extends. Into this slot, the sides of which are exactly parallel, I drive a piece of steel or other metal, *m*, exactly filling the slot. This secures a closer-fitting joint than could be obtained by filing the adjacent sides, the pieces of metal so inserted covering the joint between the upper and lower halves of the trumpet.

It is obvious that casting the upper and lower halves of the trumpet together as one piece would be equally within my invention.

I do not, broadly, claim a trumpet so made that the size of the orifice of its nozzle can be varied at will; but

What I claim, and desire to secure by Letters Patent, is—

1. A trumpet for railway-heads and drawing-frames, provided with a hinged or pivoted lip, arranged and adapted to vibrate upon its hinge or pivot, for the purpose of varying the size of the orifice of the nozzle, as set forth.

2. The combination, substantially as set forth, with the main portion of the trumpet, of a hinged or pivoted vibratory lip, forming part of the nozzle, and means, substantially as described, for vibrating said lip on its hinge or pivot, and maintaining it in the desired position of adjustment.

3. The combination, substantially as set forth, with the main portion of the trumpet, of the hinged and vibratory lip, the lever or arm *r*, and the adjusting-screw *s*.

4. The combination, substantially as set forth, of the main portion of the trumpet, the hinged vibratory lip *l*, the lever or arm *r*, the adjusting-screw *s*, and the cap *c*.

5. A trumpet for railway-heads and drawing-frames, in which the sides of the gateway of the nozzle are provided with metallic plates *m*, set into an incision for the purpose of making a close joint, substantially as described, said plates working in connection with the lip *l*, substantially as set forth, and for the purpose specified.

PATRICK C. DAWSON.

Witnesses:

FRANK E. ROCKWOOD,
CHAS. F. PIERCE.