

W. BUCHANAN.

SWITCH SIGNALING APPARATUS.

No. 190,465.

Patented May 8, 1877.

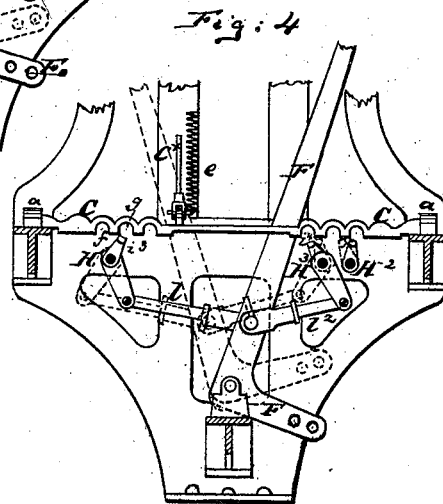
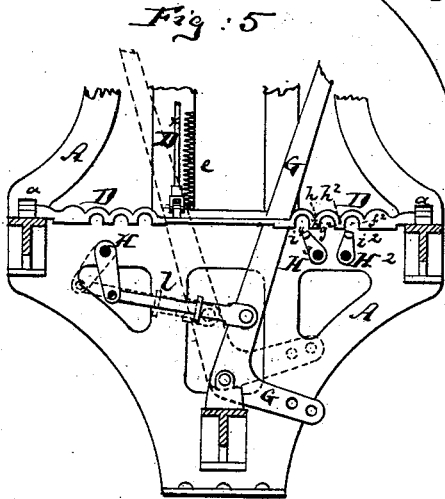
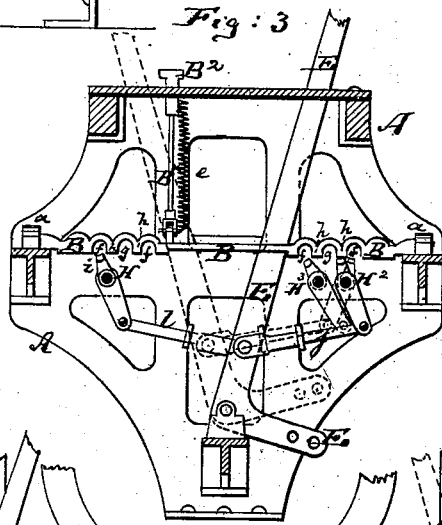
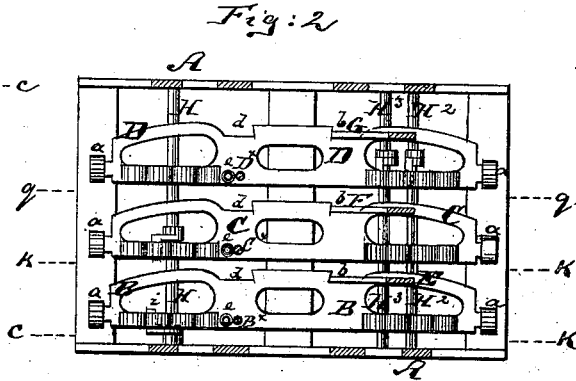
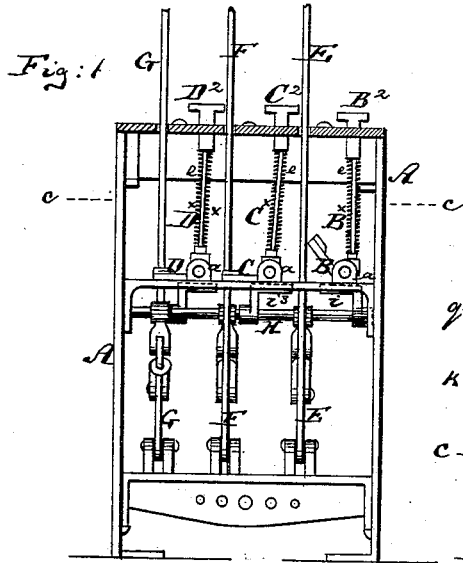

Witnesses:
John C. Tunbridge
A. Briesen

Inventor:
Wm. Buchanan
by his attorney
A. Briesen

UNITED STATES PATENT OFFICE.

WILLIAM BUCHANAN, OF YONKERS, NEW YORK.

IMPROVEMENT IN SWITCH-SIGNALING APPARATUS.

Specification forming part of Letters Patent No. **190,465**, dated May 8, 1877; application filed March 7, 1877.

To all whom it may concern:

Be it known that I, WILLIAM BUCHANAN, of Yonkers, in the county of Westchester and State of New York, have invented a new and Improved Switch-Signaling Apparatus, of which the following is a specification:

Figure 1 is a front view, partly in section, of my improved switch-signaling apparatus. Fig. 2 is a horizontal section of the same on the line *c c*, Fig. 1. Figs. 3, 4, and 5 are longitudinal vertical sections of the same, taken respectively on the planes of the lines *c k*, *k k*, and *g g*, Fig. 2.

Similar letters of reference indicate corresponding parts in all the figures.

This invention relates to a new apparatus for operating railroad signals and switches, and is intended as an improvement on the mechanism described in Letters Patent No. 164,612, dated June 15, 1875.

The present invention consists more particularly in the use of rocking-bars which contain a series of notches on their lower sides, and in their combination with rock-shafts having projecting toes to fit these notches, in manner more fully described in the following specification.

The several notches in each of said rocking-bars are so spaced that the solid portions between them will serve as downwardly-projecting stops whenever they are in line with a toe on a rock-shaft, the rock-shafts being oscillated by the motion of the notch or signal levers. Said levers, in rocking the said shafts, carry the several toes into such position with reference to the notches in the rocking-bars that such of the bars as are to be liberated will have their notches over toes on the rock-shafts, while all the other bars will be locked by the downwardly-projecting stops, as already stated.

The invention also consists in other features of improvement hereinafter more fully pointed out.

In the accompanying drawing I have represented in a suitable supporting-frame, A, three rocking-bars, marked B C D, although a larger or smaller number may be used, two being sufficient for any single switch and signal.

These rocking-bars are, by projecting gud-

geons which are formed at their ends, hung in suitable eyes *a a*, which project from, or are formed on, the frame A, so that in said eyes said bars may be oscillated. The bars B C D are by rods *B^x C^x D^x* connected with foot pieces or treadles *B² C² D²*, respectively, which foot pieces or treadles are placed to extend within convenient reach of the operator, so that whenever a foot-piece is depressed, providing, always, that the rocking-bar with which it is connected is not locked, the said rocking-bar will be swung on its gudgeons to clear the operating lever, as shown with reference to the rocking-bar B in Fig. 1 of the drawing. To each rocking-bar there is a working-lever, three such levers, E, F, and G, being shown in the drawing, the lever E being placed close to the rocking-bar B, the lever F close to the rocking-bar C, and the lever G close to the rocking-bar D. Each of said rocking-bars has on its long edge two notches, *b* and *d*. These notches serve to lock the lever with which each rocking-bar is to operate, for in the normal position of each lever, as indicated in Figs. 2, 3, 4, and 5, by full lines, it is partly embraced by the notch *b* of its rocking-bar, so that it cannot be moved on its pivot unless such rocking-bar is first vibrated by the depression of the foot-piece to clear the lever of said notch *b*, in manner indicated with reference to the lever E, in Fig. 1. The several levers shown are, by suitable rods or devices, which are not represented in the drawing, connected with railway-signals or railway-switches in manner desired, so that whenever a lever is operated—that is, vibrated on its pivot—its appropriate switch or signal will also be moved in the desired manner.

Whenever a lever, E, F, or G, is swung from its normal position into its second position, which is indicated by dotted lines in Figs. 3, 4, and 5, it arrives in the latter position in line with the notch *d* of its rocking-bar, and allows said rocking-bar, which was by the foot-piece placed in an inclined position, to drop back into its proper horizontal position, and lock the said lever by confining it within said notch *d*. To facilitate the proper dropping of the rocking-pieces I apply a spring, *e*, or an equivalent weight, as a connection between each rocking-bar and a suit-

able fixed point in the frame A, so that by such spring or weight the rocking-bar, as soon as the foot-piece is liberated, will at once be thrown back into a horizontal position.

The under side of each rocking-bar B C D has, near one or both of its ends, a series of notches, $f g$ or $f^2 g^2$, with intervening downward-projecting lugs or stops h or h^2 . A rock-shaft, H, having an upwardly-projecting toe, i , i^2 , i^3 , or i^4 , beneath one or more of said rocking-bars, is hung laterally in the frame A, and connected with as many of said levers as it may be desired to connect directly with it. There may be two or more such rock-shafts H on each side of the machine, three being shown in Fig. 3, marked H, H², and H³, respectively, and the larger the number of levers the larger may also be the number of such rock-shafts, and of their notches $f g$ and stops h . Thus the lever E, which is more clearly shown in Fig. 3, is, by a link, j , connected with a crank of the rock-shaft H², which has a toe, i^2 , that works under the rocking-bar D, as shown in Fig. 5. Now, when the lever E is in its normal position the toe i , under its rocking-bar B, is in line with the notch f of said rocking-bar, as in Fig. 3, thus allowing the lever E to be vibrated, for in so vibrating the notched part of the rocking-bar is brought down, and as no obstruction is brought against the toe i , the oscillation of the bar is permitted. When the lever E has been thus liberated from the notch b of its rocking-bar B, and is swung into the dotted position shown in Fig. 3, it oscillates, by its connection j , the shaft H², and carries the toe i^2 , which was on said shaft, into line with the notch f^2 of the bar D, and away from under the stop h^2 of the rocking-bar D, thus liberating said rocking-bar D, and allowing it to be next oscillated; but while the lever E was in its normal position the toe i^2 of the shaft H² was beneath the stop h^2 of the shaft D, as indicated by dotted lines in Fig. 4, and the vibration of the lever was not permitted. Now, the motion of the said rock-shaft H² with reference to its toe i^2 is such that the said toe i^2 is not cleared from the stop h^2 of the rocking-bar D until at the very moment that the lever E is locked into the notch d of the rocking-bar B, so that thus I hold the lever G properly locked, and prevent the motion of the switch or signal with which it is connected until after the lever E has completed its motion entirely. The lever G connects, by a link, l , with the rock-shaft H, and serves, as soon as moved, to carry the toe i of said rock-shaft H under the stop h of the bar B, and thereby prevents said rocking-bar B from being vibrated, and the lever E from being moved back into its normal position. In other words, the lever G cannot be moved into its dotted position until after the lever E is moved into its dotted position, and when the lever G is brought into its dotted position, the lever E cannot be moved back into its normal posi-

tion, being locked by said toe i . Thus one lever always locks and secures the other. This enables me to properly secure switches and signals with reference to one another—as, for example, if the lever E be connected with the signal and the lever G with the body of a switch, I shall be unable to move the switch until after the signal has been brought into a position to indicate danger, which is the dotted position of the lever E, and then after I shall have moved the switch into the dotted position of the lever G, I shall be unable to move the signal back into the safety position until after the switch is again brought back into the safety position.

Now, in connecting these devices with other switches, the same system will be followed. Thus, for example, the rocking-bar C of the lever F will be liberated by the same action of the lever G which locked the bar B, for the rock-shaft H carries a second toe, i^3 , (see Fig. 4,) which is brought under the notch g of the rocking-bar C, as in Fig. 4, at the same time that the toe i is brought under the stop h of the bar B, and the rocking-bar C, being thus liberated, may be oscillated on its gudgeons to liberate also its lever F, and allow the same to be used. The lever F again connects by a link, l^2 , with a third rock-shaft, H³, which has a toe, i^4 , that is carried under a stop, h , of the rocking-bar D to lock the same as soon as the lever F is moved, and thus there is always only one lever ready for action, and this one lever liberates another, and when the other is moved the first is locked, &c., all the parts being so arranged as not to be liable to get out of order, but all readily understood in their operation with reference to one another, and entirely reliable in their effect.

An additional advantage of this apparatus may be found in the fact that although it is possible at any one time to depress two of the foot-pieces or treadles simultaneously, that one which pertains to the lever last brought into the dotted position, and also that one pertaining to the lever next to be operated. Yet if, by accident, or with malicious intent, any person should so depress two of the foot-pieces at the same time, it will be impossible to move either one of the levers, as each one by its connection with one of the rock-shafts, which has a toe under one of the oscillated cross-bars, is locked as soon as the said cross-bar is oscillated to embrace the toe in one of the notches f or g on its under side.

The stop i I prefer to make L-shaped, as shown in Fig. 1, so as to facilitate thereby the proper action of the rocking-bars, which could not be properly moved over an inclined stop; i , if the shank of such stop were directly in the way of the notched bar.

It is unnecessary here to state that in rocking each of said bars that part of each rocking-bar which carries the notches $f g$ is brought down, and that part which has the notches $b d$ moved up.

I claim as my invention—

1. The combination of the switch or signal lever with the oscillating bar B, having two or more notches, *f g*, and intervening stop or stops *h*, and with the rock-shaft having the projecting toe or stop *i*, substantially as herein shown and described.

2. The stop *i*, applied to the rock-shaft H, for combination with the notched rocking-bar

B, said stop being made L-shaped, so that its shank is not directly in line with the notched part of the bar B, substantially as specified.

WM. BUCHANAN.

Witnesses:

F. V. BRIESEN,
J. C. TUNBRIDGE.