

W. A. DAWSON.  
SEWING-MACHINE.

No. 190,475.

Patented May 8, 1877.

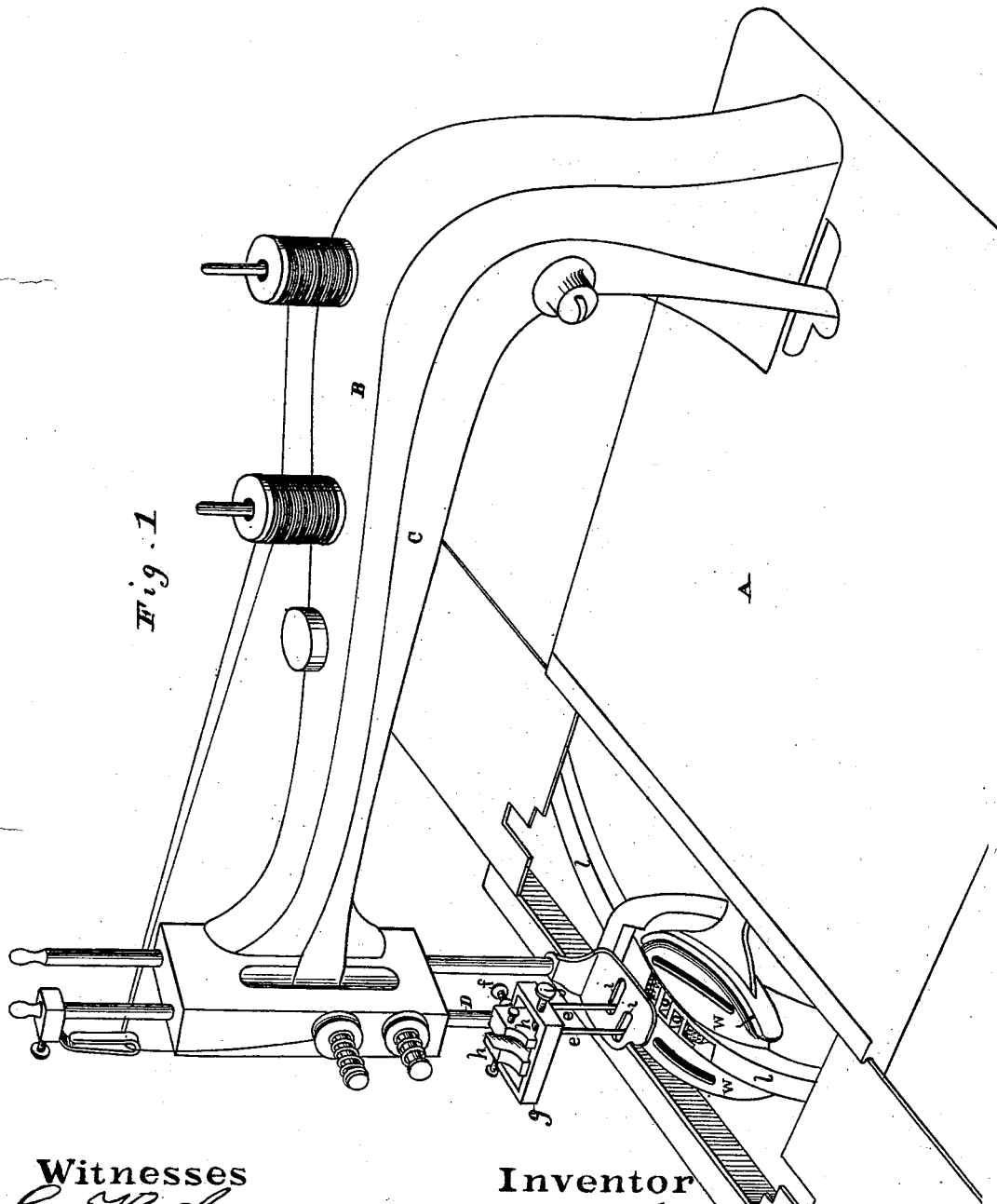

Fig. 1

Witnesses  
*Geo. H. Strong*  
*Olwyn J. Stacy*

Inventor  
*William A. Dawson*  
 By *Dewey & Co.*  
*Atty*

W. A. DAWSON.  
SEWING-MACHINE.

No. 190,475.

Patented May 8, 1877.

Fig. 2

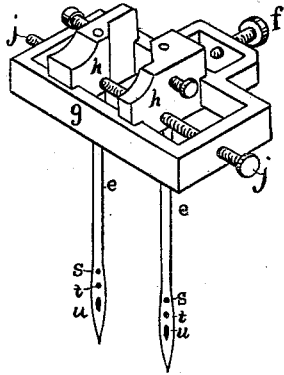

Fig. 3

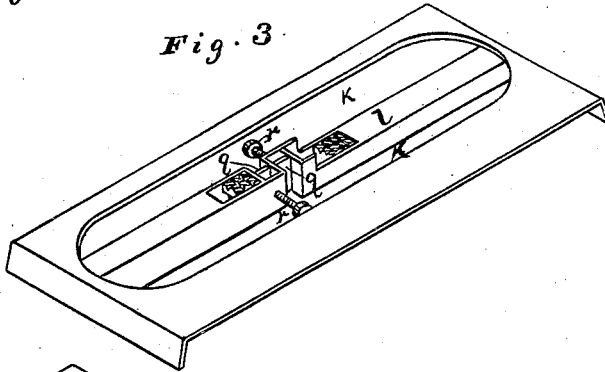
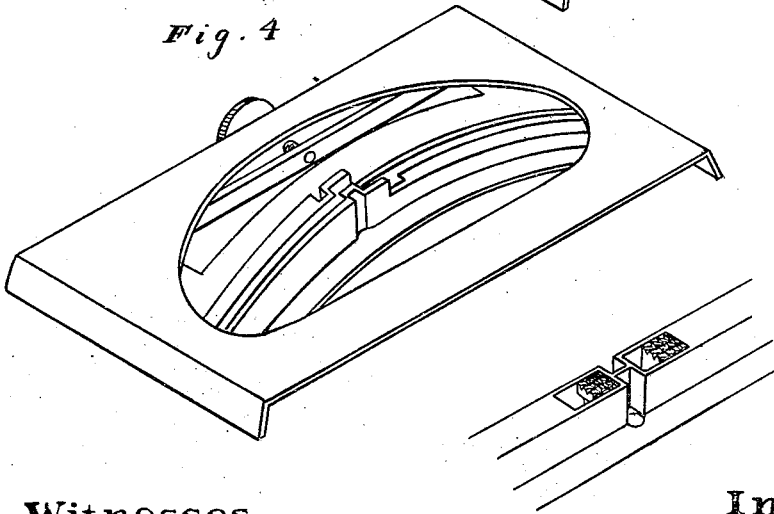

Fig. 4



Witnesses  
*Geo. H. Strong.*  
*Olwyn T. Stacy.*

Inventor  
*William A. Dawson*  
 By *Dewey & Co.*  
*Attys.*

W. A. DAWSON.  
SEWING-MACHINE.

No. 190,475.

Patented May 8, 1877.

Fig. 5.

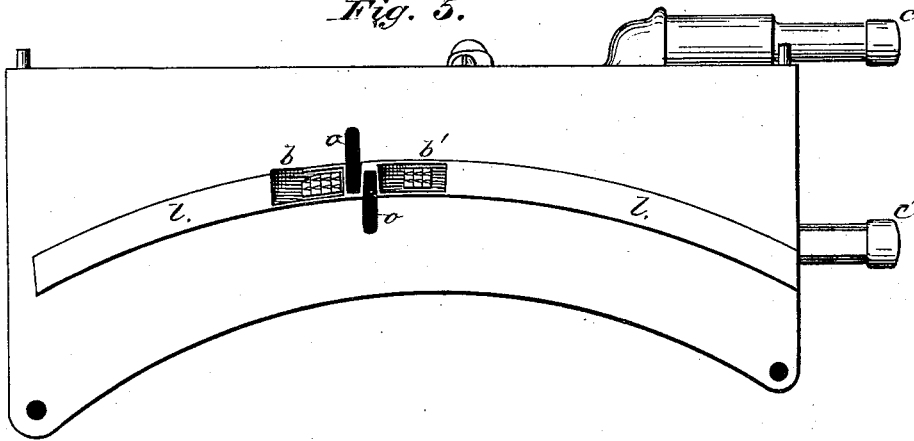

Fig 6.

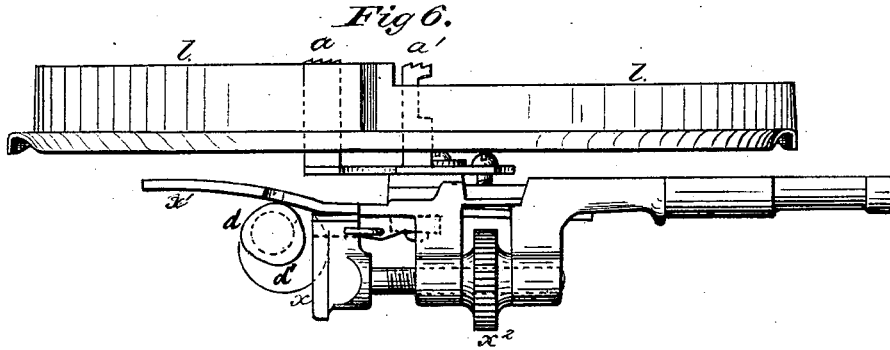
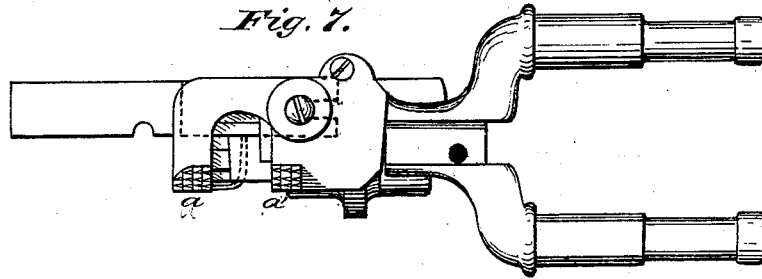

Fig. 7.



Witnesses:

Geo. H. Strong.  
Olwyn J. Stacy

Inventor:

William A. Dawson  
By Dewey & Co  
Attys

# UNITED STATES PATENT OFFICE.

WILLIAM A. DAWSON, OF SAN FRANCISCO, CALIFORNIA, ASSIGNOR OF ONE-HALF HIS RIGHT TO ROBERT D. BURROWS, OF SAME PLACE.

## IMPROVEMENT IN SEWING-MACHINES.

Specification forming part of Letters Patent No. 190,475, dated May 8, 1877; application filed December 19, 1876.

*To all whom it may concern:*

Be it known that I, WILLIAM A. DAWSON, of the city and county of San Francisco and State of California, have invented an Improved Multiple-Seam Sewing-Machine; and I do hereby declare the following description and accompanying drawings are sufficient to enable any person skilled in the art or science to which it most nearly appertains to make and use my said invention without further invention or experiment.

My invention relates to that particular class of sewing-machines in which two or more needles, operated by the same needle-arm, are used for sewing two or more parallel seams.

My invention provides an arrangement for adjusting these needles so that the operator can set them to suit any character or class of work.

Preliminarily I will state that my invention can be applied to any of the double-thread sewing-machines now in use.

In a shuttle machine the shuttle-races can also be made adjustable, corresponding to the adjustment of the needles; but I have discovered that this is not necessary, as I can obtain sufficient width of space for ordinary work by a simple adjustment of the needles and the employment of a looper, which will insure the passage of the shuttles through the loops, even when the needles are set at a distance from them.

Referring to the accompanying drawings, Figure 1 is a perspective view of the machine, with the slides open. Figs. 2, 3, 4, 5, 6, and 7 are detail views.

Let A represent the body of any ordinary sewing-machine. B is the presser-arm, C is the needle-arm, and D is the needle-bar in that class of machines which operate the needles vertically.

Instead of attaching the needles *e e* directly to the lower end of the needle-bar, as has heretofore been done, I attach them to two followers, which are secured in a small frame, *g*, represented at Figs. 1 and 2, and I then attach the frame to the needle-bar. This frame is rectangular in form, and is attached to the needle-bar by a set-screw, *f*, so that it extends out upon one side of the needle-bar, thus ob-

viating any interference with the presser-arm. The followers *h h* are arranged to move like slides inside of this frame, and are shifted to or from each other by a right-and-left hand screw, *j*, so that, by simply turning the screw, the followers can be adjusted as desired.

One of the needles *e* I secure in each of these followers, so that one needle will be slightly in advance of the other.

The holes *i i* in the presser-foot, through which the needles operate, I elongate or slot in opposite directions, allowing their inner ends to overlap, so that the needles can be shifted from a position in which they are both in the same line to the desired distance from each other, and still pass through the needle-holes.

A separate shuttle, *W*, is required for each needle, and, to accommodate these two shuttles, I construct a double race, with an intervening ridge, *l*, between them, so that one shuttle will be on each side of the ridge. On each side of this ridge, near its middle, I make a transverse slot, *o*, beneath each of the holes *i i* in the presser-foot, one of which opens to the race on each side of the ridge, so that the loop of the thread, which is carried by each needle, will buckle through the open end of the slot, and be caught by the passing shuttle in the same manner that the loop is caught by the shuttle in the ordinary single-needle machine. The shuttle-races can be either straight or curved, as desired.

I have discovered that by lengthening the needle, so that its eye will pass low enough below the shuttle-point, I can throw a sufficient loop to engage the shuttle when the needle is set at a considerable distance from it. Originally I constructed two independent shuttle-races, and adjusted them to or from each other by means of screws, to correspond with the position of the needles; but this was found not to be necessary, as I obtain a sufficient result for all practical purposes by lengthening the needles.

In some instances I mount a follower, *q*, (shown at Fig. 3,) in each of the slots *o*, back of the needle, so that it can be moved by means of a screw, *r*, close up against or behind the needle after the needle has been set to the

desired position. This follower serves, by occupying the space behind the needle, to cause the loop to double in an opposite direction, where it will be caught by the shuttle, and it thus insures a positive action to the machine.

Instead of employing the frame *g* for holding the needles, I could employ two needle-bars, and attach one needle to each bar. In this case the bars would have to be made adjustable by means of screws, in a similar manner to that described for the slides of followers.

Each of the needles *e* I provide with three eyes, *s t u*, near the point, one above another, and at a short distance apart. In threading the needles I pass the thread first through the upper eye, then back through the second, and then back again through the third, thus preventing the thread from being cut, as often occurs when a single eye is used; secondly, preventing the thread from slipping through the eye, thus insuring a permanent loop; and, lastly, providing a uniform tension, which aids in making neat work.

The feeding-dog is divided into two parts, *a a'*, and the needles *e e* operate between these parts. These parts *a a'* work within the slots *b b'* in the intervening ridge *l*, and receive a vertical and lateral movement in one direction by means of two cams or eccentrics, *d d'*, upon the driving-shaft, and a return movement in the opposite direction by one or more spiral springs on the rods *c c'*. The cams or eccentrics *d d'* upon the driving-shaft work against the parts *x x'*, and the lateral movement of the feeding-dog is regulated by means of the thumb-screw *x<sup>2</sup>*.

I thus provide an important improvement in this class of sewing-machines by adapting each machine to sew parallel seams at varying distances apart, as desired.

Double-seam stitching is now being quite generally adopted in sewing heavy material, and my improvement is intended to adapt the machines for this work.

Having thus described my invention, what I claim, and desire to secure by Letters Patent, is—

1. The frame attachment *g*, having the slides or followers *h h*, operated by the right-and-left hand screw *j*, in combination with the needles *e e* and needle-bar *D*, substantially as and for the purpose described.

2. The ridge *l*, which separates the shuttle-races *k k*, provided with the opposite slots *o o*, in each of which an adjustable follower, *q*, is arranged to be moved by a screw, in combination with the shuttles *w w*, and adjustable needles *e e*, substantially as and for the purpose described.

3. The combination of the intervening ridge *l*, having the slots *b b*, feeding-dog, divided into two parts, *a a'*, devices *x* and *x'*, cams or eccentrics *d d'* upon the driving-shaft, and thumb-screw *x<sup>2</sup>*, the several parts constructed and arranged to operate in the manner herein shown and described.

In witness whereof I have hereunto set my hand and seal.

WILLIAM A. DAWSON.

Witnesses:

J. L. BOONE,  
F. A. BROOKS.