

H. W. WILSON.  
VAPOR-BURNER.

No. 190,529.

Patented May 8, 1877.

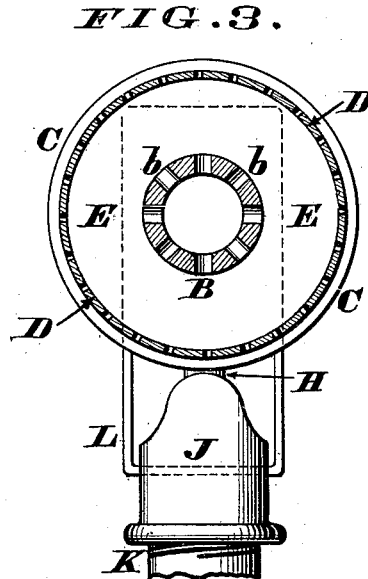
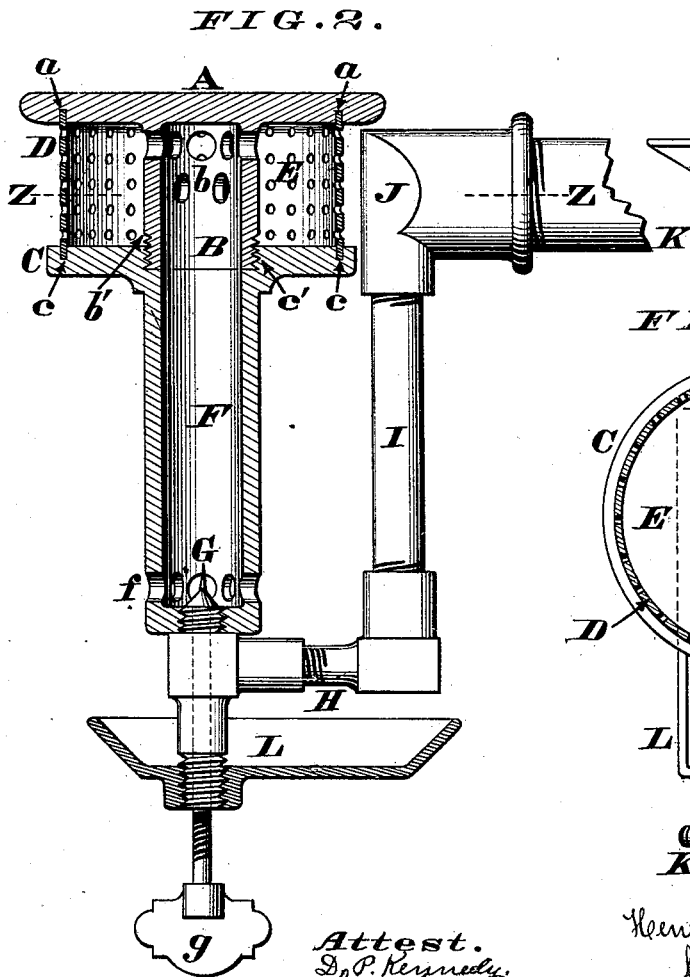
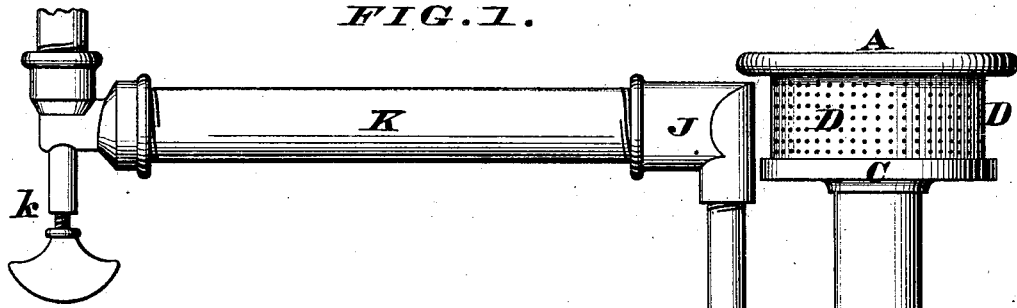

Attest.  
D. P. Kennedy,  
C. W. Layman.

Henry W. Wilson  
by James H. Layman,  
his Attorney.

# UNITED STATES PATENT OFFICE.

HENRY W. WILSON, OF WEST COVINGTON, KENTUCKY.

## IMPROVEMENT IN VAPOR-BURNERS.

Specification forming part of Letters Patent No. 190,529, dated May 8, 1877; application filed April 20, 1877.

*To all whom it may concern:*

Be it known that I, HENRY W. WILSON, of West Covington, Kenton county, Kentucky, have invented certain new and useful Improvements in Gasoline-Burners, of which the following is a specification:

The object of my invention is to furnish a burner for gasoline or other hydrocarbons, in which the fluid will be vaporized in the most complete manner before being ignited; and I accomplish this result in the following way: The burner consists, essentially, of two disks or other suitably-shaped heads or plates, composed of brass or iron, or any other metal capable of resisting an intense heat. These disks or heads are separated a suitable distance, and are maintained parallel with each other by means of a cylindrical disperser, whose margins are fitted in annular grooves in the opposing faces of said heads. This disperser is preferably composed of tin or other thin sheet metal, and is pierced very thoroughly with small perforations, in order that the highly-vaporized gasoline may issue from this perforated cylinder in numerous minute jets, not in a few large currents, as has heretofore been customary. Said disperser constitutes the inclosing walls of an annular chamber, whose central member is a tube cast with or otherwise rigidly depending from the upper head. The upper portion of this tube is perforated or slotted to admit vapor to the annular chamber, while the lower part of said tube has a male thread that engages with a female thread cut in the lower head, the main channel or bore of the tube communicating directly with the chimney of the burner. This chimney is cast with, or otherwise rigidly attached to, the lower head, so as to project downwardly therefrom, and is pierced near its lower end with a series of air-inlets. Furthermore, the lower end of said chimney has applied to it a customary needle-valve, where-with the flow of vapor is regulated in the usual manner. The vapor has access to the orifice of this needle-valve by means of a horizontal inlet, that communicates with a vertical pipe, to whose upper end is coupled an elbow or bend screwed to the gasoline-chamber, which latter receives its supply of hydrocarbon from an elevated tank or reservoir of any suitable

kind. This connecting-elbow is located in close proximity to the disperser, and is completely enveloped in a number of the ignited jets issuing from said disperser, as hereinafter more fully explained.

In the annexed drawing, Figure 1 is an elevation of my burner. Fig. 2 is an enlarged axial section through the operative parts of the same, and Fig. 3 is a horizontal section at the line Z Z.

The upper head A, which is preferably a metallic disk, is provided on its under surface with an annular groove, *a*, for a purpose which will presently appear. Cast with this head, or secured thereto, is a downwardly-projecting tube, B, pierced near its upper end with perforations or slots *b*, and threaded, *b'*, at its lower end, to engage with the female thread *c'* of the other head C. This head is also disk-shaped, and has an annular groove, *c*, of the same size and diameter as the groove *a*, previously alluded to. Adapted to fit snugly within these opposing grooves is the disperser D, consisting of a tin or other sheet-metal cylinder pierced with numerous minute apertures; or, if preferred, a wire-gauze may be substituted for this perforated cylinder.

Cylinder D preserves the heads A and C a suitable distance apart, and when screw *b'* is engaged with couplings *c'*, said disperser is securely clamped within the retaining-grooves *a* and *c*.

Located between tube B and cylinder D is an annular chamber, E, which collects the vapor as it issues from apertures *b* of said tube. Cast with or otherwise rigidly secured to head C is the customary chimney F, whose bore is about equal in diameter to the tube B, with which latter it communicates, and said chimney is provided near its lower end with a series of air-inlets, *f*. Vapor is admitted to this chimney by a needle-valve, G, controlled with a suitable thumb-piece or handle, *g*. H is a horizontal inlet, that conducts vapor to the channel or orifice traversed by needle G. This inlet branch communicates with a vertical pipe, I, to whose upper end is coupled an elbow, J, which elbow or bend is located in close proximity to the disperser D. Engaged with this elbow is the gasoline-chamber K, having a cock, *k*, which admits any desired

quantity of fluid into chamber K from an elevated reservoir. L is a pan, for containing a sufficient quantity of combustible fluid wherewith to start the burner.

The operation of the device is as follows: Pan L is first charged with fluid, and cocks *g* *k* are opened to permit a proper quantity of gasoline to flow through pipes K J I H, after which said fluid is ignited to initiate the vaporizing process, which vapor then issues at the orifice traversed by needle-valve G. As the vapor ascends chimney F, a supply of air is drawn in at openings *f*, and this mingled vapor and air then enters chamber E through apertures *b* of tube B. The vapor now escapes through the numerous apertures in cylinder D, and is thus dispersed or divided into a great number of very minute jets or streams, which instantly ignite and merge into an unbroken sheet of flame surrounding the head A of the burner. A considerable number of these ignited jets envelop the elbow J, which latter soon becomes highly heated, as does also the connections K, I, and H.

By thus heating these various component members of the burner, the hydrocarbon is thoroughly vaporized before it enters chimney F, and, as a result of this complete vaporization, the most perfect combustion takes place as soon as the gas escapes from disperser D and ignites, which combustion of the gas produces no blowing or other disagreeable noise.

This burner can be used in every place where such a device is serviceable; but it has been designed more especially for use with a

summer-stove, or for other domestic purposes. When used with a stove, the burner is inserted in the fire-chamber, and the upper head A is caused to occupy a central position in one of the stove-holes, in order that the ordinary utensils may be employed for cooking or other culinary purposes.

In this specification, where the heads A and C are alluded to as composed of any "metal capable of resisting an intense heat," it is not to be inferred that said heads are non-conductors, as it is desirable they shall communicate as much heat as possible to the various connections of the burner.

I claim as my invention—

1. An improved gasoline-burner, consisting of a perforated disperser, D, clamped between two heads, A a C c, by means of perforated tube B b and couplings *b' c'*, which perforated tube communicates with the chimney F, substantially as herein described, and for the purpose set forth.

2. An improved gasoline-burner, consisting of heads A a C c, pierced tube B b, perforated disperser D, chimney F *f*, and connections H I J K, the elbow or bend J being located in close proximity to said perforated disperser D, substantially as herein described, and for the purpose set forth.

In testimony of which invention I hereunto set my hand.

HENRY W. WILSON.

Witnesses:

JAMES H. LAYMAN,  
D. P. KENNEDY.