

R. CHARTREY.
 WASHING-MACHINE.

No. 190,552.

Patented May 8, 1877.

Fig. 1.

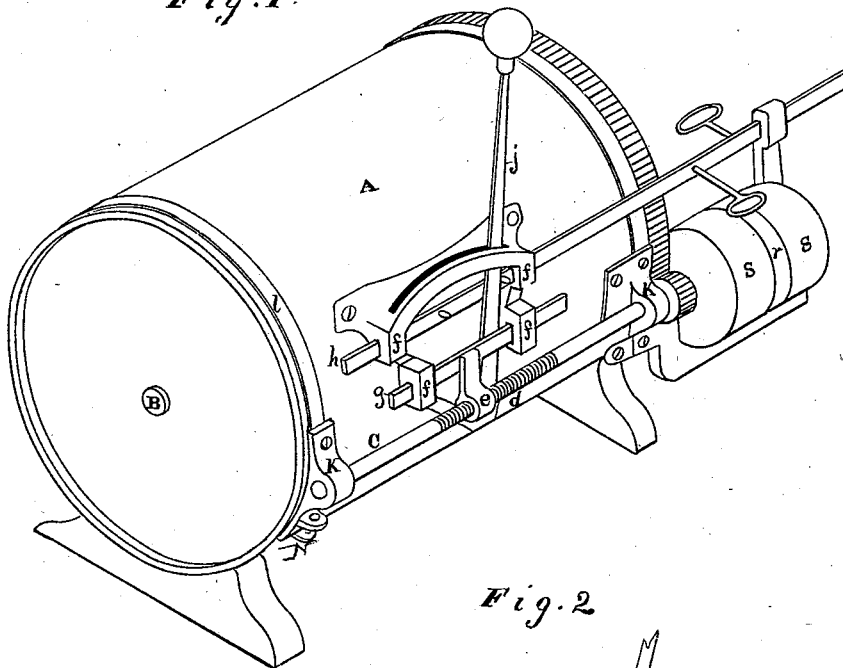
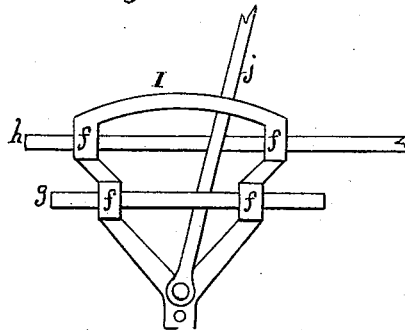

Fig. 2.



Witnesses

Geo. H. Strong
Jas. L. Bonke

Inventor

Raoul Chartrey
 by *Dewey & Co.*
 Attys.

UNITED STATES PATENT OFFICE.

RAOUL CHARTREY, OF SAN FRANCISCO, CALIFORNIA.

IMPROVEMENT IN WASHING-MACHINES.

Specification forming part of Letters Patent No. **190,552**, dated May 8, 1877; application filed January 27, 1877.

To all whom it may concern :

Be it known that I, RAOUL CHARTREY, of the city and county of San Francisco, and State of California, have invented Improvements in Washing-Machines; and I do hereby declare the following to be a full, clear, and exact description thereof, reference being had to the accompanying drawings.

My invention relates to certain improvements in that class of steam-power laundry-machines in which a dasher or dashers are rotated alternately in one direction, and then in another inside of a case, and in which the alternate motion of the dashers is produced by an automatic belt-shifting device, which is attached to the side of the case.

Heretofore the boxes or bearings in which the moving parts of this shifting device were supported were made in separate pieces, and these pieces were attached separately to the side of the case in their proper relative positions with reference to each other. This arrangement was defective, because any shrinking or swelling of the case disarranged the bearings, so that the mechanism would bind and cause trouble. This defect I remedy.

The driving and loose pulleys were also mounted upon a driving-shaft separate from, and independent of, the shaft which operated the belt-shifter. I mount them upon the same shaft, and otherwise simplify and improve the machine, as hereinafter described.

Referring to the accompanying drawings, Figure 1 is a perspective view of my machine. Fig. 2 is a view of the casting.

Let A represent the cylinder or case, inside of which the dashers are mounted upon the central shaft B. C is the supplementary shaft, in the middle of which the short screw-section *d* is found. This screw-section serves to move the traveler or nut *e* of the belt-shifting device.

ffff are the boxes or bearings in which the slides *g h* move, and these boxes, as above mentioned, have heretofore been made in separate pieces, and attached separately to the side of the case.

I, however, make a single frame or casting, I, (represented at Fig. 2,) in which I form, or to which I attach, the boxes or bearings, and to which I also pivot the lower end of the

weighted bar *j*, which moves the slides *g h*. I then secure the casting to the side of the case, so that shrinking or swelling of the case will not affect the relative positions of the bearings.

The boxes K K, in which the shaft C is supported, were heretofore simply attached to the hoops or bands *l*, which bind the ends of the case, by making them form a part of the hoops—that is, a lug (shown at O) was formed on each end of the box, the hoop was cut short enough to admit the box between its ends, and the ends of the hoop were then turned up, and a screw or rivet connected them with the lugs on the box.

By my improvement, however, I make a lug only at one end of the box, as represented, and this lug I attach, in the ordinary manner, to one end of the hoop or band *l*. The hoop then passes around the case, and its opposite end is passed under the opposite end of the box-casting. I then insert a screw, *x*, through the end of the casting, through the end of the hoop, and into the wood of the case, thus not only fastening the end of the hoop, but also securing the box from displacement by securing it firmly to the case.

Heretofore the fixed pulley *r* and loose pulleys *s s* were mounted upon an independent shaft, while the shaft C was only used to operate the belt-shifters.

I, however, extend the shaft C beyond the end of the machine, and mount these pulleys upon the end of the shaft C, and thus render the machine more compact.

Having thus described my invention, what I claim, and desire to secure by Letters Patent, is—

1. The boxes or bearings *ffff*, all attached to a single frame-casting, I, which is secured to the side of the case, and to which the lower end of the weighted bar *j* is also pivoted, substantially as and for the purpose described.

2. The improvement in connecting the boxes K K with the bands or hoops *l*, consisting in attaching one end, N, of each hoop to one end of the casting by means of a lug, O, on said casting, and inserting their opposite ends underneath the opposite ends of the box-casting, and securing the whole by a screw,

x , which passes into the wood underneath, substantially as and for the purpose described.

3. The shaft C, provided with the screw-section d , for operating the automatic belt-shifter, and having the fixed pulley r and loose pulleys $s s$ mounted on its end, substantially as and for the purpose described.

In witness whereof I have hereunto set my hand and seal.

RAOUL CHARTREY. [L. S.]

Witnesses:

GEO. H. STRONG,
FRANK A. BROOKS.