

E. H. JOHNSON.  
PAPER-FEEDING MACHINE.

No. 190,596.

Patented May 8, 1877.

Fig. 2.

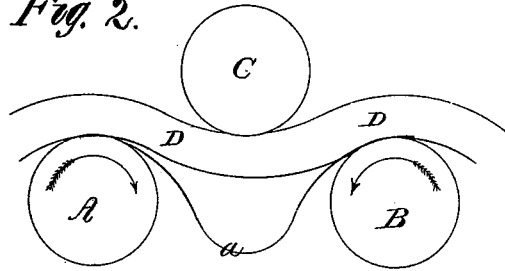

Fig. 1.

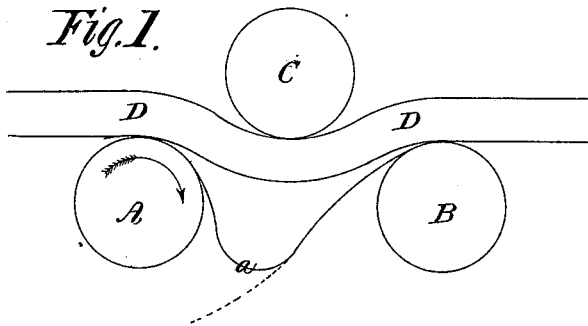
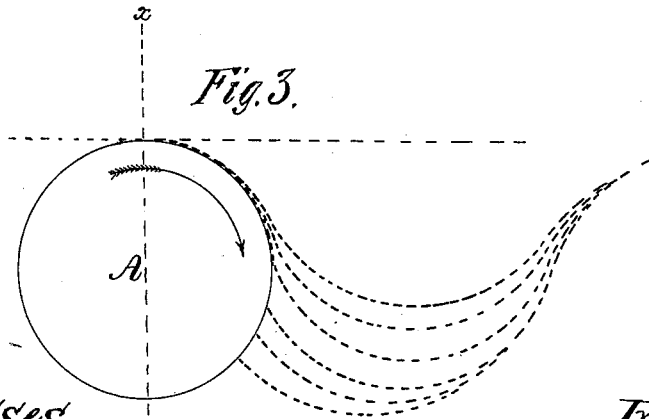

Fig. 3.



Witnesses.

Alpertheok.

Sam<sup>r</sup> Brown.

Inventor

Edward H. Johnson.

E. H. JOHNSON.  
PAPER-FEEDING MACHINE.

No. 190,596.

Patented May 8, 1877.

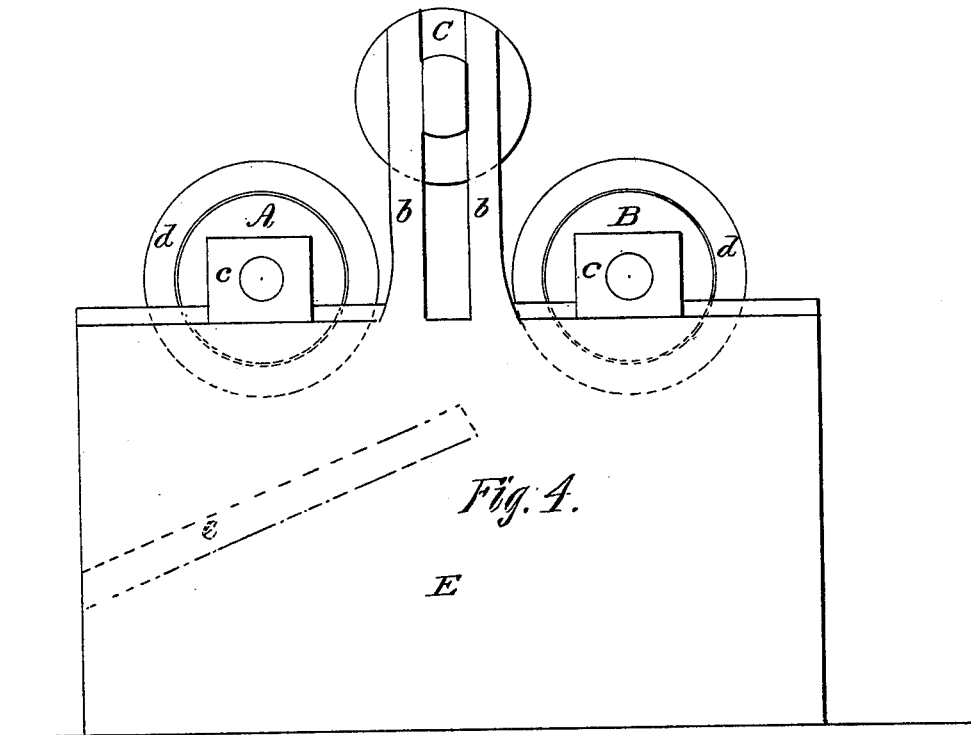

Fig. 4.

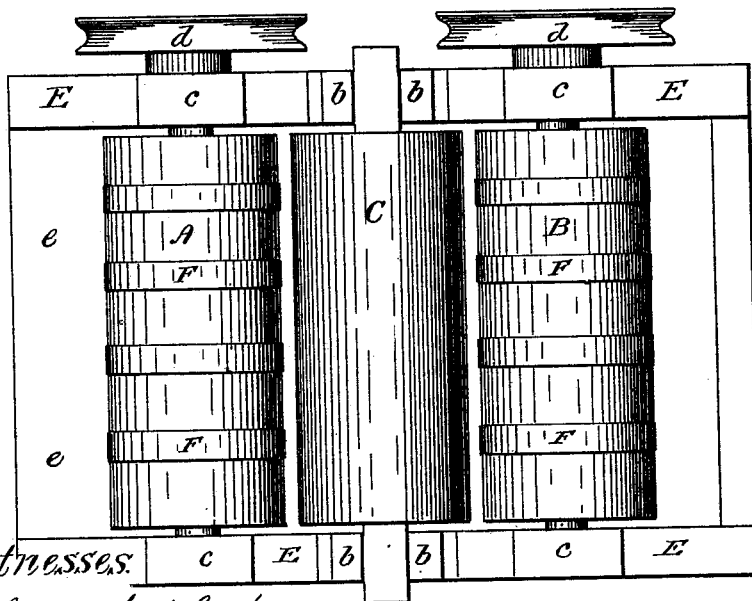

Fig. 5.

Inventor  
Edward H. Johnson.

Witnesses:  
Alfred Hedlock.  
Saml. Brown.

# UNITED STATES PATENT OFFICE

EDWARD H. JOHNSON, OF BROOKLYN, ASSIGNOR OF ONE-HALF HIS RIGHT  
TO GRIFFITH & BYRNE, OF NEW YORK, N. Y.

## IMPROVEMENT IN PAPER-FEEDING MACHINES.

Specification forming part of Letters Patent No. **190,596**, dated May 8, 1877; application filed  
December 13, 1876.

*To all whom it may concern:*

Be it known that I, EDWARD H. JOHNSON, of Brooklyn, county of Kings, and State of New York, have invented certain Improvements in Paper-Feeding Machines, of which the following is a specification:

My invention relates to devices for feeding sheets of paper to printing-presses and other machines; and consists in a frictional roller, which acts on the pile of sheets, which is held at a point behind the roller, so as to draw or push back the sheet against which it acts, and carry the edge of such sheet around on its periphery until, by the elasticity of the sheet, it springs forward on the other side of the roller, and is thus presented to the nippers or other devices for carrying it off. It consists, further, in a combination with such frictional roller of other parts, as will be fully hereafter described.

Figures 1, 2, and 3 are diagrams illustrating the principle of operation of my invention. Fig. 4 is a side elevation of the feeder, and Fig. 5 a top or plan view.

In Fig. 1 are shown two parallel horizontal rollers, A and B, one of which, B, is stationary. Immediately above and midway between these rollers, and parallel therewith, is a roll or bar, C, stationary as regards rotation, but capable of a vertical motion. The pile of sheets of paper represented at D is shown as supported on the rollers A and B, and slightly pressed down between them by the roll or bar C. On revolving the roller A in the direction indicated by the arrow thereon, the bottom sheet of the pile will be drawn inward, and the sheet will be bellied between the roller A and the roller B, which acts as a support and stop for the rear end of the pile. Thus one end of the sheet is delivered to the nippers of the press, while the other extremity is held between the superincumbent sheets and the roll B, and is drawn therefrom by the nippers; or the roller B may be rotated to carry or help the sheet forward after the front edge has been released.

In Fig. 2 are also shown two rollers, A B; but in this diagram both rollers are shown as revolving in opposite directions, as indicated by the arrows thereon. In this instance, there-

fore, if the rollers be simultaneously revolved at equal speed, both extremities of the bottom sheet will be bellied between the rollers, as shown at *a*, Fig. 1, and eventually entirely passed between the rollers, both ends being set free simultaneously.

At Fig. 3 is shown the manner in which the edge of the paper is carried around the periphery of the roller. The series of broken lines indicate the different positions of the sheet. As the roller revolves, the sheet is bellied downward, and thus wrapped partly around the roller, so that when the edge arrives at the center line of the roller (*xx*) it (the edge) is carried around by the friction on the portion of the sheet wrapped around the roller.

In Fig. 4, E is the side frames; A B, the feeding-rollers, one or both of which may revolve. C is the pressure-roll, moving vertically in the uprights *b b*, the pressure of which roll on the paper may be governed by springs or other means. The thinner the sheet the less the pressure required to be exerted on the pile, and with some paper I have found that the pressure-roll may be dispensed with, the weight of the paper being sufficient to create the requisite friction between the bottom sheet and the feeding-roller. The rollers A B have bearings in the boxes *c c*, which may be made to slide along the side frame, as shown, so that the distance apart of the rollers A B may be regulated. *d d* are pulleys secured to the shafts of the rollers A B, by means of which and a cross-belt they may be driven together. These pulleys, however, may be replaced by gearing for driving the rollers continuously or intermittently. *e e* represent the table on which the sheets are delivered to the mechanism of the press. The rollers A B are provided with frictional bands F F.

I claim—

1. In a paper-feeding machine, the roller A, applied beneath the pile of sheets, substantially as described, and so operating thereon as to draw or push back the edge of the sheet against which it acts, and pass the edge around its periphery until, by the elasticity of the sheet, it springs forward on the side of

the roller opposite the side on which it acts on the pile of sheets, substantially in the manner described and specified.

2. The combination, with the friction-roller A, of the pressure-bar C, for depressing the pile of sheets at a point behind the roller A, whereby the surface of contact between the roller and the sheet is increased, substantially in the manner described and specified.

3. In a paper-feeding machine, the combination of the rollers A and B, applied beneath the pile of sheets, substantially as described, and so operating as to draw the two extremities of the sheet against which they act together, without breaking the sheet, and pass

its edges around their peripheries until, by the elasticity of the sheet, the ends spring apart, and the sheet thus freed on the side of the rollers opposite the side on which they act on the pile, substantially in the manner described and specified.

4. In combination with the friction-rollers A and B, the pressure-bar C, for depressing the sheets between said rollers, substantially in the manner described and specified.

EDWARD H. JOHNSON.

Witnesses:

DANIEL BROWN,  
ALFRED SHEDLOCK.