

W. GILLILAND.  
BINDING BOOKS.

No. 190,677.

Patented May 15, 1877.

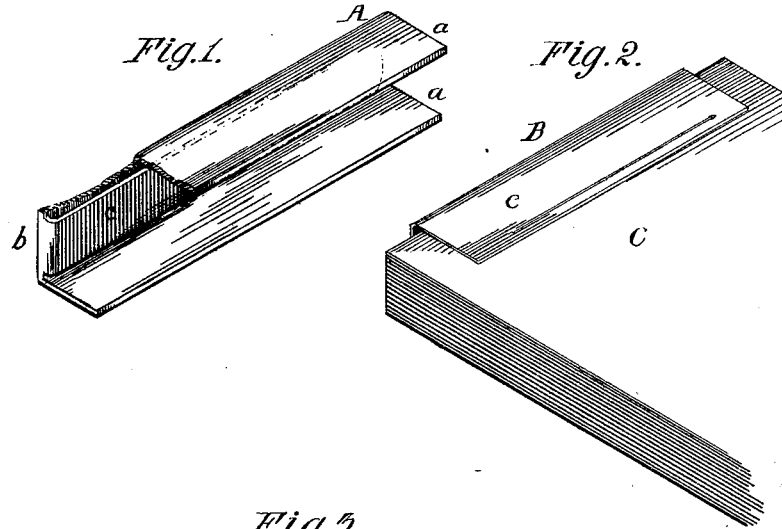

Fig. 5.

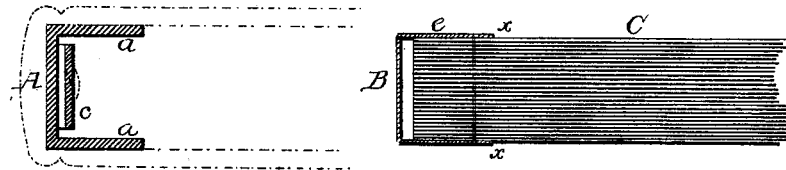
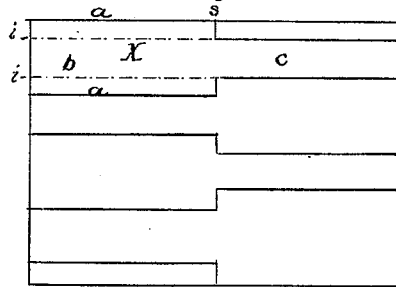

Fig. 4.



Attest:

*Fred Benjamin*  
*Howard Zuehl*

Inventor:

*W. Gilliland*  
*By his attorney*  
*Charles Porter*

# UNITED STATES PATENT OFFICE.

WILLIAM GILLILAND, OF NEW BRIGHTON, PENNSYLVANIA.

## IMPROVEMENT IN BINDING BOOKS.

Specification forming part of Letters Patent No. **190,677**, dated May 15, 1877; application filed April 21, 1877.

*To all whom it may concern:*

Be it known that I, WILLIAM GILLILAND, of New Brighton, Beaver county, Pennsylvania, have invented new and useful Improvements in Binders, of which the following is the specification:

The object of my invention is a binder, constructed as fully described hereafter, so as to securely retain packages of blanks, as checks, orders, prescriptions, &c., together within permanent covers without interfering with the ready removal of either single blanks, or of the whole package, or of the stubs after the blanks have been torn therefrom.

In the accompanying drawing, Figure 1 is a perspective view, partly in section, showing that part of the binder which is attached to the cover; Fig. 2, a similar view, showing a package of blanks and the portion of the binder which is secured thereto. Fig. 3 is an enlarged sectional view; and Fig. 4, a plan view, showing the mode of making the metallic portion of the binder.

The binder consists of the metallic retainer A, which is attached to the cover, and the pocket B, formed in any suitable manner upon the package C of check-blanks, orders, &c., which it is desired to protect by a cover.

The retainer A is of metal, having flanges *a a*, parallel to each other, extending from a back-piece, *b*, and a tongue, extending along the inner side of the back-piece, and secured thereto at one end.

The pocket B is formed by folding a strip, *e*, of fabric, leather, thin metal, or other material over the edge of the package C and stitching it, or otherwise securing it thereto at the edges, as shown in Figs. 2 and 3.

The retainer A is secured in any suitable manner within the cover of the book. The packet of leaves C, with the pocket B, is then introduced into the end of the retainer, and is pushed along the latter, so that the tongue *c* shall enter the pocket B until the retainer is midway between the edges of the leaves, which are thereby securely confined, so that they cannot be displaced by any change in the position of the book, unless it be held with the

end of the tongue downward in an absolutely vertical position. While thus secured the separate leaves may be detached in the ordinary manner, the edge *x* of one of the flanges *a* serving as a cutter in tearing them off; and after all have been removed, or it becomes necessary to substitute others therefor, the stub or partial package may be readily detached by sliding it from the retainer in the direction of the end of the tongue.

It will be apparent that the tongue *c* serves to securely retain the packet, regardless of the thickness of the latter, and that the flanges of the retainer do not act, as in other retainers, as clamps to secure the leaves.

If necessary, the tongue may be stiffened in any suitable manner; and it may be curved or bent, to more effectually secure the package; and a series of loops may be substituted for the strip *e*, to form a pocket.

It will further be seen, on reference to Fig. 4, that the retainers may be readily manufactured, with but little waste of the metal, from a sheet, by cutting therefrom blanks X, of the shape shown, the narrower portion of the blanks, when folded on the line *s*, forming the tongues *c*, and the wider portions, when folded on the lines *i*, forming the back *b* and flanges *a*.

I claim—

1. The combination, in a binder, of a retainer, A, having flanges *a* and an internal tongue, *c*, and a pocket, B, formed upon a packet, C, of the papers to be secured, all substantially as set forth.

2. The packet C with its pocket B, adapted for attachment to a tongue, *c*, of a retainer attached to the cover, substantially as specified.

3. The retainer, carrying a tongue, *c*, arranged to be parallel with the back of the book, and adapted to be inserted in a pocket on the packet of leaves, as specified.

In testimony whereof I have signed my name to this specification in the presence of two subscribing witnesses.

WILLIAM GILLILAND.

Witnesses:

BENJ. WILDE,  
C. M. MERRICK.